

# PARTS LEGEND

MODEL 5400/100S-WB-Q, 500211

Δ1	013625	7	Socket Head Capscrew, #8-32 x 1/2"	52	402401	1	Lever
2	401955	6	Flat Washer, #8	53	402396	2	Bushing, Lever
**3	402448	1	Air Diffuser	Δ54	401940	1	End Plug
4	402447	4	Spacer	55	091622	1	Reducing Pipe Bushing
7	500079	4	Socket Head Capscrew, 1/4-20 x 5"	56	401997	1	Cup, Knob
8	002187	4	Lock Washer, 1/4"	57	401996	1	Spring, Knob
9	091447	4	Flat Washer	58	401993	1	Knob
10	500071	1	Cap	59	401998	1	Mounting Insert
*11	401983	1	Gasket	*60	402008	1	Gasket, Nose Flange
12	401943	1	Conical Spring	61	402005	1	Flange, Nose
13	401953	1	Retaining Ring	62	006787	2	Roll Pin, 3/16" Dia. x 1" Lg.
*14	401952	1	"O" Ring, Upper Valve Piston	63	401988	1	Spring, Work Contacting Element
15	401947	1	Upper Valve Piston	64	402014	1	Work Contacting Element
16	401946	1	Seal, Main Valve	65	402094	2	Flat Washer, #10
*17	401951	1	"O" Ring, Lower Valve Piston	66	004238	1	Lock Washer, #10
*18	091208	1	"O" Ring, Lower Valve Piston	Δ67	009037	2	Socket Head Capscrew, 10/32 x 1/2"
*19	401950	1	"O" Ring, Lower Valve Piston	68	401990	1	Work Contacting Element (5350)
20	401948	1	Lower Valve Piston	69	402095	1	Nut Bar
21	401949	1	Post	70	401907	1	Nose (5350)
22	095432	1	"O" Ring, Post	71	009016	4	Socket Head Capscrew, 5/16-18 x 1"
Δ23	402906	1	Button Head Capscrew, #10-32 x 5/8"	72	095417	4	Lock Washer, 5/16"
25	091861	1	Nut	73	002442	6	Lock Washer, #8
26	092116	1	Washer	74	401979	1	Cover, Magazine
*27	091863	1	"O" Ring, Piston	75	401978	1	Spring, Upper Work Contacting Element
28	500077	1	Piston	76	401977	1	Upper Work Contacting Element
29	401905	1	Driver Blade	77	402010	2	Bushing
30	500078	1	Seal, Sleeve	78	091363	3	Flexloc Thin Nut #8-32
31	500076	1	Sleeve	79	403733	1	Magazine, Right and Left
*32	092762	1	"O" Ring, Sleeve	81	401921	1	Shear Block (including Pin), Right
*33	091024	1	"O" Ring, Sleeve	82	401975	2	Pin, Shear Block
34	401984	1	Flange	83	401966	1	Follower Assembly
34A	402993	1	Shim	85	404661	1	Shear Block (Including Pin), Left
35	401985	1	"O" Ring, Flange	86	401965	1	Drum, Negator
*36	404917	1	Bumper	*87	401964	1	Spring, Negator
37	401936	1	Housing	88	403042	1	Cover, Spring
38	401939	2	Logo, Housing	89	008731	1	Socket Head Capscrew, #10-24 x 3/4"
39	097748	1	Spring, Valve Pin	90	404045	1	Socket Head Capscrew, #8-32 x 1-1/8"
40	097746	1	Valve Pin	91	403738	1	Pin, Magazine
*41	092174	1	"O" Ring, Valve Body	92	403739	1	Spring, Magazine Pin
42	401958	1	Valve Body	93	023766	1	Retainer Ring
43	025133	3	Roll Pin, 1/8" Dia. x 1" Lg.	94	090971	1	Socket Head Capscrew, #8-32 x 7/8"
44	401992	1	Spring, Intermediate Work Contacting Element	95	401961	1	Channel
45	401991	1	Intermediate Work Contacting Element	97	403740	1	Spacer, Magazine
46	096893	1	Nameplate	98	091591	1	"O" Ring, End Plug
47	402669	1	Pin, Trigger	99	401974	4	Screw
48	402668	1	Retaining Washer	100	404046	1	Wear Plate Kit
50	091880	1	Roll Pin, 3/32" Dia. x 5/8" Lg.	101	016343	1	Socket Head Capscrew, #8-32 x 1-1/4"
51	402404	1	Trigger				

\* Denotes normal wear items

\*\* NOTE: Make sure warning printed on Air Diffuser (#402448) is legible – replace if necessary.

Δ Apply Loctite 242 (Blue) Part No. 093500



## WARNING

All parts must be periodically inspected and replaced if worn or broken. Failure to do this can affect the tool's operation and present a safety hazard.

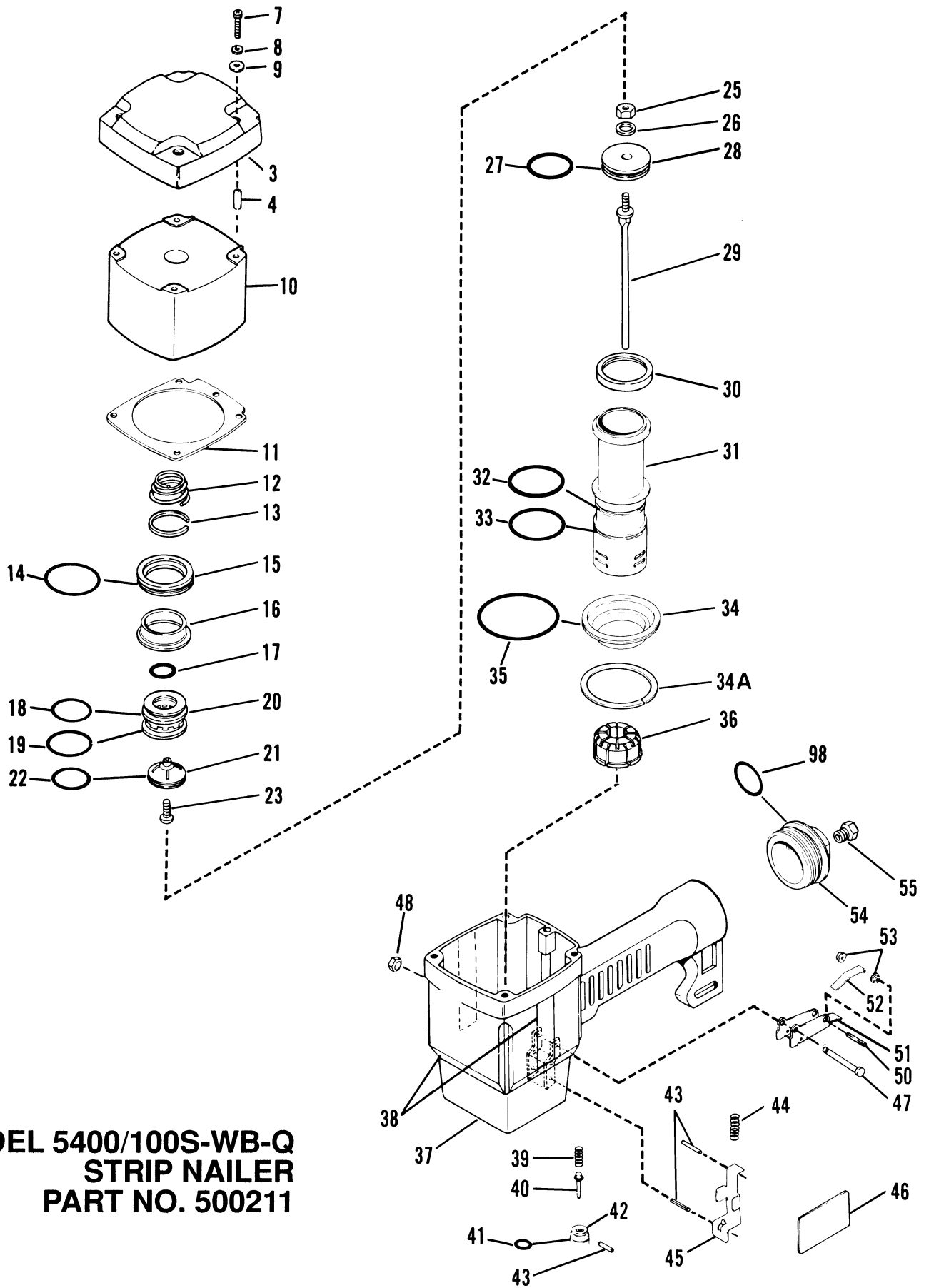

**MODEL 5400/100S-WB-Q  
STRIP NAILER  
PART NO. 500211**

**MODEL 5400/100S-WB-Q  
STRIP NAILER  
PART NO. 500211**

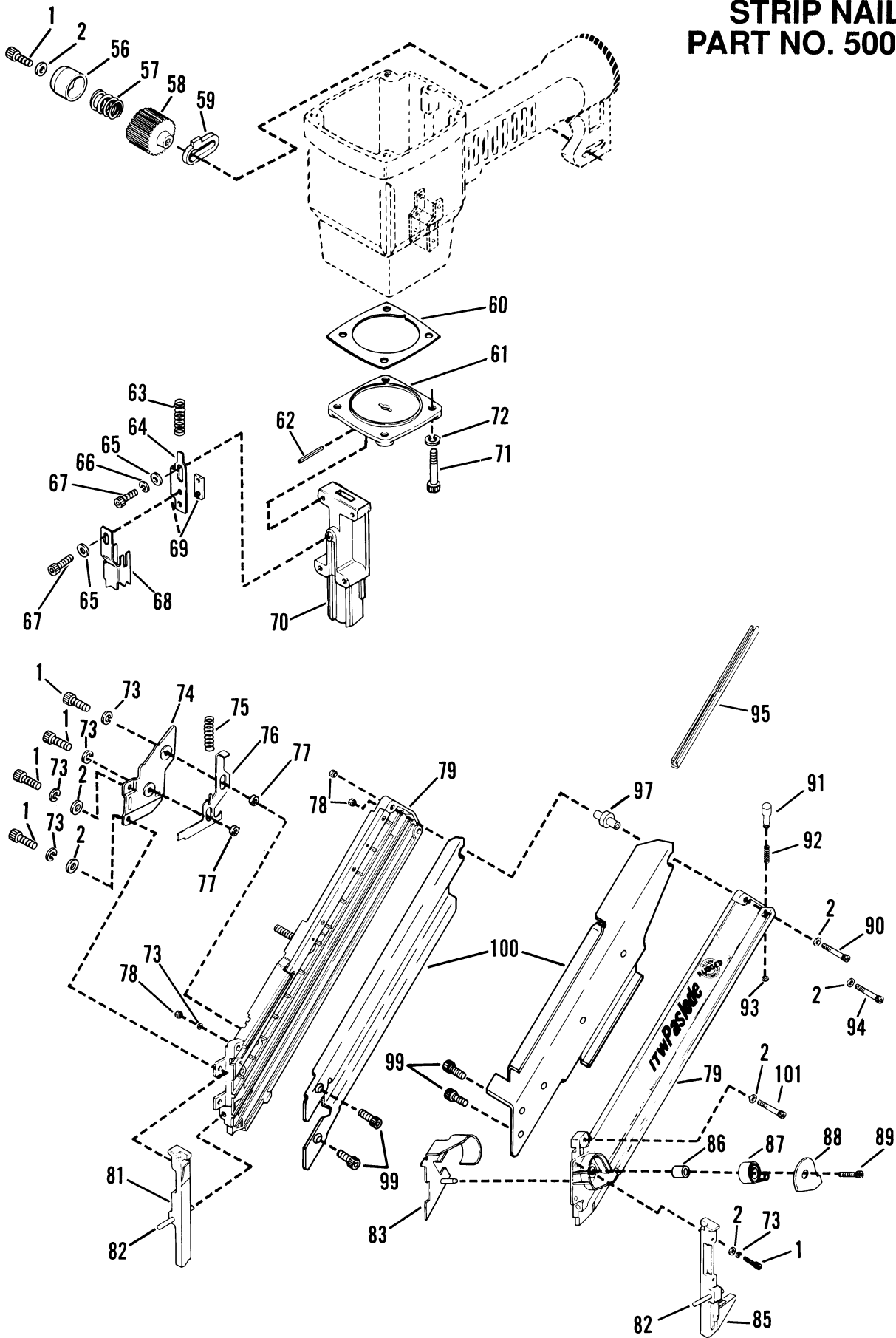

## PARTS OFFERED AS ASSEMBLIES

### 402987 Valve Assembly

**Includes:**

13	401953	1	Retaining Ring
14	401952	1	"O" Ring
15	401947	1	Upper Valve Piston
16	401946	1	Seal, Main Valve
17	401951	1	"O" Ring
18	091208	1	"O" Ring
19	401950	1	"O" Ring
20	401948	1	Lower Valve Piston

### 404811 Piston Assembly

**Includes:**

25	091861	1	Nut
26	092116	1	Washer
27	091863	1	"O" Ring
28	500077	1	Piston
29	401905	1	Driver Blade

MODEL 5400/100S-WB-Q

STRIP NAILER

PART NO. 500211

HEIGHT:

16.88 IN., 428.6 MM

LENGTH:

18.4 IN., 467 MM

TOOL WEIGHT (EMPTY):

10 LBS 14 OZ. 4.9 KG

AIR REQUIRED AT 100 PSI/6.9 BAR:

.095 FT<sup>3</sup>/CYCLE

CYCLES PER SECOND: 8

NAIL CAPACITY:

84 MAXIMUM

OPERATING PRESSURE:

80 - 120 PSI

5.5 - 8.3 BAR

MINIMUM AIR LINE REQUIRED:

3/8 ID - .95 MM

MINIMUM AIR FITTING SIZE:

3/8 DIA. - 9.5 MM

AIR CONSUMPTION CHART

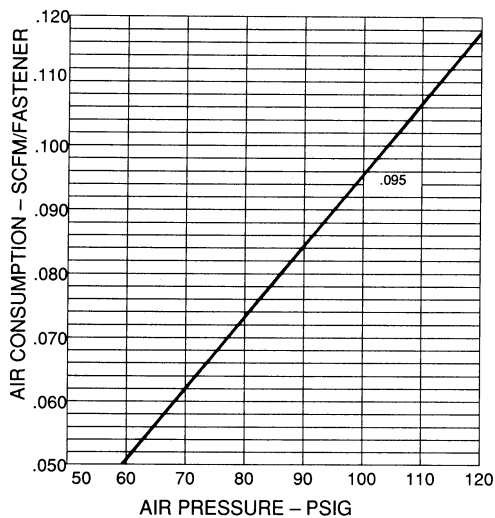

### 402408 Trigger Assembly

**Includes:**

50	091880	1	Roll Pin, 3/32" Diameter x 5/8"
51	402404	1	Trigger
52	402401	1	Lever
53	402396	2	Bushing, Lever

### 403849 Magazine Assembly

**Includes:**

1	013625	2	Socket Head Capscrew, #8-32 x 1/2"
2	401955	1	Flat Washer, #8
74	401979	1	Magazine Cover
75	401978	1	Spring, Upper Work Contacting Element
76	401977	1	Upper Work Contacting Element
77	402010	2	Bushing
78	091363	3	Flexloc Thin Nut
79	403733	1	Magazine, Left and Right
83	401966	1	Follower Assembly
86	401965	1	Drum, Negator
87	401964	1	Spring, Negator
88	403042	1	Spring Cover
89	008731	1	Socket Head Capscrew, #10-24 x 3/4"
90	404045	1	Socket Head Capscrew, #8-32 x 1-1/8"
91	403738	1	Pin, Magazine
92	403739	1	Spring, Magazine Pin
93	023766	1	Retainer Ring
94	090971	1	Socket Head Capscrew, #8-32 x 7/8"
95	401961	1	Channel
97	403740	1	Spacer, Magazine
99	401974	4	Screw
100	404046	1	Wear Plate Kit
101	016343	1	Socket Head Capscrew, #8-32 x 1-1/4"

## SAFETY INSTRUCTIONS

• **WEAR EYE & HEARING PROTECTION**



Always wear hearing protection and eye protection devices, including side shields when operating or working in the vicinity of a tool.



• **DO NOT EXCEED MAXIMUM RECOMMENDED AIR PRESSURE**

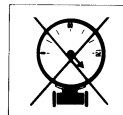

Operate the tool using only the recommended air pressure. Do not exceed the maximum air pressure marked on the tool. Be sure the air pressure gauge is operating properly and check it at least twice a day.



Never use any bottled air or gases such as oxygen to operate the tool since they could cause the tool to explode.