



SERVICE PARTS LIST

BULLETIN NO.
54-28-0400

SPECIFY CATALOG NO. AND SERIAL NO. WHEN ORDERING PARTS		REVISED BULLETIN	DATE
120V, VAC-U-RIG ATTACHMENT KIT			July '80
CATALOG NO. 49-22-7070	STARTING SERIAL NO.	WIRING INSTRUCTION	

REFER TO BULLETIN NO. 54-34-0140
FOR VACUUM PUMP ASSEMBLY

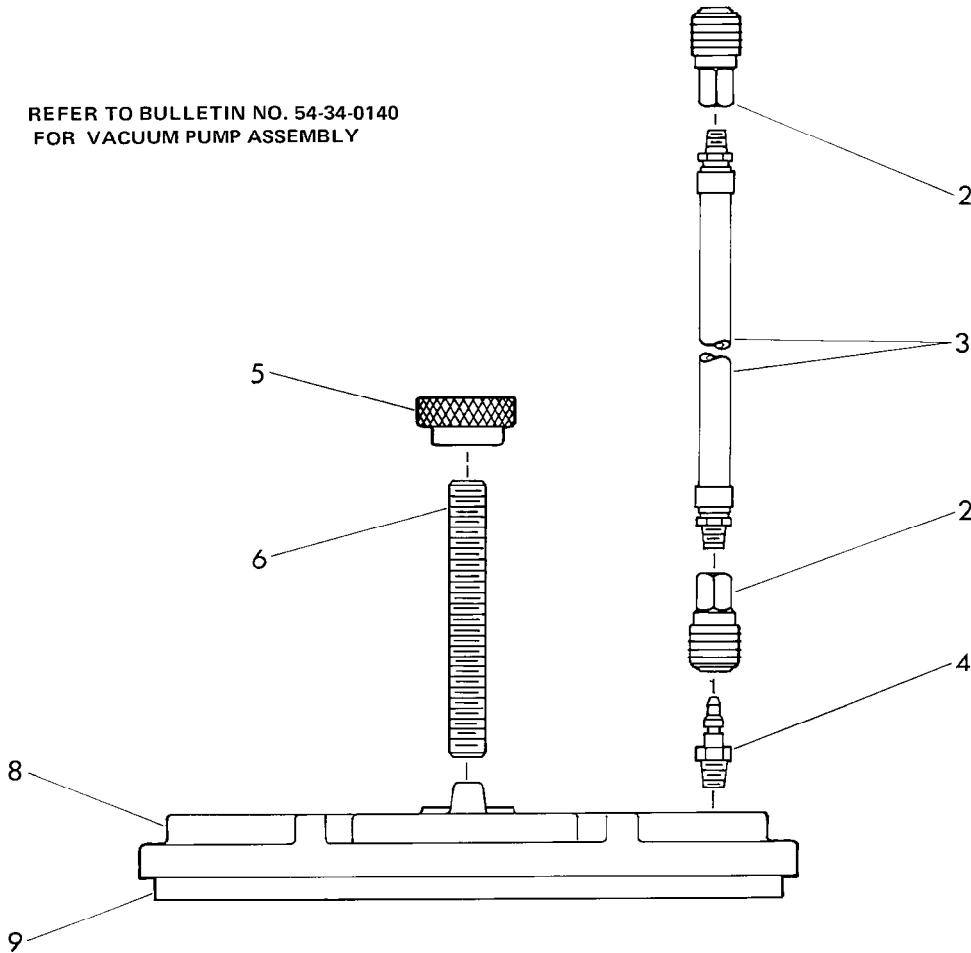

FIG.	PART NO.	DESCRIPTION OF PART	NO. REQ.
1	49-22-7070	120V Vac-U-Rig Attachment Kit Includes Fig. Nos. 2 thru 9 and Cat. No. 49-50-0140 120V Vacuum Pump Assembly Shown on Bulletin 54-34-0140	(1)
2	42-90-0120	Female Coupling	(2)
3	14-37-0150	96" Hose Assembly	(1)
4	42-90-0110	Male Coupling	(1)
5	44-40-0200	Hold Down Nut	(1)
6	06-92-1600	6" Vacuum Pad Stud	(1)
7	14-65-0210	Vacuum Pad Assembly (Includes Fig. Nos. 8 & 9)	(1)
8	-	Vacuum Pad	(1)
9	43-44-0570	Vacuum Pad Gasket	(1)