



SERVICE PARTS LIST

VACUUM ATTACHMENT KIT

Cat.No. 49-22-7060

Starting
Serial No.

BUL. 54-28-0200

REVISED BUL.

DATE

Dec.'76

WIRING INSTRUCTIONS

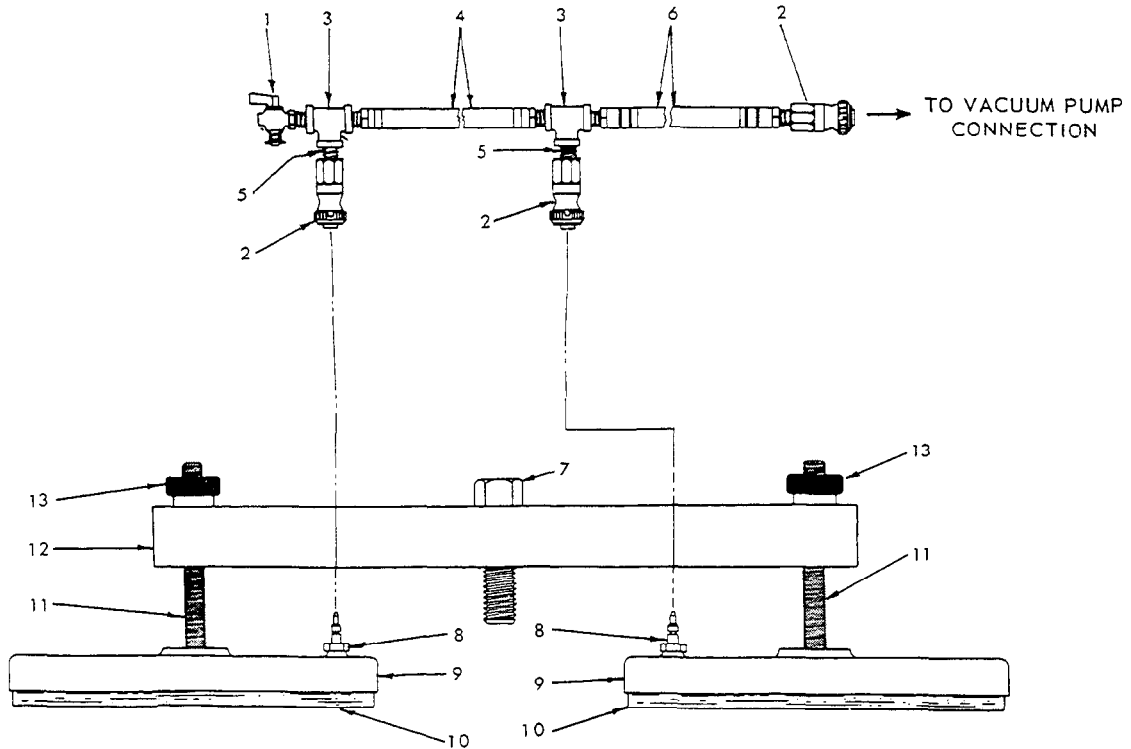

FIG.	PART NO.	DESCRIPTION OF PART	NO. REQ.
1	45-80-0080	1/4" Air Lock Valve	(1)
2	42-90-0120	Female Disconnect	(3)
3	43-33-0200	1/4" Tee	(2)
4	14-37-0100	1/2" Hose Assembly	(1)
5	43-33-0210	1/4" Close Nipple	(2)
6	14-37-0150	96" Hose Assembly	(1)
7	06-75-0970	Cross Bar Screw	(1)
8	42-90-0110	Male Disconnect	(2)
9	14-14-0100	Vacuum Disc Assembly (Includes Fig.10)	(2)
10	43-44-0090	Vacuum Disc Gasket	(2)
11	06-92-2000	Stud	(2)
12	42-18-0070	Cross Bar	(1)
13	44-40-0200	Hold Down Nut	(2)
14	49-50-0115	Vacuum Pump (Not Shown) Refer to Bulletin 54-34-0110	
	49-50-0100	Vacuum Pump (Previous Model) Refer to Bulletin 54-34-0100	