



SERVICE PARTS LIST

BULLETIN NO.
54-04-0331

SPECIFY CATALOG NO. AND SERIAL NO. WHEN ORDERING PARTS			REVISED BULLETIN	DATE
CHARGER			54-04-0330	June 2004
CATALOG NO.	48-59-0255	SERIAL NUMBER	A28B	
			WIRING INSTRUCTION	

EXAMPLE:

00 0

Component Parts (Small #)
Are Included When Ordering
The Assembly (Large #).

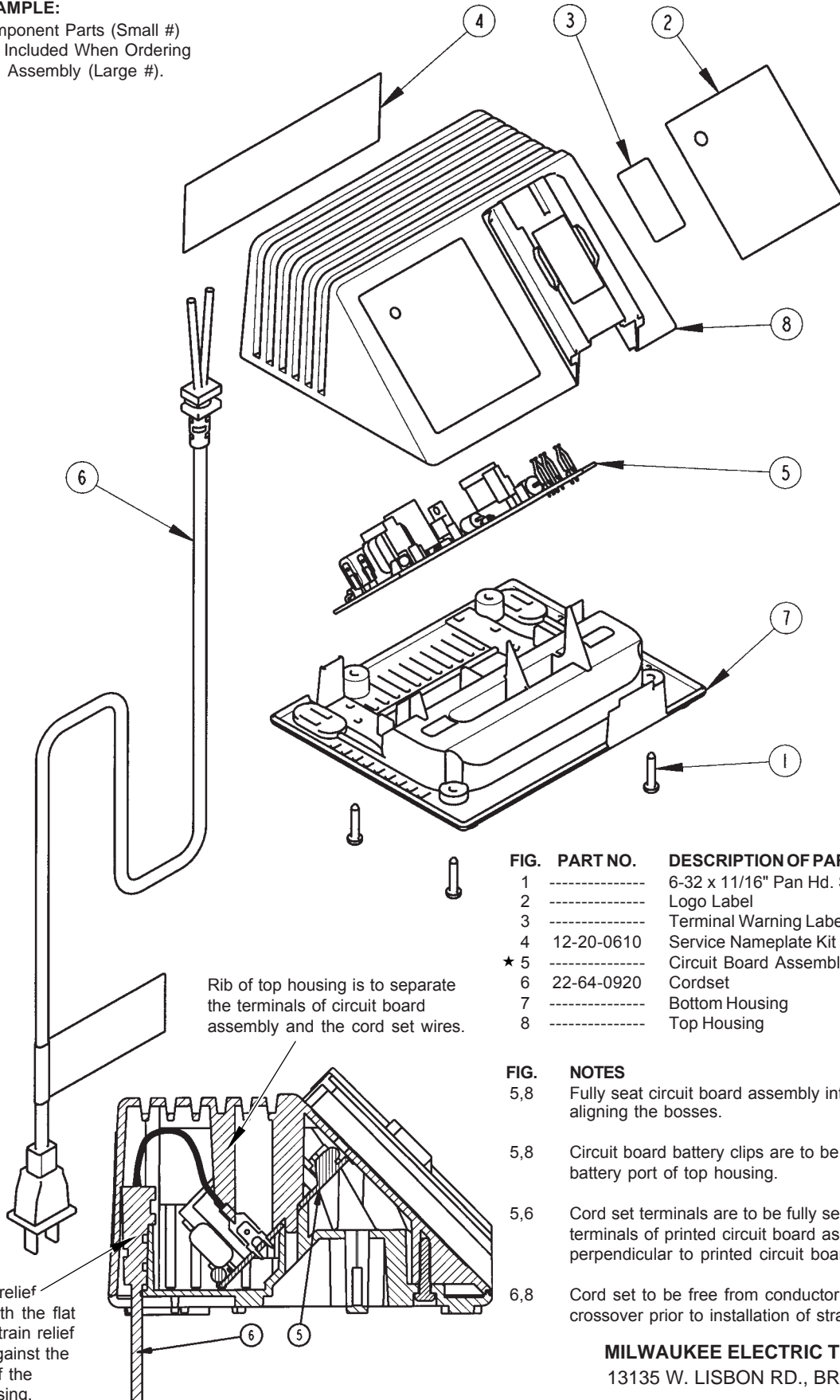

Rib of top housing is to separate the terminals of circuit board assembly and the cord set wires.

Insert strain relief as shown with the flat side of the strain relief positioned against the inside wall of the charger housing.

FIG.	PART NO.	DESCRIPTION OF PART	NO. REQ.
1	-----	6-32 x 11/16" Pan Hd. Sit. PT T-10	(4)
2	-----	Logo Label	(1)
3	-----	Terminal Warning Label	(1)
4	12-20-0610	Service Nameplate Kit	(1)
★ 5	-----	Circuit Board Assembly	(1)
6	22-64-0920	Cordset	(1)
7	-----	Bottom Housing	(1)
8	-----	Top Housing	(1)

- FIG. NOTES**
- 5,8 Fully seat circuit board assembly into top housing, aligning the bosses.
 - 5,8 Circuit board battery clips are to be fully inserted into battery port of top housing.
 - 5,6 Cord set terminals are to be fully seated on mating terminals of printed circuit board assembly and perpendicular to printed circuit board surface.
 - 6,8 Cord set to be free from conductor twists and cord crossover prior to installation of strain relief into top housing.

MILWAUKEE ELECTRIC TOOL CORPORATION
13135 W. LISBON RD., BROOKFIELD, WI 53005