



SERVICE PARTS LIST

BULLETIN NO.
55-40-0600

SPECIFY CATALOG NO. AND SERIAL NO. WHEN ORDERING PARTS		REVISED BULLETIN	DATE
BAND SAW TABLE			Feb. 2011
CATALOG NO. 48-08-0260	STARTING SERIAL NO.	WIRING INSTRUCTION	

EXAMPLE:

00	0
----	---

 Component Parts (Small #)
 Are Included When Ordering
 The Assembly (Large #).

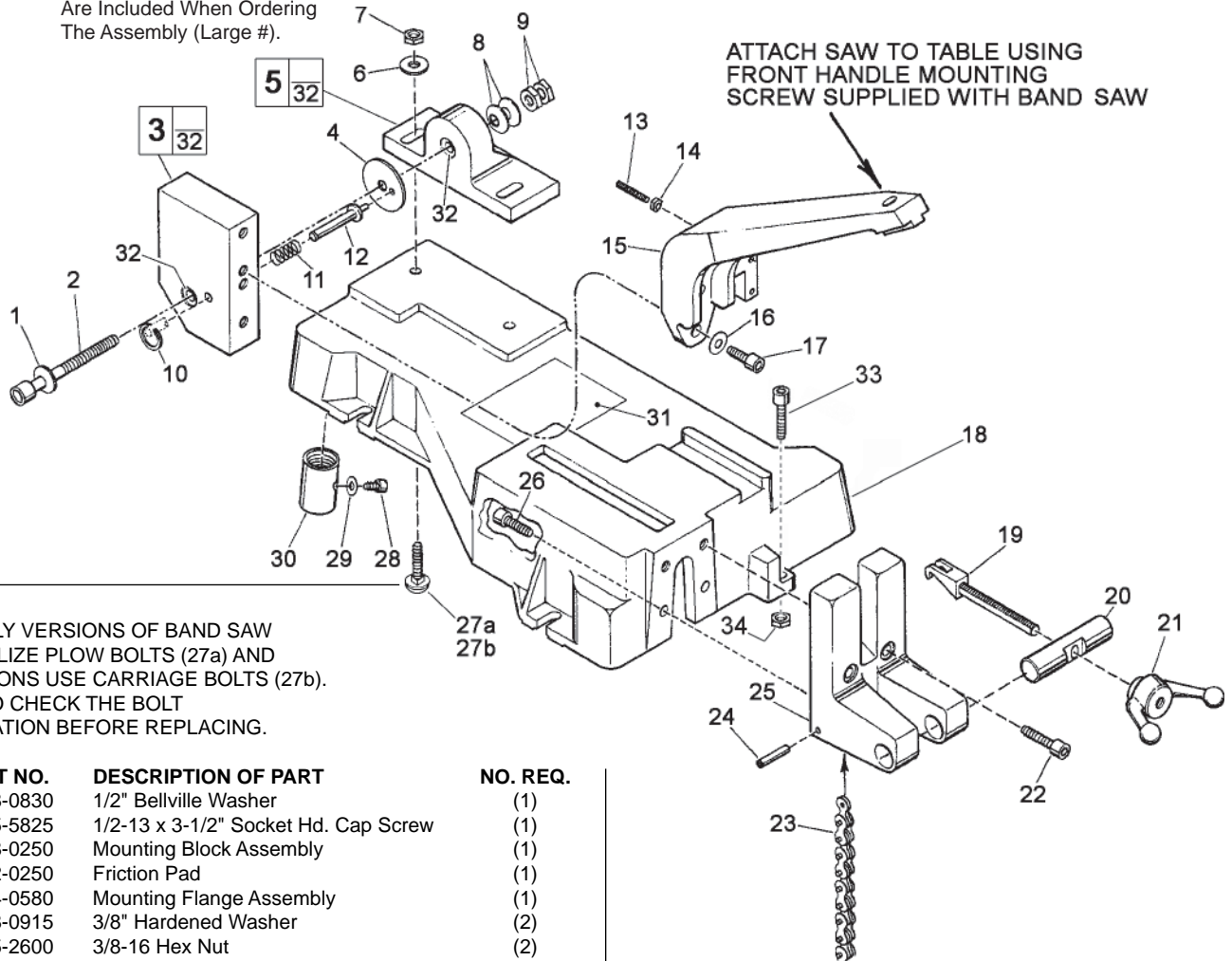

NOTE: EARLY VERSIONS OF BAND SAW TABLES UTILIZE PLOW BOLTS (27a) AND NEW VERSIONS USE CARRIAGE BOLTS (27b). BE SURE TO CHECK THE BOLT CONFIGURATION BEFORE REPLACING.

FIG.	PART NO.	DESCRIPTION OF PART	NO. REQ.
1	45-88-0830	1/2" Bellville Washer	(1)
2	06-75-5825	1/2-13 x 3-1/2" Socket Hd. Cap Screw	(1)
3	42-28-0250	Mounting Block Assembly	(1)
4	44-52-0250	Friction Pad	(1)
5	43-34-0580	Mounting Flange Assembly	(1)
6	45-88-0915	3/8" Hardened Washer	(2)
7	06-55-2600	3/8-16 Hex Nut	(2)
8	45-88-0830	1/2" Bellville Washer	(2)
9	06-57-4980	1/2-13 Jam Nut	(2)
10	44-90-0290	Split Ring 1" O.D.	(1)
11	40-50-2710	Lock Pin Spring	(1)
12	44-60-0840	Locking Pin	(1)
13	06-83-2690	1/4-20 x 1-3/4" Socket Hd. Set Screw	(2)
14	06-55-1525	1/4-20 Hex Nut	(2)
15	28-10-0325	Bandsaw Mounting Bracket	(1)
16	45-88-0915	3/8" Hardened Washer	(2)
17	06-75-4675	3/8-16 x 1" Socket Hd. Cap Screw	(2)
18	42-20-0620	Base	(1)
19	43-74-0110	Chain Hook	(1)
20	44-60-0850	Swivel Pin	(1)
21	44-40-0610	Crank Nut	(1)
22	06-75-4696	3/8-16 x 1-1/4" Socket Hd. Cap Screw	(2)
23	42-60-0130	Chain 5/8" Pitch x 21" Long	(1)
24	06-65-1585	3/16 x 1" Roll Pin	(1)
25	42-68-0540	Mounting Vise	(1)
26	06-75-4696	3/8-16 x 1-1/4" Socket Hd. Cap Screw	(2)
27a	42-32-0250	3/8-16 x 1-1/2" Plow Bolt	(2)
27b	06-10-1205	3/8-16 x 1-1/2" Carriage Bolt	(2)
28	06-75-3925	5/16-18 x 5/8" Socket Hd. Cap Screw	(4)
29	45-88-1020	5/16" Flat Washer	(4)
30	42-90-0180	3/4" N.P.T. Galv. Coupling	(4)
31	-----	Warning Label	(1)
32	42-40-0820	Bushing	(2)
33	06-75-4696	3/8-16 x 1-1/4" Socket Hd. Cap Screw	(1)
34	06-55-2600	3/8-16 Hex Nut	(1)
	49-96-0120	5/16" Allen Wrench (Not Shown)	(1)