



SERVICE PARTS LIST

PAGE 1 OF 2
BULLETIN NO.
55-46-0400

SPECIFY CATALOG NO. AND SERIAL NO. WHEN ORDERING PARTS		REVISED BULLETIN	DATE
MAG STAND ASSEMBLY			Mar. 2013
CATALOG NO. 4270-50	STARTING SERIAL NUMBER 373A	DRILL MOTOR WIRING INSTRUCTION 58-03-1840	
		MAG STAND WIRING INSTRUCTION 55-30-0450	

EXAMPLE:
 Component Parts (Small #) Are Included When Ordering The Assembly (Large #).

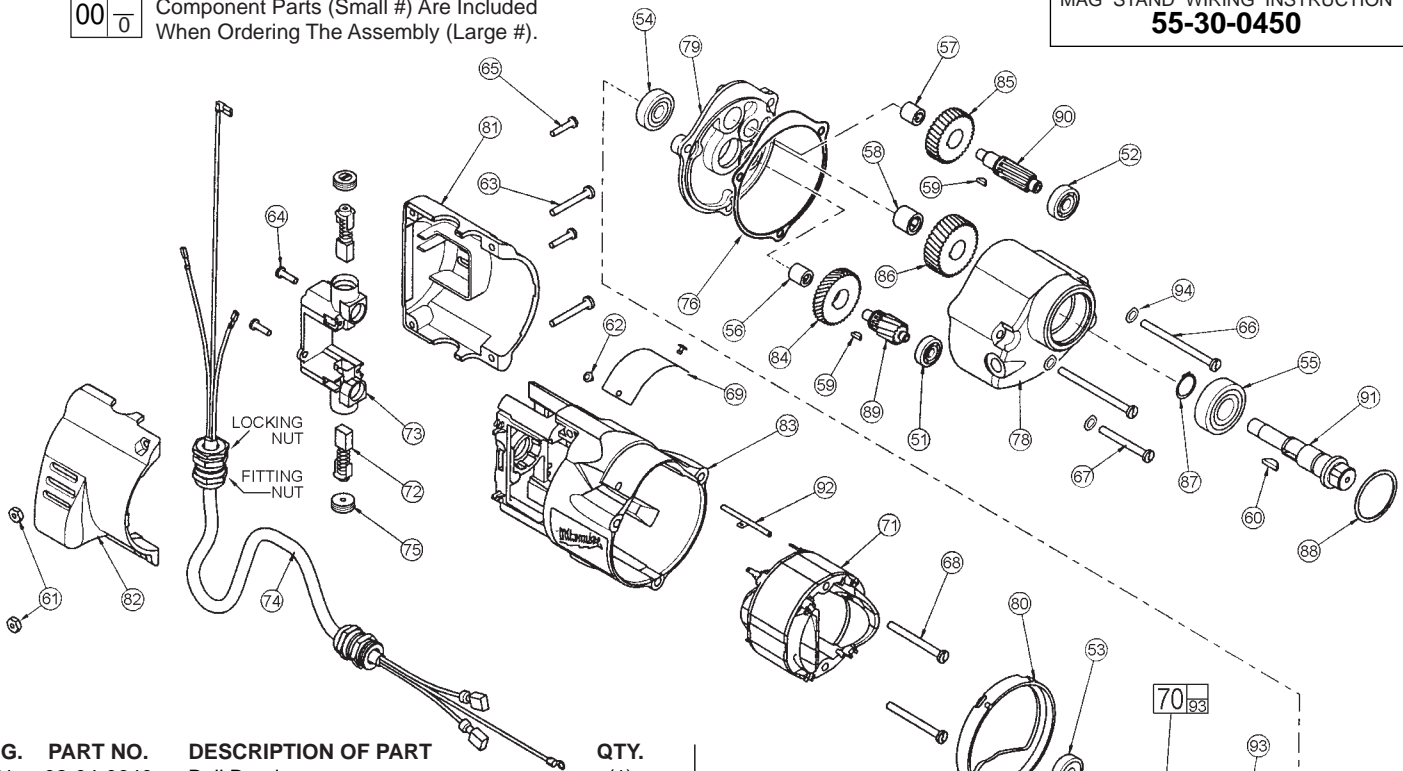

FIG.	PART NO.	DESCRIPTION OF PART	QTY.
51	02-04-0640	Ball Bearing	(1)
52	02-04-0820	Ball Bearing	(1)
53	02-04-0845	Ball Bearing	(1)
54	02-04-0911	Ball Bearing	(1)
55	02-04-1536	Ball Bearing	(1)
56	02-50-1640	Needle Bearing	(1)
57	02-50-1645	Needle Bearing	(1)
58	02-50-2440	Needle Bearing	(1)
59	06-42-0800	Woodruff Key	(2)
60	06-42-2000	Woodruff Key	(1)
61	06-55-0835	Hex Nut	(2)
62	06-72-1710	Nameplate Rivet	(2)
63	06-82-2390	8-32 x 1-1/4" Pan Hd. Slotted T-20	(2)
64	06-82-7240	6-19 x .50 Pan Hd. Slotted Plastite T-15	(2)
65	06-82-9207	6-19 x .708 Pan Hd. PT Screw T-10	(2)
66	06-82-7375	8-16 x 2.50 Pan Hd. Slotted Plastite T-20	(2)
67	06-82-7382	8-16 x 1.625 Pan Hd. Slotted Plastite T-20	(1)
68	06-82-7410	8-16 x 1.875 Pan Hd. Slotted Plastite T-20	(2)
69	12-99-3360	Service Nameplate	(1)
70	16-34-0490	Armature	(1)
71	18-32-0532	Field	(1)
72	22-18-1015	Carbon Brush Assembly	(2)
73	22-22-1385	Brush Holder Assembly	(1)
74	22-64-3295	Motor Cord Assembly	(1)
75	23-44-0125	Brush Holder Cap	(2)
76	43-44-1075	Gasket	(1)
78	28-14-1922	Gearcase	(1)
79	28-28-0611	Diaphragm	(1)
80	31-05-0055	Baffle	(1)
81	31-15-2060	Motor Cover-Left Half	(1)
82	31-15-2061	Motor Cover-Right Half	(1)
83	31-50-0020	Motor Housing	(1)
84	32-40-1251	Intermediate Gear	(1)
85	32-75-2051	2nd Intermediate Gear	(1)
86	32-75-2651	Spindle Gear	(1)
87	34-60-1200	External Retaining Ring	(1)
88	34-80-2500	Retaining Ring	(1)
89	36-66-2811	Intermediate Pinion	(1)

FIG.	PART NO.	DESCRIPTION OF PART	QTY.
90	36-66-3980	2nd Intermediate Pinion	(1)
91	38-50-5485	Spindle	(1)
92	44-60-0530	Grounding Pin	(1)
93	22-84-0531	Fan	(1)
94	43-44-1160	Screw Gasket	(3)
	23-94-6120	Leadwire Assembly (Not Shown)	(1)
	23-94-6370	Leadwire Assembly (Not Shown)	(1)

- FIG. 53** NOTES:
 Ball bearing seal to face towards the commutator.
- 53,54,70 Press ball bearings to armature shaft shoulder.
- 56,57,79 Press needle bearings to .105 ± .005 above machined face of diaphragm.
- 74,81,82 Using a 22mm crows foot wrench, apply 40 in/lbs of torque to fitting nut and to locking nut when assembling the motor cord assembly to the motor covers.

FIG. 51,78 LUBRICATION:
 Apply 3.75 oz. type "Y" grease, No. 49-08-5270 near ball bearing #1 in gearcase.

SEE BULLETIN NO. 55-30-0450 FOR OPERATIONAL CHECK LIST AND WIRING INSTRUCTIONS FOR MAG STANDS

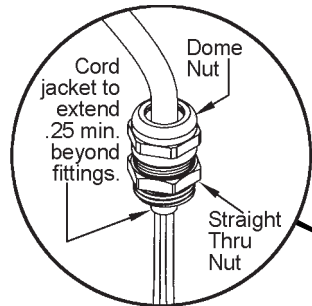

Using a 22mm crows foot wrench, apply 40 in/lbs of torque to the straight thru fitting and to the dome nut when assembling the motor cord to the stand.

EXAMPLE:
 00 0 Component Parts (Small #)
 Are Included When Ordering
 The Assembly (Large #).

Using a 7/8" crows foot wrench, apply 45 in/lbs of torque to the pigtail fitting and 35 in/lbs of torque to the locking nut when assembling the power cord (17) to the control panel (18).

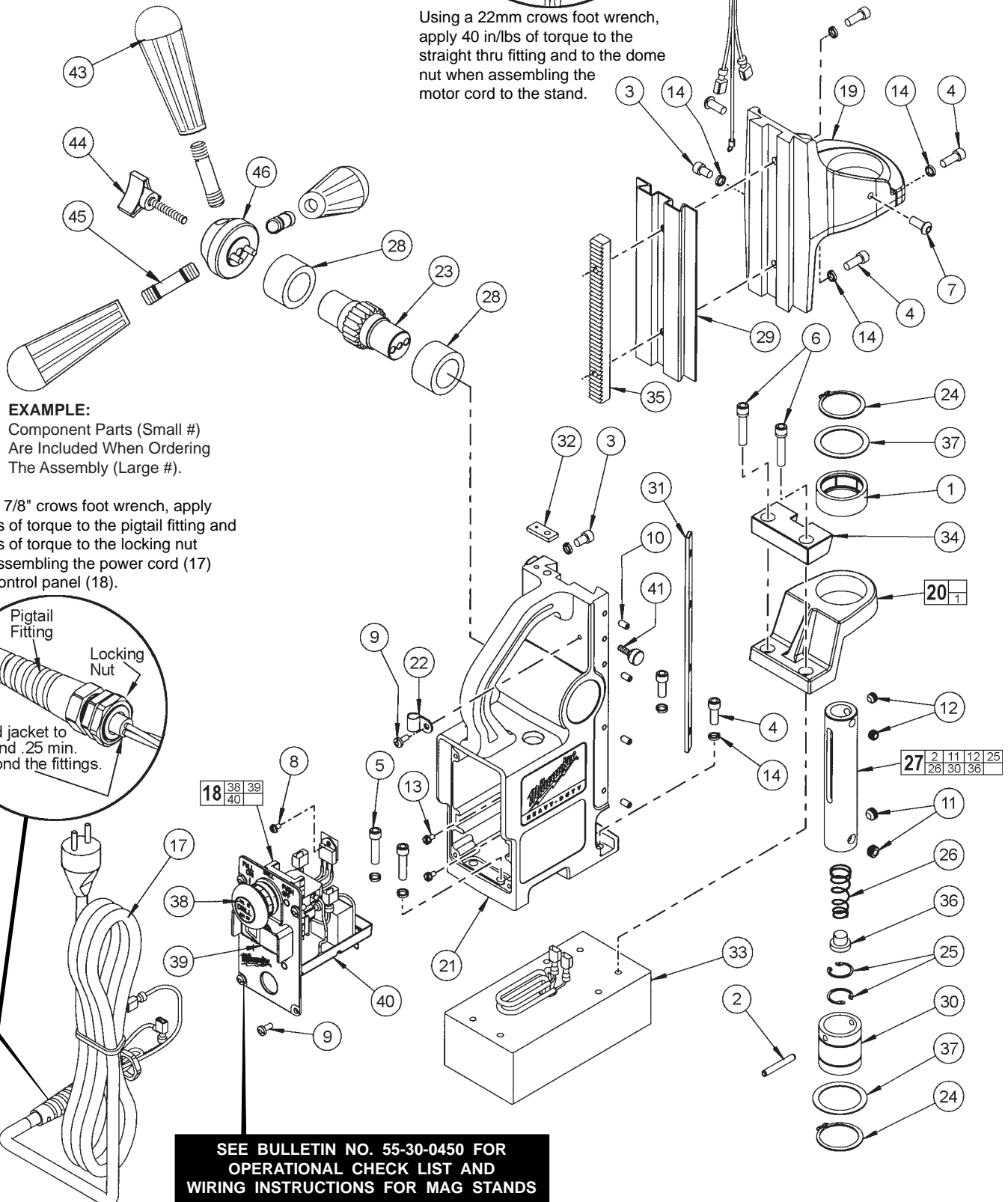
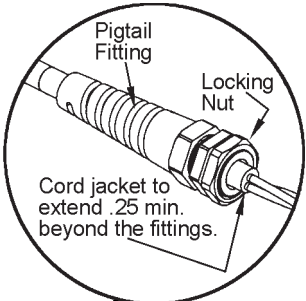

SEE BULLETIN NO. 55-30-0450 FOR OPERATIONAL CHECK LIST AND WIRING INSTRUCTIONS FOR MAG STANDS

FIG.	PART NO.	DESCRIPTION OF PART	QTY.	FIG.	PART NO.	DESCRIPTION OF PART	QTY.
1	-----	Needle Bearing	(1)	36	-----	Spring Seat	(1)
2	-----	Roll Pin	(1)	37	45-14-0290	Shim	(2)
3	06-75-2900	1/4 x 3/8" Socket Head Screw	(2)	38	23-66-2315	Drill Switch Assembly	(1)
4	06-75-3005	1/4 x 5/8" Socket Head Screw	(5)	39	23-66-2295	Magnet Switch	(1)
5	06-75-3100	1/4-20 x 1.00" Socket Head Screw	(2)	40	14-20-1205	Potted PCB Kit	(1)
6	06-75-5865	1/4-20 x 1.25" Socket Head Sems Screw	(2)	41	06-87-2570	Stop Knob	(1)
7	06-81-4770	1/4-20 x 5/8" Button Head Cap Screw	(2)	43	43-98-0095	Plastic Knob	(3)
8	06-81-8655	6-32 x 1/4" Hex Hd. Sems Screw	(1)	44	06-87-2550	Handle Screw	(1)
9	06-82-7252	8-32 x .38 Taptite Screw T-20	(5)	45	43-62-0090	Feed Handle	(3)
10	06-83-1650	10-32 x 1/2" Set Screw	(4)	46	14-46-5400	Handle Hub Kit	(1)
11	06-83-5170	3/8-24 x 1/4" Flat Point Set Screw	(2)		48-58-0090	4' Safety Strap (Not Shown)	(1)
12	06-83-6015	5/16-24 x 1/4" Set Screw	(2)		49-96-0050	3/32" Hex Key (Not Shown)	(1)
13	06-81-8625	6-32 Slit. Hex Hd. Sems Machine Screw	(2)		49-96-0090	3/16" Hex Key (Not Shown)	(1)
14	06-97-4050	1/4" Split Ring Lock Washer	(9)				
16	-----	Danger Label	(1)				
17	22-64-0950	Power Cord Assembly	(1)				
18	23-35-0380	Panel Assembly (See Bulletin No. 55-30-0450)	(1)				
19	28-10-0099	Motor Bracket	(1)				
20	14-46-5405	Stabilizer and Needle Bearing Kit	(1)				
21	28-50-0600	Mag Stand	(1)				
22	31-17-0185	Cable Clamp	(1)				
23	32-60-0200	Pinion Gear	(1)				
24	34-60-3690	Retaining Ring-External	(2)				
25	-----	Retaining Ring-Internal	(2)				
26	-----	Conical Pilot Pin Spring	(1)				
27	14-73-0290	Cutter Shaft Kit	(1)				
28	42-40-0060	Bushing	(2)				
29	42-40-1055	Dovetail Cover	(1)				
30	-----	Stationary Collar	(1)				
31	43-48-0150	Gib Plate	(1)				
32	43-94-0070	Wrench Keeper	(1)				
33	44-26-0080	Electromagnet	(1)				
34	44-66-6220	Spacer	(1)				
35	44-80-0200	Rack	(1)				

23-35-0380 TROUBLE SHOOTING			
ACTION	RESPONSE	POSSIBLE CAUSE	SOLUTION
Magnet is "on". Drill switch is "on".	Tool does not operate. Magnet switch lamp is "on".	1. Drill switch was "on" when magnet was turned "on".	1. Turn drill switch "off", then back "on".
		2. Control module is damaged.	2. Replace control module.
Magnet switch is turned "on".	Magnet switch lamp turns "on", then "off".	1. Magnet is damaged.	1. Check magnet resistance, 970 to 1000 ohms.
		2. Wiring from magnet to control module is damaged.	2. Repair or replace wiring.
		3. Control module is damaged.	3. Replace control module.
		4. Voltage is too low/extension cord is too long or wrong gauge.	4. Check for 230 VAC at cord end. Check extension cord length and gauge.
Magnet switch is turned "on". Drill switch is turned "on".	Magnet switch lamp is on, turns off when drill switch is turned "on".	1. Motor brushes are worn.	1. Replace brushes.
		2. Control module is damaged.	2. Replace control module.

COMPACT ELECTROMAGNETIC DRILL PRESS 4270-50

Shown at lower and upper limits (mm) of each set-up

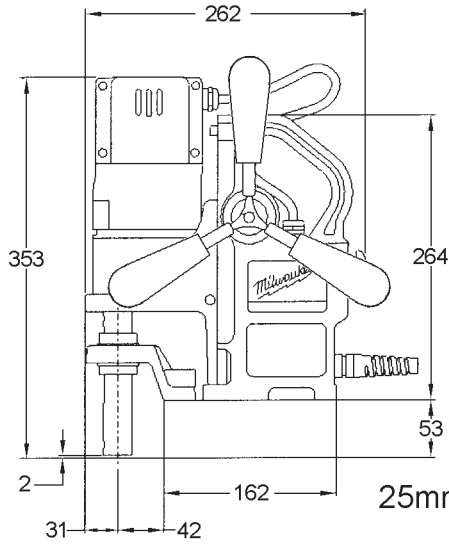
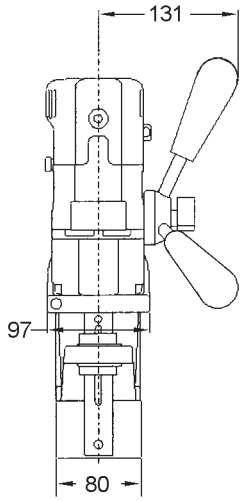

25mm DEPTH OF CUT SET-UP

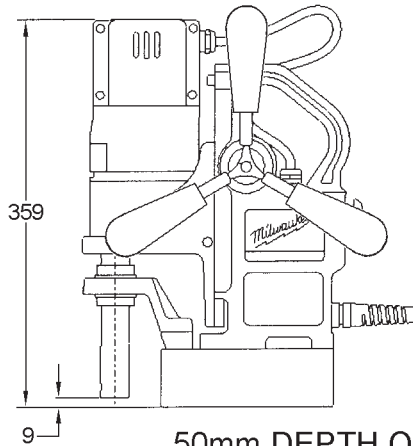
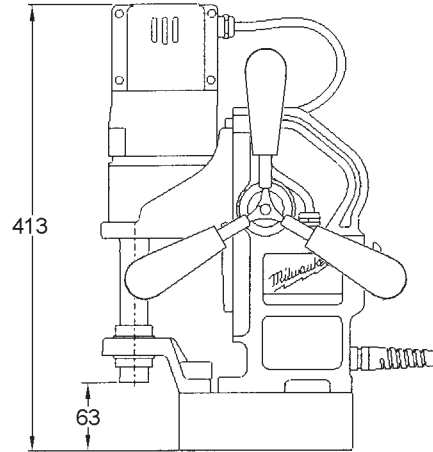

50mm DEPTH OF CUT SET-UP

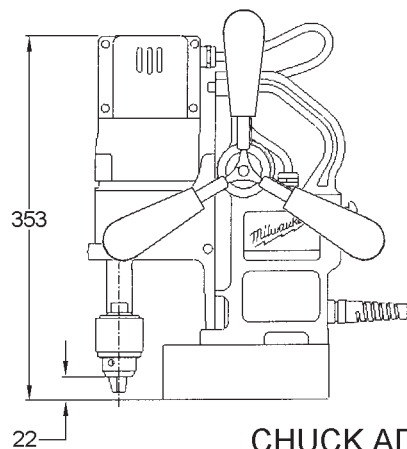
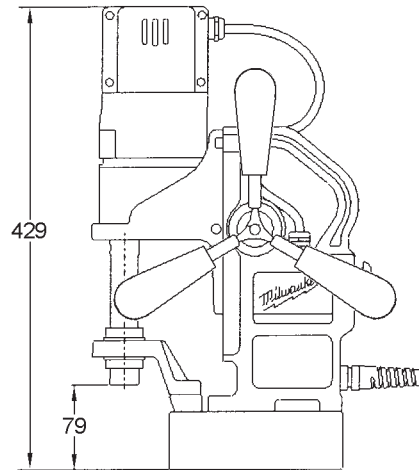

CHUCK ADAPTER SET-UP

