



Operating Instructions and Parts Manual 12"x20" Semi-Automatic Variable-Speed Mitering Band Saw

Models HBS-1220MSA, HBS-1220MSAH



JET
427 New Sanford Road
LaVergne, Tennessee 37086
Ph.: 800-274-6848
www.jettools.com

Part No. M-424476
Edition 2 11/2018
Copyright © 2018 JET

14.1.1 HBS-1220MSA/MSAH Base Assembly – Exploded View

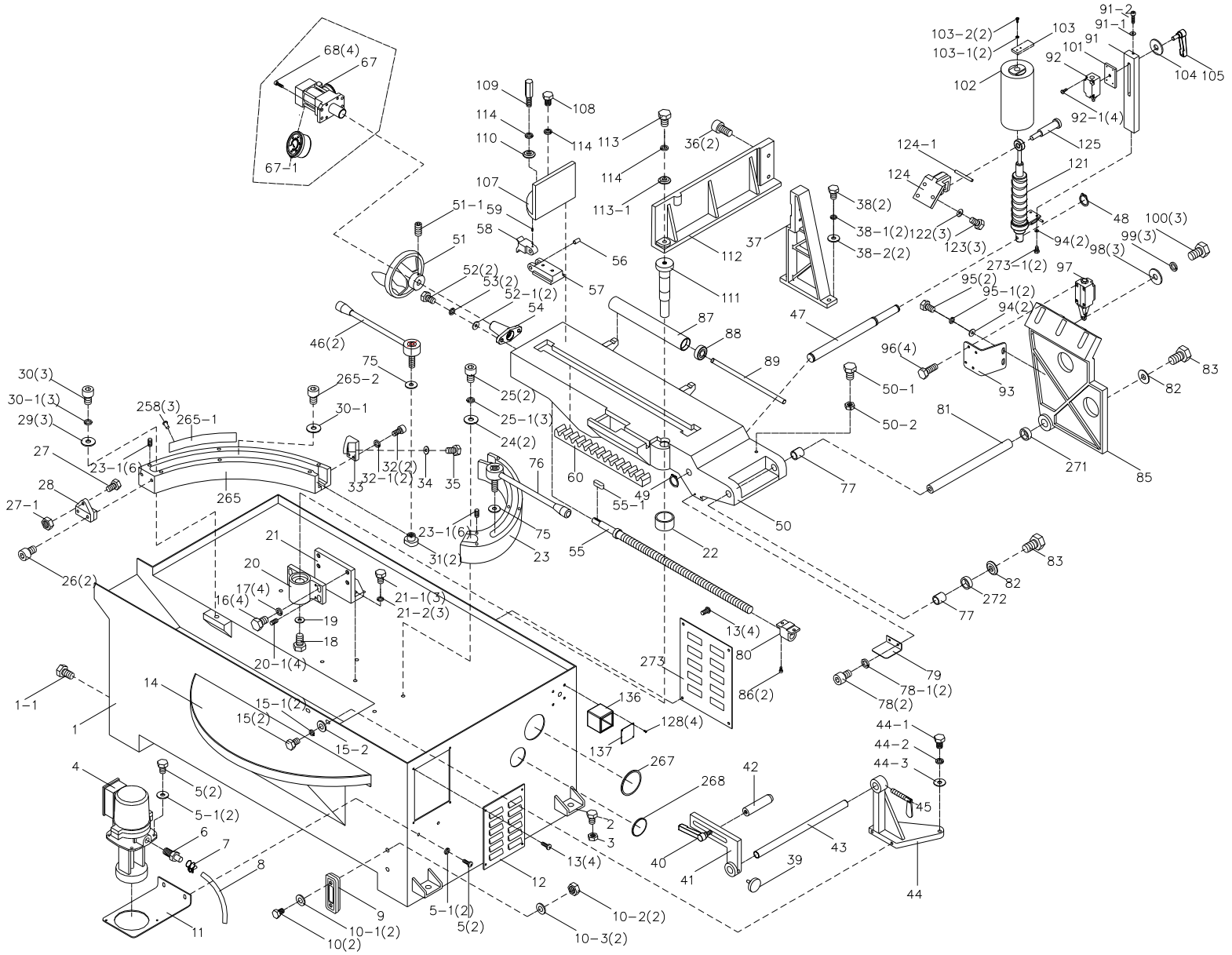

14.1.2 HBS-1220MSA/MSAH Oil Pump Assembly – Exploded View

HBS-1220MSA

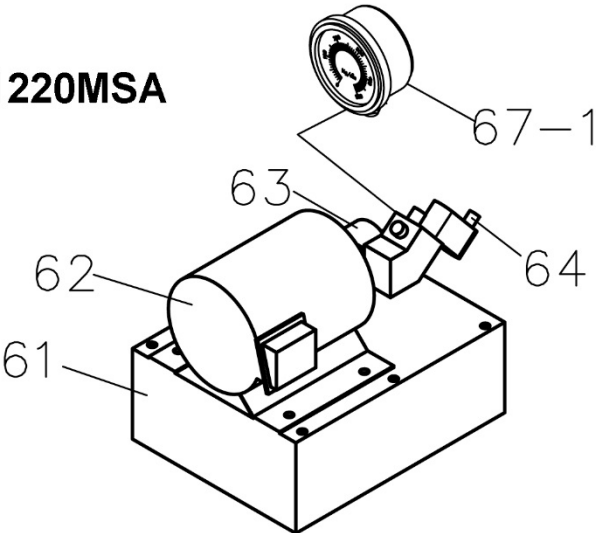

HBS-1220MSAH

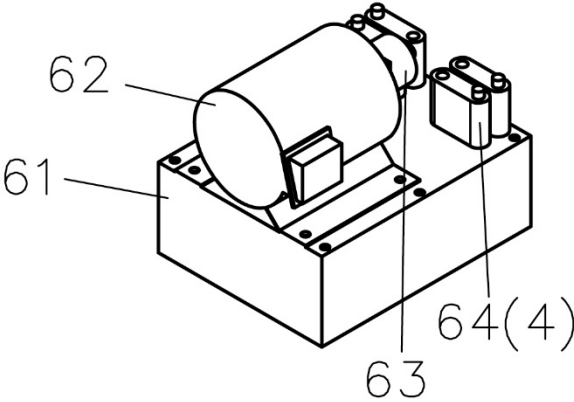

14.1.3 HBS-1220MSA/MSAH Base Assembly – Parts List

Index No	Part No	Description	Size	Qty
1	HBS1220MSA-01	Machine Base		1
1-1	5512197	Drain Plug	3/8"PT	1
2	TS-1492071	Hex Cap Screw	M12-1.75 x 70	4
3	TS-1540081	Hex Nut	M12-1.75	4
4	J-5712921A	Coolant Pump	1/8HP 230/460V 3PH	1
5	TS-1482031	Hex Cap Screw	M6-1.0 x 16	4
5-1	TS-2360121	Flat Washer	M12	4
6	5507596	Hose Fitting		1
7	5507597	Hose Clamp		1
8	5712331	Hose	5/16"	1
9	5507599	Coolant Gauge		1
10	TS-1491041	Hex Cap Screw	M10-1.5 x 30	2
10-1	HBS1220MSA-10-1	Soft Washer	M10	2
10-2	TS-1540071	Hex Nut	M10-1.5	2
10-3	TS-1550071	Flat Washer	M10	2
11	5712351	Coolant Pump Bracket		1
12	J-5512195G	Cover Panel		1
13	TS-0254011	Socket Head Button Screw	1/4"-20 x 3/8"	12
14	J-5507604G	Drip Tray		1
15	TS-1490021	Hex Cap Screw	M8-1.25 x 16	2
15-1	TS-2361081	Lock Washer	M8	2
15-2	TS-1550061	Flat Washer	M8	2
16	TS-1492021	Hex Cap Screw	M12-1.75 x 30	4
17	TS-2360121	Flat Washer	M12	4
18	TS-1490021	Hex Cap Screw	M8-1.25 x 16	1
19	TS-1550061	Flat Washer	M8	1
20	5507609	Turning Slide Bracket		1
20-1	TS-1524021	Socket Set Screw	M8-1.25 x 10	4
21	5507610	Center Fixed Bracket		1
21-1	TS-1492031	Hex Cap Screw	M12-1.75 x 35	3
21-2	TS-2361121	Lock Washer	M12	3
22	5507611	Thrust Bearing		1
23	HBS1220MSA-23	Turning Slide, Right		1
23-1	TS-1524021	Socket Set Screw	M8-1.25 x10	12
24	TS-1550071	Flat Washer	M10	2
25	TS-1505061	Socket Head Cap Screw	M10-1.5 x 40	3
25-1	TS-2361101	Lock Washer	M10	3
26	TS-1503051	Socket Head Cap Screw	M6-1.0 x 20	2
27	TS-1491041	Hex Cap Screw	M10-1.5x30	1
27-1	TS-1540071	Hex Nut	M10-1.5	1
28	5507616	Bracket		1
29	TS-1550071	Flat Washer	M10	2
30	TS-1505061	Socket Head Cap Screw	M10-1.5 x 40	2
30-1	TS-2361101	Lock Washer	M10	3
31	5512705	Sliding Nut		2
32	TS-1503071	Socket Head Cap Screw	M6-1.0x30	2
32-1	TS-2361061	Lock Washer	M6	2
33	HBS1220MSA-33	Bracket		1
34	TS-1540071	Hex Nut	M10-1.5	1
35	TS-1491031	Hex Cap Screw	M10-1.5 x 25	1
36	TS-1505031	Socket Head Cap Screw	M10-1.5 x 25	2
37	HBS1220MSA-37	Mounting Bracket		1
38	TS-149105	Hex Cap Screw	M10-1.5 x 35	2
38-1	TS-2361101	Lock Washer	M10	2
38-2	TS-1550071	Flat Washer	M10	2
39	HBS1220MSA-39	Locking Knob	3/8"-16	1
40	HBS1220MSA-40	Handle	M12 x 25	1
41	5712421	Work Stop Bracket		1
42	5712451	Work Stop		1
43	5712431	Work Stop Rod		1

Index No	Part No	Description	Size	Qty
44	J-5507628G	Support		1
44-1	TS-1503071	Socket Head Cap Screw	M6-1.0 x 30	1
44-2	TS-2361061	Lock Washer	M6	1
44-3	TS-1550041	Flat Washer	M6	1
45	HBS1220MSA-45	Thumb Screw	5/16"-18	1
46	5507630	Adjustable Handle		2
47	HBS1220MSA-47	Cylinder Lower Support Rod		1
48	5507632	C-Retaining Ring, Ext	S-20	1
49	5507633	C-Retaining Ring, Ext	S-25	2
50	HBS1220MSA-50	Bed		1
50-1	TS-1491041	Hex Cap Screw	M10-1.5 x 30	1
50-2	TS-1540071	Hex Nut	M10-1.5	1
51	HBS1220MSA-51	Handwheel Assembly		1
51-1	TS-0270051	Socket Set Screw	5/16"-18 x 1/2"	1
52	TS-1490051	Hex Cap Screw	M8-1.25 x 30	2
52-1	TS-1550061	Flat Washer	M8	2
53	TS-2361081	Lock Washer	M8	2
54	J-5512677G	Lead Screw Seat		1
55	5512183	Vise Lead Screw		1
55-1	KEY5520	Key, Dbl Rd Hd	5 x 5 x 20mm	1
56	5512122	Pin		1
57	J-5512124	Slide Bracket		1
58	J-5512125	Rack Block		1
59	TS-1523031	Socket Set Screw	M6-1.0 x 10	1
60	J-5512123	Rack		1
61	HBS1220MSA-61	Tank		1
62	5512191	Hydraulic Motor	1/2HP 230/460V 3PH	1
63	5512190	Hydraulic Pump Assembly		1
64	5512187	Solenoid Valve w/Coil	MSA	1
	5512187	Solenoid Valve w/Coil	MSAH	4
67	HBS1220MSAH-67	Vise Hydraulic Cylinder		1
67-1	HBS1220MSAH-67-1	Oil Pressure Gauge	tank side MSA, vise side MSAH	1
68	TS-1504061	Socket Head Cap Screw	M8-1.25 x 30	1
75	TS-155010	Flat Washer	M16	2
76	HBS1220MSA-76	Lock Handle		1
77	5712571	Needle Bearing		2
78	TS-1503031	Socket Head Cap Screw	M6-1.0 x 12	2
78-1	TS-2361061	Lock Washer	M6	2
79	5507654	Guide Plate		1
80	5512182	Lead Screw Seat		1
81	5512153	Pivot Shaft		1
82	TS-2360121	Flat Washer	M12	2
83	TS-1492011	Hex Cap Screw	M12-1.72 x 20	2
85	J-5512168G	Pivot Bracket		1
86	TS-2208201	Hex Cap Screw	M8-1.25 x 20	2
87	HBS1220MSA-87	Roller		1
88	BB-6302	Ball Bearing	6302	2
89	HBS1220MSA-89	Roller Shaft		1
91	HBS1220MSA-91	Adjusting Bracket		1
91-1	TS-1540061	Hex Nut	M8	1
91-2	TS-1504061	Socket Head Cap Screw	M8-1.25 x 30	1
92	5512145	Limit Switch	5101	1
92-1	TS-1504041	Socket Head Cap Screw	M8-1.25 x 20	4
93	J-5512169G	Limit Switch Plate		1
94	TS-1550061	Flat Washer	M8	4
95	TS-1490021	Hex Cap Screw	M8-1.25 x 16	2
95-1	TS-2361081	Lock Washer	M8	2
96	TS-1482011	Hex Cap Screw	M6-1.0 x 10	4
97	5512163	Limit Switch		1
98	5507671	Plate		2
99	TS-2360121	Flat Washer	M12	2
100	TS-1492051	Hex Cap Screw	M12-1.75 x 50	3

Index No	Part No	Description	Size	Qty
101	5512144	Switch Mounting Plate		1
102	5512151	Cylinder Cover		1
103	5512159	Switch Stop Plate		1
103-1	TS-2361061	Lock Washer	M6	2
103-2	TS-1503041	Socket Head Cap Screw	M6-1.0 x12	2
104	TS-1550071	Flat Washer	M10	1
105	HBS1220MSA-105	Handle		1
107	5512127	Floating Vise Jaw		1
108	TS-1492031	Hex Cap Screw	M12-1.75 x 35	1
109	5512130	Locking Bolt		1
110	HBS1220MSA-110	Beveled Washer	M12	1
111	HBS1220MSA-111	Pivot Pin		1
112	HBS1220MSA-112	Fixed Vise Jaw		1
113	TS-1492041	Hex Cap Screw	M12-1.75 x 40	1
113-1	TS-2360121	Flat Washer	M12	3
114	TS-2361121	Lock Washer	M12	5
121	HBS1220MSA-121	Hydraulic Cylinder		1
122	TS-2361101	Lock Washer	M10	3
123	TS-1491041	Hex Cap Screw	M10-1.5 x 30	3
124	J-5512162	Hydraulic Mounting Plate		1
124-1	5512148	Retaining Pin		1
125	5512147	Cylinder Pin		1
128	F009884	Socket Head Button Screw	M5-0.8x8	4
136	HBS1220MSAH-136	Wire Terminal Box		1
137	HBS1220MSAH-137	Wire Terminal Box Cover		1
258	HBS1220MSA-258	Rivet		3
265	HBS1220MSA-265	Turning Slide, Left		1
265-1	HBS1220MSA-265-1	Angle Scale		1
265-2	TS-1505031	Socket Head Cap Screw	M10-1.5 x 25	1
267	HBS1220MSA-267	Rubber Ring		1
268	HBS1220MSA-268	Rubber Ring		1
271	5521936	Bushing	3mm	1
272	5521936	Bushing	3mm	1
273	J-5512189G	Cover Panel		1
273-1	TS-1490041	Hex Cap Screw	M8x25	2
	LM000322	ID Label, HBS-1220MSA (not shown)		1
	LM000323	ID Label, HBS-1220MSAH (not shown)		1
	LM000250	Warning Label (not shown)		1
	HBS1220MSA-TB	Toolbox see sect. 6.1 for contents		1

14.2.1 HBS-1220MSA/MSAH Bow Assembly – Exploded View

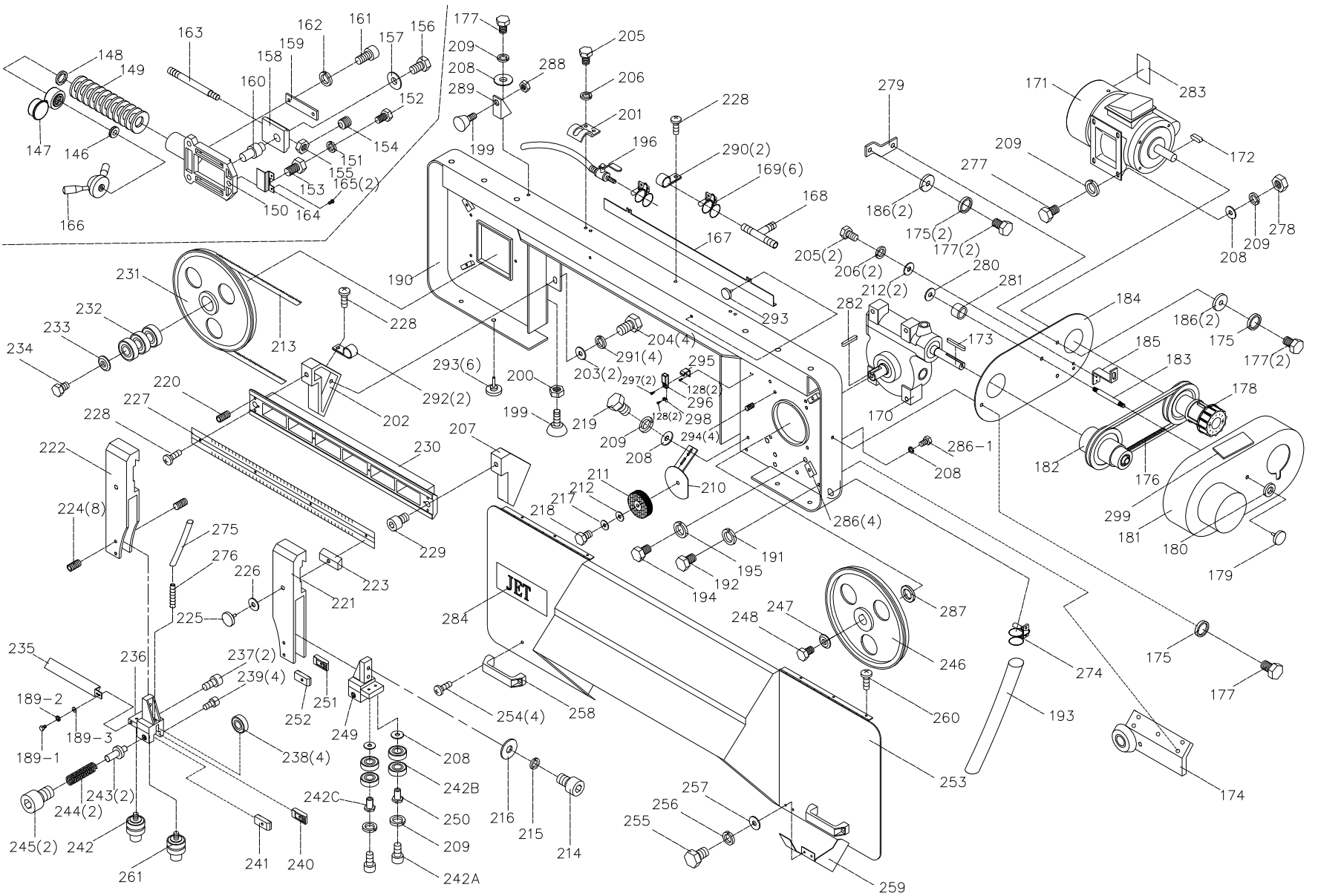

14.2.2 HBS-1220MSA/MSAH Bow Assembly – Parts List

Index No	Part No	Description	Size	Qty
146	BB-51103	Thrust Bearing	51103	1
147	HBS1220MSA-147	Hydraulic Tension Gauge		1
148	5512250	Special Washer		1
149	5512251	Special Spring Washer		18
150	J-5512252G	Slide Bracket		1
151	TS-2361101	Lock Washer	M10	3
152	TS-1491101	Hex Cap Screw	M10-1.5x60	3
153	5512255	Screw Assembly		3
154	TS-1523031	Socket Set Screw	M6-1.0x10	1
155	TS-154010	Hex Nut	M16-2.0	1
156	TS-1492011	Hex Cap Screw	M12-1.75 x25	1
157	TS-2360121	Flat Washer	M12	1
158	HBS1220MSA-158	Slide Block		1
159	J-5512260G	Gib		2
160	5512261	Blade Wheel Bracket Shaft		1
161	TS-1504041	Socket Head Cap Screw	M8-1.25x20	6
162	TS-2361081	Lock Washer	M8	6
163	HBS1220MSA-163	Tension Shaft		1
164	HBS1220MSA-164	Cover Plate		1
165	F009884	Socket Head Button Screw	M5-0.8x8	2
166	HBS1220MSA-166	Blade Tension Handle Assembly		1
167	HBS1220MSA-167	Bow Gap Cover		1
168	5512268	T-Fitting		1
169	5512269	Hose Clamp		5
170	HBS1220MSA-170	Gear Box Assembly		1
171	J-5512271	Motor	3HP 230/460V 3PH	1
172	5512272	Key, Dbl Rd Hd	8x8x40 mm	1
173	5512273	Key, Dbl Rd Hd	7x7x45 mm	1
174	J-5512274G	Support Bracket Seat		1
175	TS-2361081	Lock Washer	M8	3
176	5512275	Drive Belt	1922V338	1
177	TS-1490021	Hex Cap Screw	M8-1.25x16	3
178	J-5512277	Variable Speed Assembly		1
179	HBS1220MSA-179	Special Knob	3/8"	1
180	5512279	Special Flat Washer		1
181	J-5512280	Pulley Cover		1
182	J-5512281	Gear Box Pulley		1
183	5512282	Shaft		1
184	J-5512283	Variable Speed Plate		1
185	5512284	Plate		2
186	TS-1550061	Flat Washer	M8	3
189-1	TS-1504031	Socket Head Cap Screw	M8-1.25x16	1
189-2	TS-2361081	Lock Washer	M8	1
189-3	TS-1550061	Flat Washer	M8	1
190	J-5512285	Bow Assembly		1
191	TS-2361101	Lock Washer	M10	4
192	TS-149105	Hex Cap Screw	M10-1.5x35	4
193	5512288	Hose	30mm	1
194	TS-1492031	Hex Cap Screw	M12-1.75x35	4
195	TS-2361121	Lock Washer	M12	4
196	5512291	Flexible Nozzle		1
199	5512294	Rubber Stop		2
200	TS-0561051	Hex Nut	1/2"-13	1
201	5512296	Hose Clamp		2
202	J-5512297G	Blade Bracket (Left)		1
203	TS-2360121	Flat Washer	M12	4
204	TS-1492021	Hex Cap Screw	M12-1.75x30	4
205	TS-1482021	Hex Cap Screw	M6-1.0x12	2
206	TS-2361061	Lock Washer	M6	2
207	J-5512302G	Blade Bracket (Right)		1

Index No	Part No	Description	Size	Qty
208	TS-1550061	Flat Washer	M8	11
209	TS-2361081	Lock Washer	M8	6
210	5512304	Wire Brush Seat		1
211	5512680	Wire Brush		1
212	TS-2361061	Lock Washer	M6	1
213	5512107	Blade	1" x 0.035" x 156" 4/6VT	1
	5512108	Blade	1" x 0.035" x 156" 6/10VT	1
214	TS-1505071	Socket Head Cap Screw	M10-1.5x45	4
215	TS-2361101	Lock Washer	M10	4
216	TS-1550071	Flat Washer	M10	4
217	TS-1550041	Flat Washer	M6	1
218	TS-1482011	Hex Cap Screw	M6-1.0x10	1
219	TS-1490021	Hex Cap Screw	M8-1.25x16	2
220	TS-1524021	Set Screw	M8-1.25x10	4
221	HBS1220MSA-221	Adjustable Mount Bracket (Right)		1
222	HBS1220MSA-222	Adjustable Mount Bracket (Left)		1
223	5512317	Lock Block		2
224	TS-1524031	Socket Set Screw	M8-1.25x12	8
225	HBS1220MSA-225	Special Knob	3/8"-16	2
226	TS-1550071	Flat Washer	M10	2
227	HBS1220MSA-227	Scale		1
228	F009884	Socket Head Button Screw	M5-0.8x8	4
229	TS-1505031	Socket Head Cap Screw	M10-1.5x25	2
230	J-5512324G	Slide Bracket		1
231	J-5512325	Idler Wheel		1
232	BB-6206ZZ	Ball Bearing	6206ZZ	3
233	5512327	Special Washer	M12-1.75x35	1
234	TS-1492011	Hex Cap Screw	M12-1.75x25	4
235	HBS1220MSA-235	Blade Guard		1
236	5512330	Guide Bracket (Left)		1
237	TS-1504061	Socket Head Cap Screw	M8-1.25x30	1
238	BB-6208ZZ	Ball Bearing	6208ZZ	4
239	TS-1503041	Socket Head Cap Screw	M6-1.0x16	4
240	5512684	Rear Blade Guide, Left		1
241	5512683	Front Blade Guide, Left		1
242	5512678	Eccentric Shaft Assembly		2
242A	TS-1504081	Socket Head Cap Screw	M8-1.25x40	4
242B	BB-6201ZZ	Ball Bearing	6201ZZ	8
242C	5517141	Eccentric Shaft Bushing		2
243	5512340	Shaft		2
244	5512341	Spring		2
245	5512342	Adjusting Knob		2
246	J-5512343	Drive Wheel		1
247	5512344	Special Washer	M12-1.75x50	1
248	F009532	Hex Cap Screw	M12-1.75x20	1
249	5512346	Guide Bracket (Right)		1
250	5517140	Center Shaft Bushing		2
251	5512686	Rear Blade Guide, Right		1
252	5512685	Front Blade Guide, Right		1
253	J-5512350G	Blade Wheel Cover		1
254	TS-1503031	Socket Head Cap Screw	M6-1.0x12	4
255	TS-1482021	Hex Cap Screw	M6-1.0x12	2
256	TS-2361061	Lock Washer	M6	2
257	TS-1550041	Flat Washer	M6	2
258	HBS1220MSA-258	Handle		2
259	HBS1220MSA-259	Wire Brush Guard		1
260	F000297	Phillips Pan HD Mach Screw	1/4"-20x3/8"	6
261	5517143	Center Shaft Assembly		2
274	HBS1220MSA-274	Hose Clamp		1
275	HBS1220MSA-275	Hose		1
276	HBS1220MSA-276	Copper Tube		2
277	TS-1490081	Hex Cap Screw	M8-1.25x45	4

Index No	Part No	Description	Size	Qty
278	TS-1540061	Hex Nut	M8-1.25	4
279	HBS1220MSA-279	Bracket		1
280	TS-0680041	Flat Washer	3/8"	1
281	HBS1220MSA-281	Special Washer		1
282	F014010	Key, Dbl Rd Hd	12x8x30 mm	1
283	LM000320	Motor Label, HBS-1220MSA		1
284	JET-203	JET Logo	203x84mm	1
286	HBS1220MSA-286	Block		4
286-1	TS-1490031	Hex Cap Screw	M8-1.25x20	4
287	5521936	Bushing	3mm	1
288	TS-0561051	Hex Nut	1/2"-13	1
289	HBS1220MSA-289	Rubber Stop Holder		1
290	HBS1220MSA-290	Rubber Clamp	ACC-3.5	2
291	TS-2361121	Lock Washer	M12	4
292	HBS1220MSA-292	Rubber Clamp	ACC-2.5	2
293	HBS1220MSA-293	Special Knob	3/8"	4
294	TS-1525031	Socket Set Screw	M10-1.5x16	4
295	HBS1220MSA-295	Bracket		1
296	HBS1220MSA-296	Blade Break Sensor		1
297	WB25-808	Socket Head Button Screw	M4-0.7x7	2
298	HBS1220MSA-298	Wire Clamp		1
299	LM000321	Speed Chart, HBS-1220MSA		1

14.3.1 HBS-1220MSA/MSAH Control Box Assembly – Exploded View

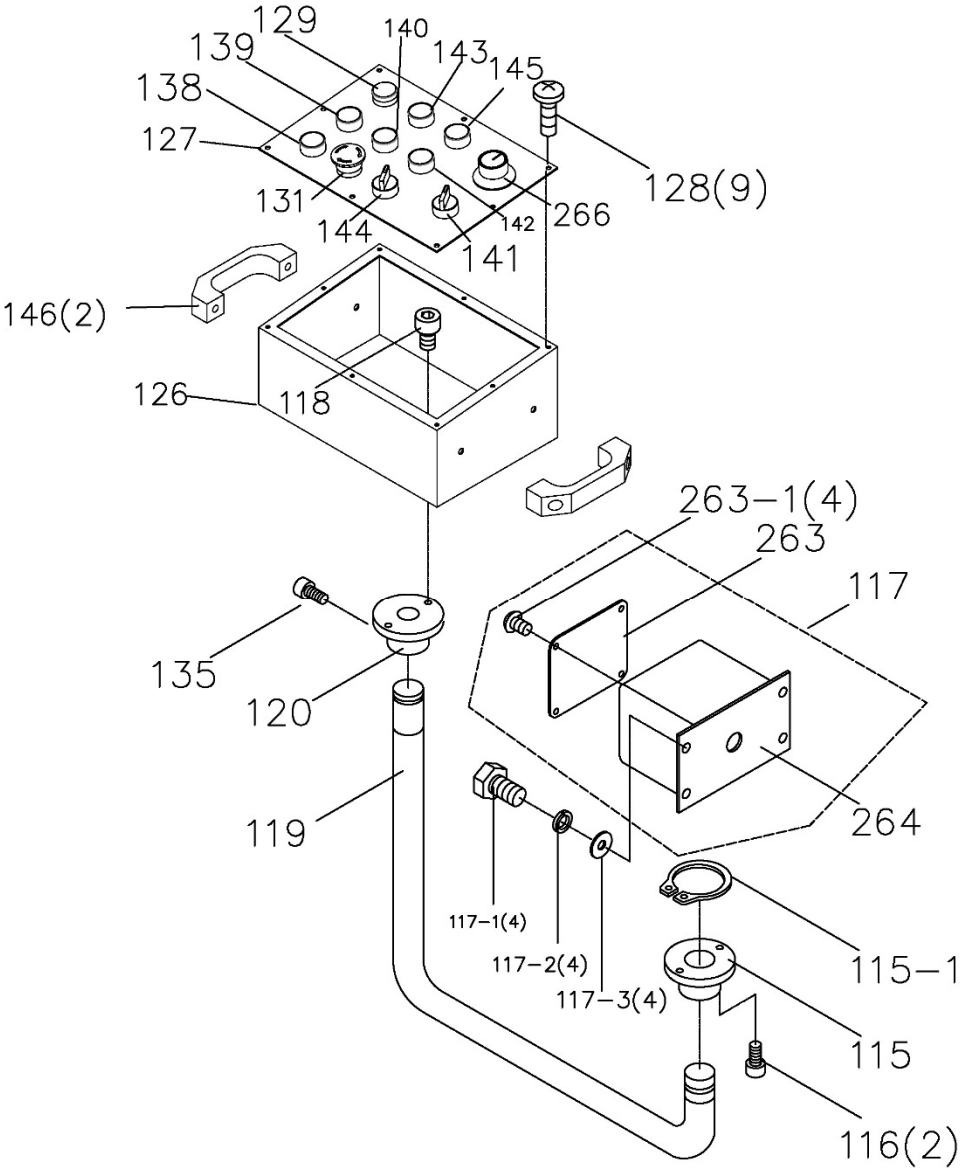

14.3.2 HBS-1220MSA/MSAH Control Box Assembly – Parts List

Index No	Part No	Description	Size	Qty
115	HBS1220MSA-115	Swivel Bushing		1
115-1	F006089	C-Retaining Ring, Ext	S-48	1
116	TS-0207031	Socket Head Cap Screw	1/4"-20x5/8"	2
117	HBS1220MSA-117	Stationary Box Assembly		1
117-1	TS-1490021	Hex Cap Screw	M8-1.25 x 16	4
117-2	TS-2361081	Lock Washer	M8	4
117-3	TS-1550061	Flat Washer	M8	4
118	TS-0207091	Socket Head Cap Screw	1/4"-20 x 3/4"	2
119	HBS1220MSA-119	Control Column		1
120	HBS1220MSA-120	Swivel Block		1
126	HBS1220MSA-126	Control Box		1
127	HBS1220MSA-127	Control Panel		1
	HBS1220MSAH-127	Control Panel (Hydr Vise)	for Hydraulic vise	1
128	F009884	Socket Head Button Screw	M5-0.8x8	9
129	5512681	Power Indicator Light		1
131	5512682	Emergency Stop Switch		1
135	HBS1220MSAH-135	Adjusting Screw	1/4"x5/8"	1
138	5512237	Stop Switch		1
139	5512238	Start Switch		1
140	5512216	Push Button (Saw Head Down)		1
141	HBS1220MSAH-141	Manual/Auto Switch		1
142	HBS1220MSAH-142	Hydraulic Vise Open Switch		1
143	5512215	Push Button (Saw Head Up)		1
144	5512235	Coolant Switch		1
145	HBS1220MSAH-145	Hydraulic Vise Close Switch		1
146	HBS1220MSA-146	Handle		2
263	HBS1220MSA-263	Box Cover		1
263-1	F009884	Socket Head Button Screw	M5-0.8x8	4
264	HBS1220MSA-264	Connection Box		1
266	HBS1220MSA-266	Hydraulic Cylinder Dial		1

14.4.1 HBS-1220MSA/MSAH Electrical Box Assembly – Exploded View

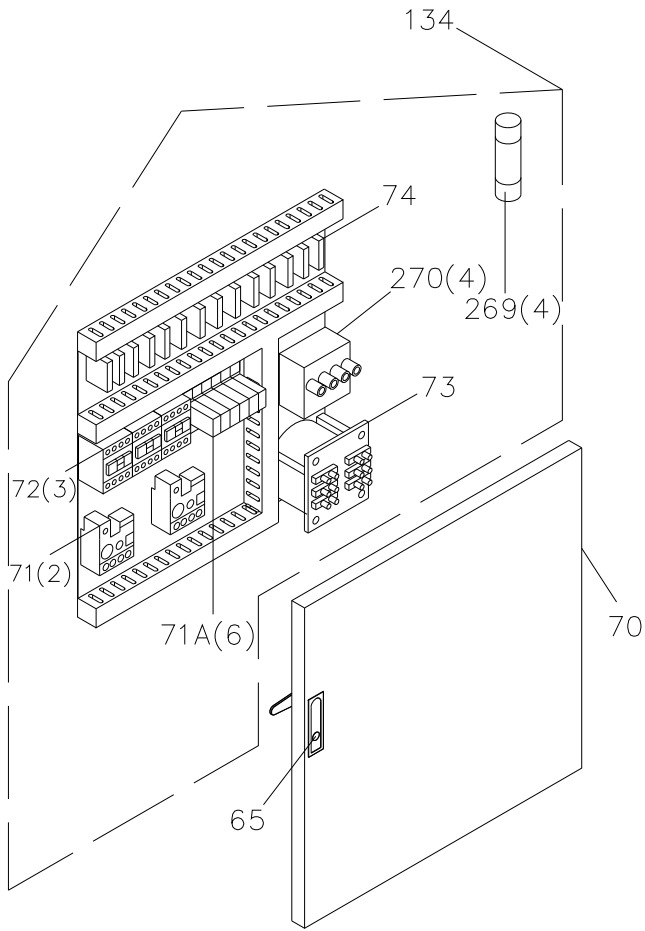

14.4.2 HBS-1220MSA/MSAH Electrical Box Assembly – Parts List

Index No	Part No	Description	Size	Qty
65	HBS1220MSA-65	Keyed Door Latch		1
70	HBS1220MSA-70	Electric Box Door Cover		1
71	HBS1220MSA-OMM230	Overload for Main Motor	7.2-10A (230V)	1
	HBS1220MSA-OMM460	Overload for Main Motor	3.5-4.8A (460V)	1
	HBS1220MSA-OOP230	Overload for Oil Pump	1.4-2A (230V)	1
	HBS1220MSA-OOP460	Overload for Oil Pump	0.75-1 A (460V)	1
71A	RU4S-C-A110	Relay	2pcs MSA, 4pcs MSAH	2/4
	RJ2S-CL-A110	Relay		2
72	HBS1220MSA-72	Motor Contactor	CU-11	3
73	HBS1220MSA-73	Transformer	150VA 230/460/110V	1
74	262-301	Power Circuit Terminal Block	Left Side	1
	261-301	Power Circuit Terminal Block	Right Side	1
134	HBS1220MSA-134	Electric Panel Complete		1
	HBS1220MSAH-134	Electric Panel Complete		1
269	HBS1220MSA-FU2A	Fuse	2A (230V input)	2
	HBS1220MSA-FU1.5A	Fuse	1.5A (230V output)	2
	HBS1220MSA-FU1A	Fuse	1A (460V input)	2
	HBS1220MSA-FU1.5A	Fuse	1.5A (460V output)	2
270	HBS1220MSA-270	Fuse Bracket		4