

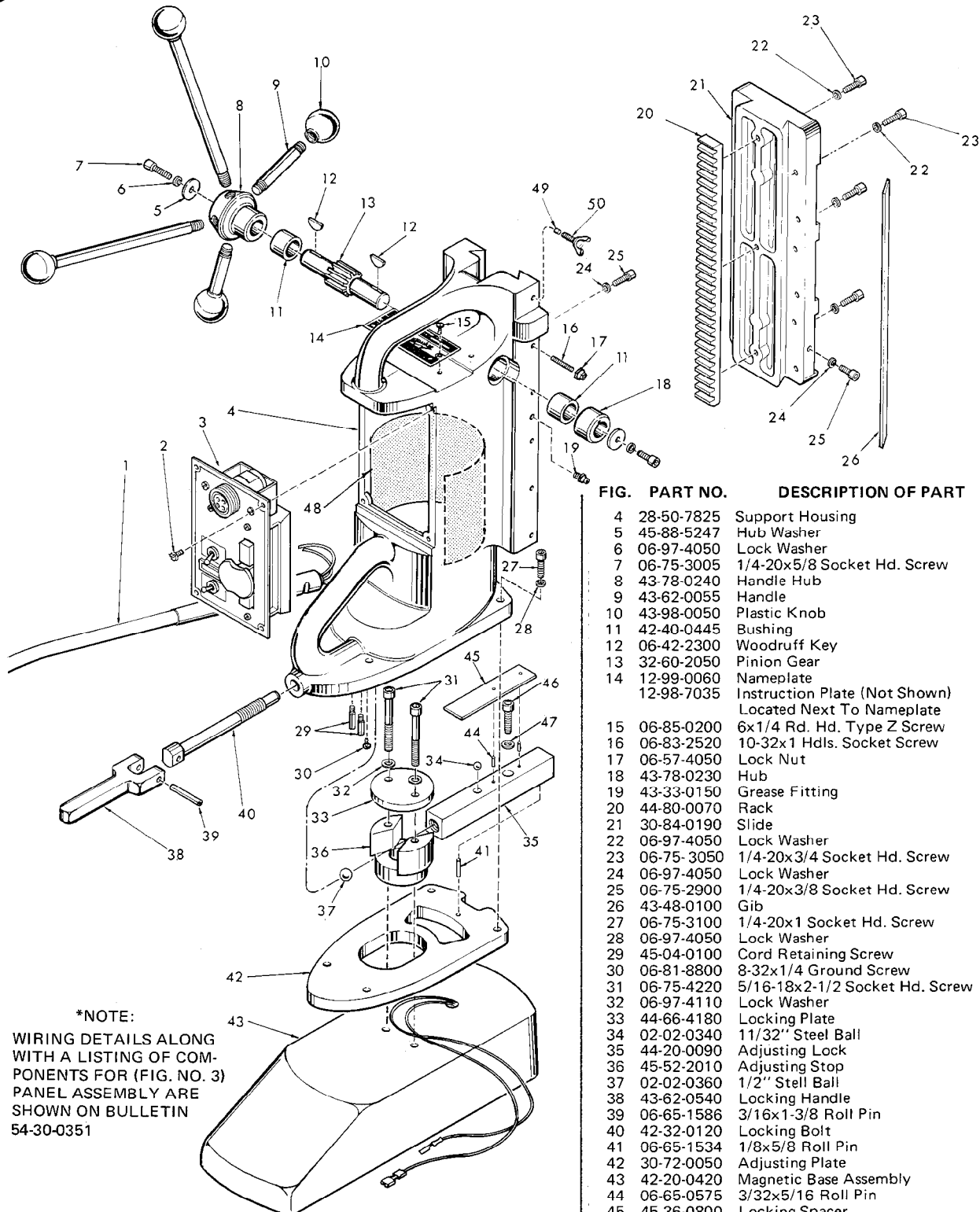

SERVICE PARTS LIST

BULLETIN NO.
54-46-2404

SPECIFY CATALOG NO. AND SERIAL NO. WHEN ORDERING PARTS		REVISED BULLETIN 54-46-2403	DATE Sept. '86
ADJUSTABLE BASE ELECTROMAG DRILL STAND			
CATALOG NO. 4231	STARTING SERIAL NO. 500-15800	WIRING INSTRUCTION * SEE NOTE	



***NOTE:**
WIRING DETAILS ALONG WITH A LISTING OF COMPONENTS FOR (FIG. NO. 3) PANEL ASSEMBLY ARE SHOWN ON BULLETIN 54-30-0351

FIG.	PART NO.	DESCRIPTION OF PART	NO. REQ.
	4	28-50-7825 Support Housing	(1)
	5	45-88-5247 Hub Washer	(2)
	6	06-97-4050 Lock Washer	(2)
	7	06-75-3005 1/4-20x5/8 Socket Hd. Screw	(2)
	8	43-78-0240 Handle Hub	(1)
	9	43-62-0055 Handle	(4)
	10	43-98-0050 Plastic Knob	(4)
	11	42-40-0445 Bushing	(2)
	12	06-42-2300 Woodruff Key	(2)
	13	32-60-2050 Pinion Gear	(1)
	14	12-99-0060 Nameplate	(1)
		12-98-7035 Instruction Plate (Not Shown) Located Next To Nameplate	(1)
	15	06-85-0200 6x1/4 Rd. Hd. Type Z Screw	(4)
	16	06-83-2520 10-32x1 Hdls. Socket Screw	(6)
	17	06-57-4050 Lock Nut	(6)
	18	43-78-0230 Hub	(1)
	19	43-33-0150 Grease Fitting	(2)
	20	44-80-0070 Rack	(1)
	21	30-84-0190 Slide	(1)
	22	06-97-4050 Lock Washer	(7)
	23	06-75-3050 1/4-20x3/4 Socket Hd. Screw	(7)
	24	06-97-4050 Lock Washer	(2)
	25	06-75-2900 1/4-20x3/8 Socket Hd. Screw	(2)
	26	43-48-0100 Gib	(1)
	27	06-75-3100 1/4-20x1 Socket Hd. Screw	(4)
	28	06-97-4050 Lock Washer	(4)
	29	45-04-0100 Cord Retaining Screw	(2)
	30	06-81-8800 8-32x1/4 Ground Screw	(1)
	31	06-75-4220 5/16-18x2-1/2 Socket Hd. Screw	(2)
	32	06-97-4110 Lock Washer	(2)
	33	44-66-4180 Locking Plate	(1)
	34	02-02-0340 11/32" Steel Ball	(1)
	35	44-20-0090 Adjusting Lock	(1)
	36	45-52-2010 Adjusting Stop	(1)
	37	02-02-0360 1/2" Steel Ball	(1)
	38	43-62-0540 Locking Handle	(1)
	39	06-65-1586 3/16x1-3/8 Roll Pin	(1)
	40	42-32-0120 Locking Bolt	(1)
	41	06-65-1534 1/8x5/8 Roll Pin	(1)
	42	30-72-0050 Adjusting Plate	(1)
	43	42-20-0420 Magnetic Base Assembly	(1)
	44	06-65-0575 3/32x5/16 Roll Pin	(2)
	45	45-36-0800 Locking Spacer	(1)
	46	06-75-3975 5/16-18x1 Socket Hd. Screw	(1)
	47	06-97-4110 Lock Washer	(1)
	48	23-16-0760 Panel Insulator	(1)
	49	45-30-0160 Brass Slug	(1)
	50	06-88-0110 1/4-20x3/4" Wing Screw	(1)

FIG.	PART NO.	DESCRIPTION OF PART	NO. REQ.
1	22-64-0075	Cord Set	(1)
2	06-81-5400	8-32x5/16 Binder Sems	(4)
★3	23-35-0301	Panel Assembly (See Note)	(1)