

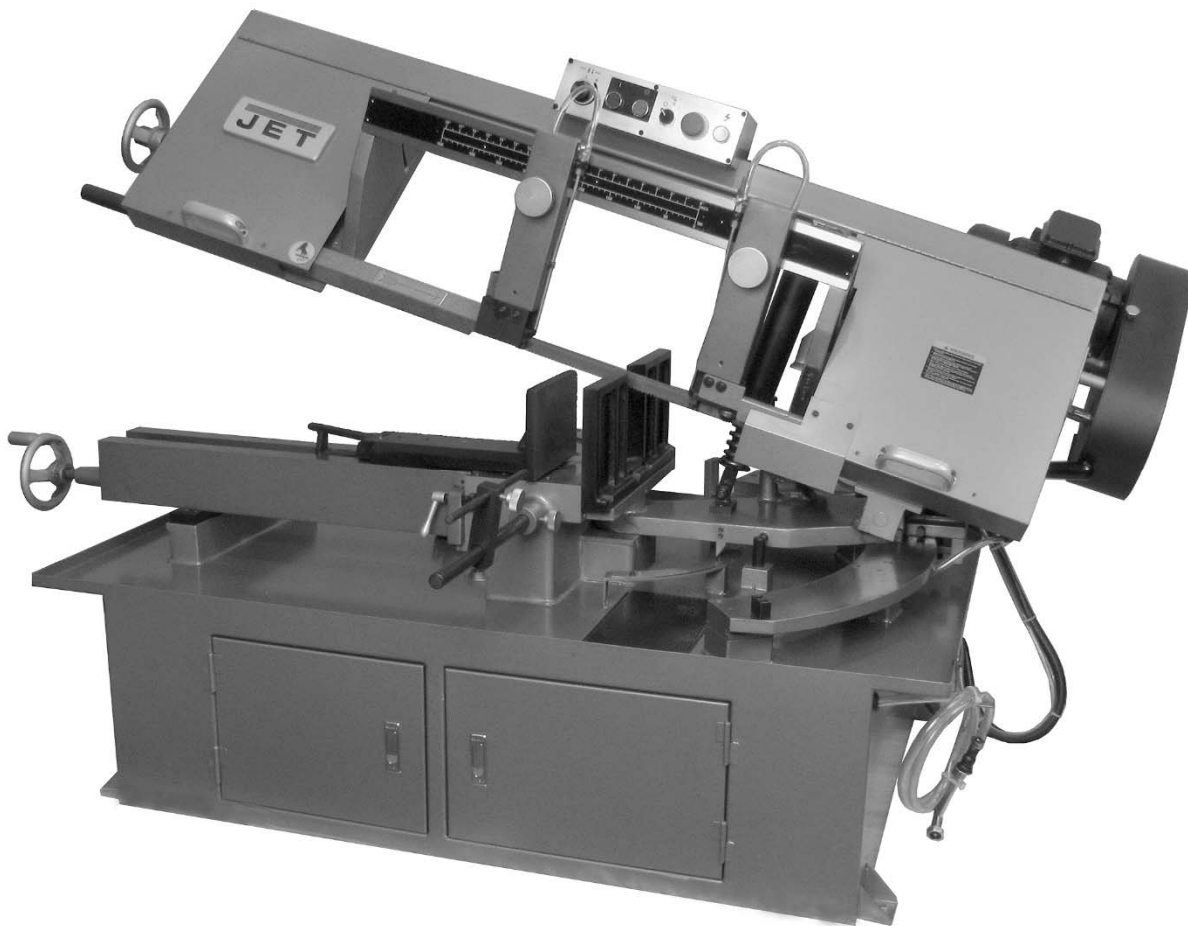

Operating Instructions and Parts Manual Horizontal Dual Mitering Band Saw

Models: MBS-1018-1, MBS-1018-3



JET
427 New Sanford Road
LaVergne, Tennessee 37086
Ph.: 800-274-6848
www.jettools.com

Part No. M-413410
Edition 4 09/2018
Copyright © 2018 JET

12.1.1 MBS-1018-1/MBS-1018-3 Bow Assembly – Exploded View

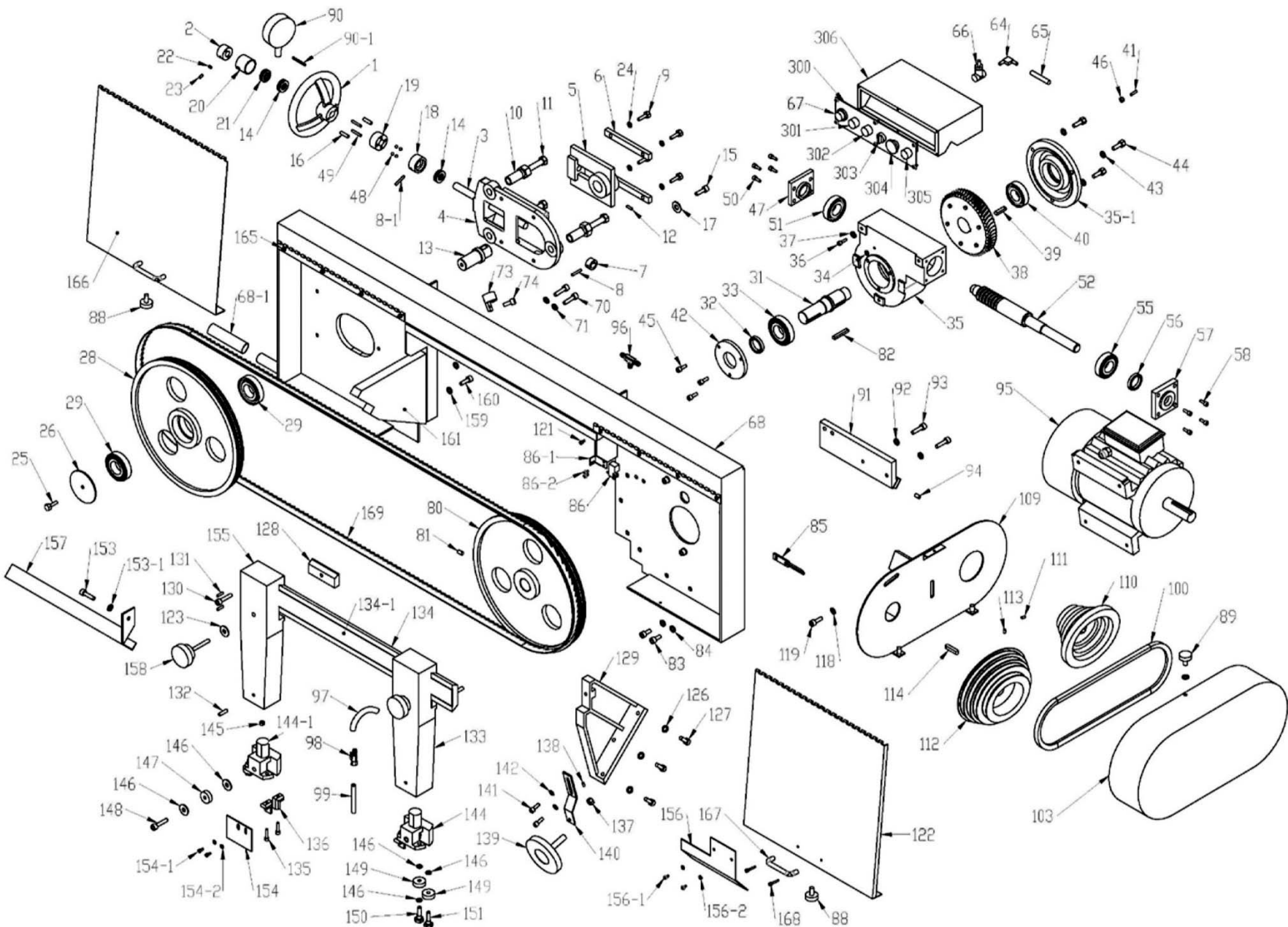

12.1.2 MBS-1018-1/MBS-1018-3 Bow Assembly – Parts List

Index No	Part No	Description	Size	Qty
1	EHB916V-249	Handwheel		1
2	EHB916V-20	Lock Nut		1
3	EHB916V-03	Shaft		1
4	MBS-1018-1-4	Bracket		1
5	MBS-1018-1-5	Slide		1
6	MBS-1018-1-6	Gib		2
7	EHB916V-07	Collar		1
8	F012076	Roll pin	M5x30	2
8-1	F012077	Roll pin	M5x40	1
9	TS-0081031	Hex Cap Screw	5/16x3/4	4
10	EHB916V-10	Adjusting Screw	3/4x1-1/2	1
11	TS-0060111	Hex Cap Screw	3/8x2-1/2	1
12	TS-0271031	Set Screw	3/8"x3/8"	1
13	EHB916V-13	Spindle		1
14	BB-51103	Thrust bearing	511003	2
15	TS-0060061	Hex Cap Screw	3/8x1-1/4	1
16	F012076	Roll pin	M5x30	1
17	TS-0732061	Lock Washer	3/8"	1
18	EHB916V-18	Driven		1
19	EHB916V-19	Thrust Bearing Housing		1
20	EHB916V-02	Collar		1
21	EHB916V-21	Disc Spring		6
22	EHB916V-22	Copper		1
23	TS-0267041	Set Screw	1/4"x3/8"	1
24	TS-0720081	Lock Washer	5/16"	1
25	TS-0060051	Hex Cap Screw	3/8"x1"	1
26	EHB916V-26	Special Washer		1
28	MBS-1018-1-28	Wheel LH		1
29	BB-6306ZZ	Bearing	6306ZZ	2
	MBS-1018-GBA	Gear Box Assembly (includes #31-47,50-58,82)		1
31	EHB916V-31	Output Shaft		1
32	EHB916V-32	Oil Seal	32.42.7	1
33	BB-30207	Bearing	30207	1
34	EHB916V-34	Oil Plug	1/4"	1
35	MBS-1018-1-35	Gear Box Housing		1
35-1	MBS-1018-1-35-1	Cover		1
36	TS-0060031	Hex Cap Screw	3/8-16x3/4"	3
37	TS-0732061	Lock Washer	3/8"	3
38	EHB916V-38	Worm Gear		1
39	EHB916V-39	Key	7x7x35 mm	1
40	BB-30206	Bearing	30206	1
41	TS-0267121	Set Screw	1/4"x3/4"	3
42	MBS-1018-1-42	Cap		1
43	TS-0732061	Lock Washer	3/8"	3
44	TS-0060071	Hex Cap Screw	3/8"-16x1-1/2"	3
45	TS-0207021	Socket Head Cap Screw	1/4"-20x5/8"	3
46	TS-0561011	Hex Nut	1/4"	3
47	MBS-1018-1-47	Cap		1
48	SB-3/16	Steel Ball	3/16"	2
49	TS-0270061	Set Screw	5/16"-18x5/8"	1
50	TS-0207021	Socket Head Cap Screw	1/4"-20x5/8"	4
51	BB-6004	Bearing		1
52	EHB916V-52	Input Shaft		1
55	BB-3205	Bearing	3205	1
56	EHB916V-56	Oil Seal	25.35.7	1
57	MBS-1018-1-57	Cap		1
58	TS-0207021	Socket Head Cap Screw	1/4"-20x5/8"	4
64	MBS-1018-1-64	Fitting		2
65	EHB916V-65	Tubing	5/16"x65"	2

Index No	Part No	Description	Size	Qty
66	EHB916V-66	Valve		1
67	EHB916V-67	Feed Knob		1
68	MBS1018-1-68	Bow Frame		1
68-1	MBS1018-1-68-1	Handle Grip		1
70	TS-0081031	Hex Cap Screw	5/16"x3/4"	2
71	TS-0680031	Flat Washer	5/16"	2
73	EHB916V-73	Tube Retainer		2
74	EHB916V-74	Round Head Screw	3/16"x3/8"	2
80	MBS-1018-1-80	Drive Wheel		1
81	TS-0271032	Socket Set Screw	3/8-24x3/8"	1
82	EHB916V-82	Key	7x7x40 mm	1
83	TS-0081031	Hex Cap Screw	5/16-18x3/4"	2
84	TS-0720081	Lock Washer	5/16"	2
85	EHB916V-85	Bracket		1
86	EHB916V-86	Sensor		1
86-1	EHB916V-86-1	Sensor Seat		1
86-2	EHB916V-86-2	Screw	3/16x3/8"	1
88	EHB916V-88	Knob		2
89	EHB916V-88	Knob		1
90	EHB916V-90	Blade Tension Gauge		1
90-1	EHB916V-90-1	Pin		1
91	MBS-1018-1-91	Front Pivot Bracket		1
92	TS-0732061	Lock Washer	3/8"	3
93	TS-0060081	Hex Cap Screw	3/8-16x3/4"	3
94	TS-0271051	Socket Set Screw	3/8-16x1/2"	1
95	EHB1018V-95	Motor	2HP,230V,1PH	1
	EHB1018V-95RC	Run Capacitor (for MBS-1018-1)	40µF 350VAC	1
	EHB1018V-95SC	Start Capacitor (for MBS-1018-1)	600µF 125VAC	1
	EHB1018V-95MFC	Motor Fan Cover		1
	EHB1018V-95MF	Motor Fan		1
	EHB1018V-95MJB	Motor Junction Box		1
	EHB1018VM-95	Motor	2HP,230/460V,3PH	1
	EHB1018VM-95MFC	Motor Fan Cover		1
	EHB1018VM-95MF	Motor Fan		1
	EHB1018VM-95MJB	Motor Junction Box		1
96	EHB916V-96	3 Way Coolant Block		1
97	EHB916V-97	Hose		2
98	EHB916V-98	Valve		2
99	EHB916V-99	Hose Clamp		2
100	VB-A36	Belt	A-36	1
103	MBS1018-1-103	Upper Guard		1
109	MBS1018-1-109	Lower Guard		1
110	MBS1018-1-110	Motor Pulley		1
111	TS-0270021	Socket Set Screw	5/16-18x5/16"	1
112	MBS1018-1-112	Gear Box Pulley		1
113	TS-0270021	Socket Set Screw	5/16-18x5/16"	1
114	EHB916V-114	Key	5x5x40 mm	1
118	TS-0720081	Lock Washer	5/16"	2
119	EHB916V-119	Hex Head Screw	5/16"-20x3/4"	2
121	EHB916V-121	Round Head Screw	#10-3/16x3/8"	4
122	MBS1018-1-122	Cover R.H		1
123	TS-0680041	Lock Washer	3/8"	4
126	TS-0680041	Lock Washer	3/8"	3
127	TS-0060031	Hex Cap Screw	3/8x16x3/4"	3
128	EHB1018V-128	Stationary Plate		2
129	MBS1018-1-129	Bracket		1
130	TS-0209061	Socket HD Cap Screw	3/8"-16x1-1/4"	2
131	TS-0267071	Set Screw	1/4"-20x3/4"	4
132	TS-0270061	Set Screw	5/16"-18x5/8"	1
133	MBS-1018-1-133	Bracket RH		4
134	EHB1018VM-134	Slide		1
134-1	MBS1018-1-134-1	Scale		1

Index No	Part No	Description	Size	Qty
135	EHB916V-135	Screw	3/16"-24x7/8"	4
136	EHB916V-136	Carbide Guide		4
137	EHB1018V-137	Collar		2
138	TS-0267021	Set Screw	1/4"x1/4"	2
139	EHB916V-139	Wire Brush		1
140	EHB1018V-140	Brush Holder		1
141	TS-0207021	Socket Head Cap Screw	1/4"x20x5/8"	2
142	TS-0680021	Flat Washer	1/4"x19x2.0	2
144	EHB916V-144	Guide, Right		1
144-1	EHB916V-144-1	Guide, Left		1
145	TS-0561021	Hex Nut	5/16"-18T	2
146	TS-0680041	Flat Washer	3/8"	4
147	BB-6200ZZ	Bearing	6200ZZ	1
148	EHB916V-148	Special Screw	10x30 mm	1
149	BB-6200ZZ	Bearing	6200ZZ	2
150	EHB916V-150	Special Screw		1
151	EHB916V-151	Special Screw		1
153	TS-0207031	Socket Head Cap Screw	1/4"-20 x 5/8"	1
153-1	TS-0680021	Flat Washer	1/4"	1
154	EHB916V-154	Guide Cover		1
154-1	EHB916V-154-1	Hex Cap Screw	3/16 x 3/8"	2
154-2	F002633	Flat Washer	3/16"	2
155	MBS-1018-1-155	Bracket LH		4
156	EHB916V-156	Blade Cover		1
156-1	EHB916V-156-1	Screw	3/16 x 3/8"	2
156-2	F002633	Flat Washer	3/16"	2
157	MBS1018-1-157	Blade Cover		1
158	EHB916V-158	Special Knob		2
159	TS-0680041	Flat Washer	3/8"	1
160	TS-0060031	Hex Head Screw	3/8x16x3/4"	3
161	MBS1018-1-161	Bracket		1
165	EHB916V-165	Round Head Screw	3/16x3/8"	4
166	MBS1018-1-166	Cover LH		1
167	EHB916V-167	Handle		2
168	TS-081F051	Phillips Screw	1/4"-20x3/4"	4
169	414405	Blade	1"x0.032"x144" (4/6T HSS)	1
	414407	Blade	1"x0.032"x144" (4/6T)	1
300	MBS1018-1-300	Control panel		1
301	EHB916V-301	Start Switch, Green		1
302	EHB1018VM-302	Stop Switch, Red		1
303	EHB916V-303	Selection Switch		1
304	EHB1018VM-304	Emergency Stop		1
305	EHB916V-305	Power Indicator Light		1
306	MBS1018-1-306	Control Box		1
	LM000250	Warning Label (not shown)	4" x 3"	1
	JET-203	JET Logo (not shown)	203 x 84mm	1

12.2.1 MBS-1018-1/MBS-1018-3 Base Assembly – Exploded View

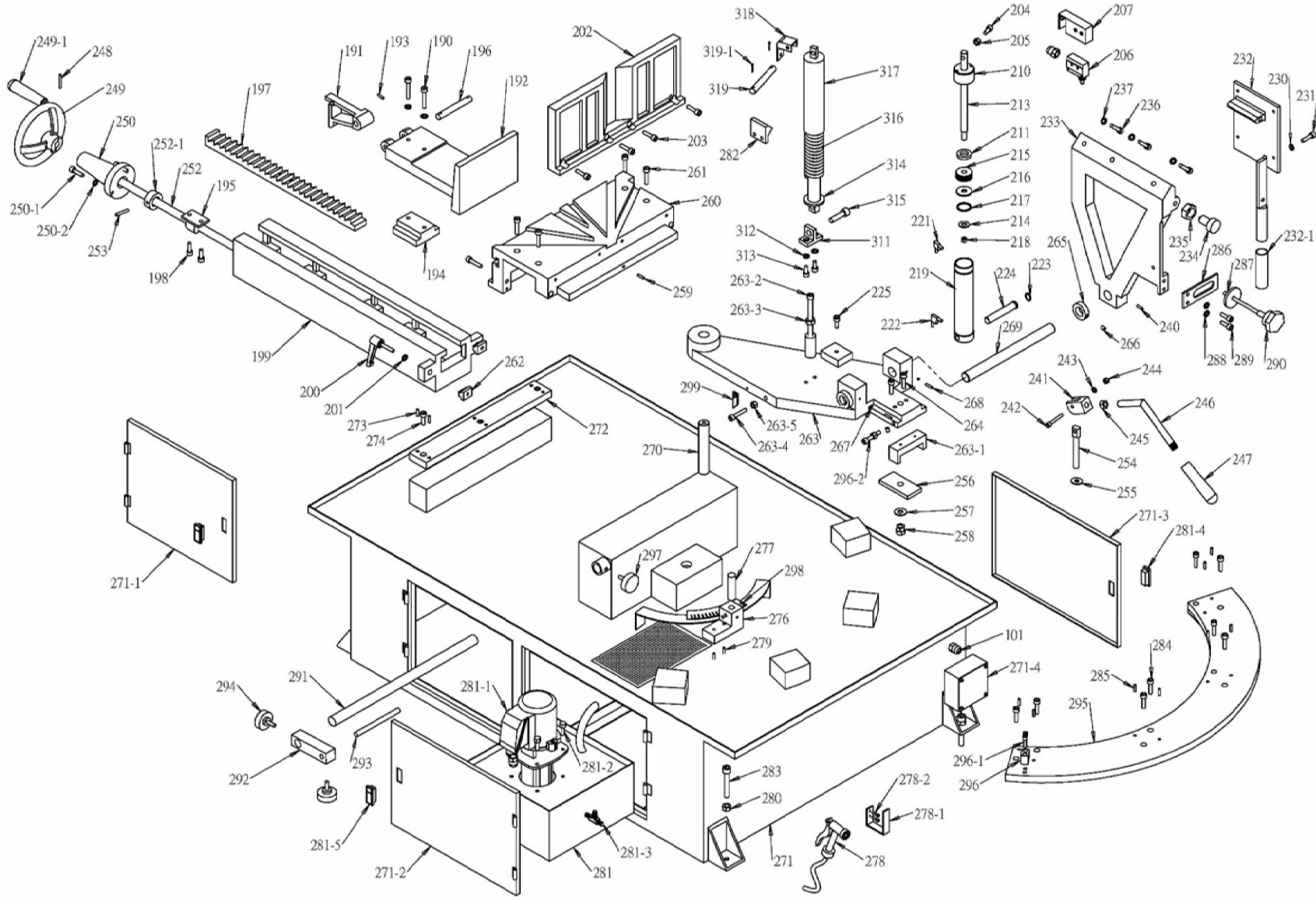

12.2.2 MBS-1018-1/MBS-1018-3 Base Assembly – Parts List

Index No	Part No	Description	Size	Qty
101	EHB916V-101	Cable Gland	PG-11	1
190	TS-0060071	Hex Cap Screw	3/8x1-1/2"	2
191	MBS-1018-1-191	Rack Block		1
192	MBS-1018-1-192	Floating Vise Jaw		1
193	TS-0267041	Set Screw	1/4-20x3/8"	1
194	EHB1018VM-194	Rack Block		1
195	MBS-1018-1-195	Acme Nut Assembly		1
196	EHB1018VM-196	Fixed Pin		1
197	MBS-1018-1-197	Rack		1
198	TS-0081031	Hex Cap Screw	5/16-18x3/4"	2
199	MBS-1018-1-199	Moveable Bed		1
200	EHB1018VM-200	Adjustable Handle		2
201	TS-0680041	Flat Washer	3/8"	1
202	MBS-1018-1-202	Fixed Vise Jaw		1
203	TS-0051061	Hex Cap Screw	5/16"-18x1-1/4"	4
204	TS-0060081	Hex Cap Screw	3/8-16x1-3/4"	1
205	TS-0561031	Hex Nut	3/8"	1
206	EHB916V-206	Limit Switch		1
207	MBS1018-1-207	Limit Switch Seat		1
	EHB916V-OHCA	Oil Hydraulic Cylinder Assembly (includes #210-222)		1
210	EHB916V-210	Cap		1
211	EHB916V-211	Oil Seal	20.35.7	1
213	EHB1018VM-213	Rod		1
214	TS-0680031	Flat Washer	5/16"	1
215	EHB916V-215	Piston		1
216	EHB916V-216	Seal		1
217	EHB916V-217	"O" Ring		1
218	TS-0561021	Hex Nut	5/16"x18T	2
219	EHB916V-219	Tube Assembly		1
221	MBS-1018-1-221	Tube Fitting		1
222	MBS-1018-1-222	Tube Fitting		1
223	EHB916V-223	Ext. Retaining Ring	S-17	1
224	EHB1018VM-224	Pivot Shaft		1
225	EHB916V-225	Socket Set Screw	3/8"-16Tx3/8"	1
230	TS-0680031	Flat Washer	5/16"	4
231	TS-0051051	Hex Cap Screw	5/16x1"	4
232	MBS1018-1-232	Motor Plate		1
232-1	MBS1018-1-232-1	Handle Grip		1
233	MBS-1018-1-233	Rear Pivot Bracket		1
234	TS-0271031	Adjusting Screw	1/2"x2"	2
235	EHB916V-235	Hex Nut	1/2"-12	2
236	EHB916V-236	Hex Head Screw	3/8"-16Tx1-3/4"	3
237	TS-0680041	Flat Washer	3/8"	3
240	TS-0271051	Set Screw	3/8"-16x1/2"	1
241	EHB1018VM-241	Eccentric		1
242	TS-0051011	Hex Cap Screw	5/16x1-3/4"	1
243	TS-0680031	Flat Washer	5/16"	1
244	TS-0561021	Hex Nut	5/16x18T	1
245	TS-0561071	Hex Nut	5/8"	1
246	MBS1018-1-246	Shaft		1
247	MBS1018-1-247	Handle		1
248	EHB916V-248	Roll Pin	1/4x1/2"	1
249	EHB916V-249	Hand Wheel		1
249-1	EHB916V-249-1	Handle		1
250	MBS-1018-1-250	Seat		1
250-1	TS-0051051	Hex Cap Screw	5/16"-18x1"	2
250-2	TS-0720081	Lock Washer	5/16"	2
252	EHB1018VM-252	Acme Screw		1
252-1	EHB916V-252-1	Collar		1
253	EHB916V-253	Roll Pin	6x30 mm	1

Index No	Part No	Description	Size	Qty
254	EHB1018VM-254	Locking Screw		1
255	EHB1018VM-255	Special Washer		1
256	EHB1018VM-256	Locking Piece		1
257	TS-0680061	Flat Washer	1/2"	1
258	TS-0561051	Hex Nut	1/2"-12	2
259	TS-0267121	Socket Set Screw	1/4x3/4"	1
260	MBS-1018-1-260	Table		1
261	TS-0051051	Hex Cap Screw	5/16"x1"	4
262	EHB1018VM-262	Block		1
263	MBS-1018-1-263	Swiveling Seat		1
263-1	MBS-1018-1-263-1	Support Seat		1
263-2	TS-0070161	Hex Cap Screw	1/2x5-1/2"	1
263-3	TS-0640111	Hex Nut	1/2"	1
263-4	TS-0060071	Hex Cap Screw	3/8x1-1/2"	1
263-5	TS-0570031	Hex Nut	3/8"-16	1
264	TS-0050031	Hex Cap Screw	1/4"x3/4"	2
265	EHB916V-265	Collar		2
266	TS-0271031	Socket Set Screw	3/8-16Tx3/8"	4
267	EHB916V-267	Copper		2
268	TS-0271031	Socket Set Screw	3/8-16Tx3/8"	2
269	MBS-1018-1-269	Pivot Shaft		1
270	EHB1018VM-270	Spindle		1
271	MBS1018-1-271	Base Assembly		1
271-1	MBS1018-1-271-1	Left Door		1
271-2	MBS1018-1-271-2	Right Door		1
271-3	MBS1018-1-271-3	Rear Door		1
271-4	MBS1018-1-271-4	Wiring Box		1
272	EHB1018VM-272	Sliding Surface		1
273	TS-0267071	Socket Set Screw	1/4-20x3/4"	6
274	TS-0051051	Hex Cap Screw	5/16"-18x1"	3
276	MBS-1018-1-276	Seat		1
277	EHB1018VM-277	Movable Block		1
278	EHB916V-278	Spray Gun Set		1
278-1	EHB916V-278-1	Hook		1
278-2	EHB916V-278-2	Hex Cap Screw		2
279	TS-0051051	Hex Cap Screw	5/16"-18x1"	2
280	TS-0561051	Hex Nut	1/2"-12T	4
281	MBS-1018-1-281	Coolant Tank		1
281-1	EHB1018V-281-1	Coolant Pump	1/8HP,230V,1 PH	1
281-1	EHB1018VM-281-1	Coolant Pump	1/8HP,230V,3 PH	1
281-2	EHB916V-281-2	Pan Head Machine Screw		1
281-3	EHB916V-96	3 Way Coolant Block		1
281-4	MBS1018-1-281-4	Lock with Key		1
281-5	MBS1018-1-281-5	Lock without Key		2
282	MBS-1018-1-282	Bracket		1
283	TS-0070051	Hex Cap Screw	1/2"-12x2"	4
284	TS-0051061	Hex Cap Screw	5/16"x1-1/4"	8
285	TS-0267071	Set Screw	1/4"-20x3/4"	8
286	EHB1018VM-286	Strap		1
287	EHB916V-26	Special Washer		1
288	TS-0680021	Flat Washer	1/4"	2
289	TS-0050031	Hex Cap Screw	1/4"-20x3/4"	2
290	MBS1018-1-290	Knob		1
291	EHB1018V-258	Shaft	7/8"	1
292	EHB1018V-259	Stop Bracket		1
293	EHB1018V-260	Bar		1
294	EHB916V-261	Knob		2
295	MBS-1018-1-295	Arch Seat		1
296	EHB1018VM-296	Support Block		1
296-1	EHB1018VM-296-1	Socket Head Cap Screw		2
296-2	EHB1018VM-296-2	Screw w/Nut		1
297	EHB916V-261	Knob		1

Index No	Part No	Description	Size	Qty
298	EHB1018VM-298	Scale		1
299	EHB1018VM-299	Indicator		1
311	EHB1018VM-311	Acme Lead Screw Seat		1
312	TS-0680031	Flat Washer	5/16"	2
313	TS-0208061	Socket Head Cap Screw	5/16-18x1"	2
314	EHB1018VM-314	Fixing Rod For Spring		1
315	TS-0211071	Socket Head Cap Screw	1/2"x1-1/2"	1
316	EHB1018VM-316	Spring		1
317	EHB1018VM-317	Spring Cover		1
318	EHB1018VM-318	Bracket		1
319	EHB1018VM-319	Spindle		1
319-1	EHB1018VM-319-1	Open Pin	1/8x1"	2
	LM000248	ID/Warning Label, MBS-1018-1 (not shown)		1
	LM000249	ID/Warning Label, MBS-1018-3 (not shown)		1

12.3.1 MBS-1018-1/MBS-1018-3 Electrical Box Assembly – Exploded View

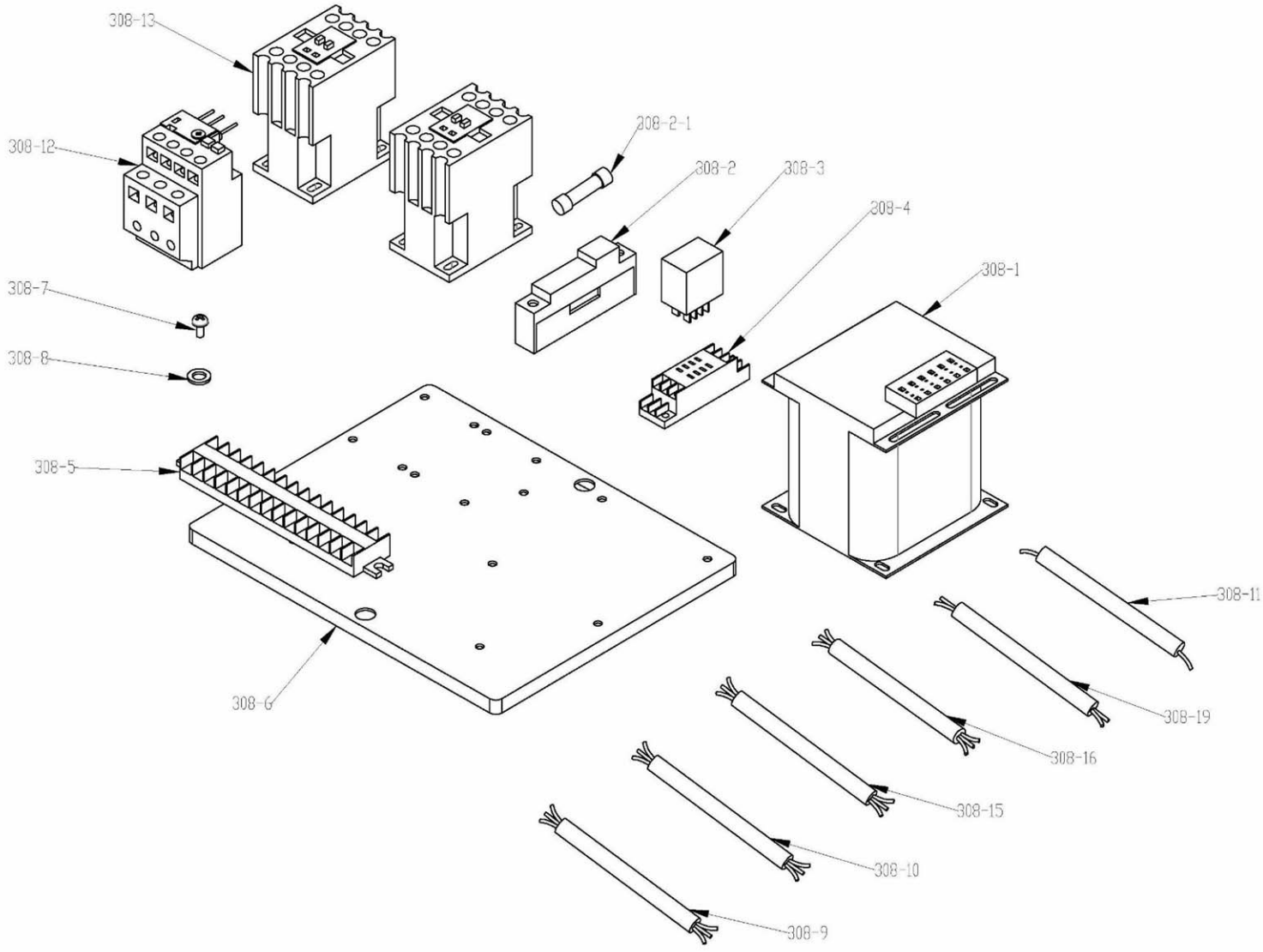

12.3.2 MBS-1018-1 Electrical Box Assembly – Parts List

Index No	Part No	Description	Size	Qty
308-1	EHB916V-308-1	Transformer	115/230/110V	1
308-2	EHB916V-308-2	Fuse Block	32A	1
308-2-1	MBS1018-1-308-2-1	Fuse	3A	1
308-3	EHB916V-308-3	Overload Relay	100/110VAC	1
308-4	EHB916V-308-4	Relay Socket	CT-BMY2	1
308-5	MBS1018-1-308-5	Terminal Block		6
308-6	MBS1018-1-308-6	Electrical Plate		1
308-7	TS-081D022	Phillips Pan Hd Machine Screw	#10-32x3/8"	30
308-8	TS-0680011	Washer	3/16"	30
308-9	MBS1018-1-308-9	Power Cable		1
308-10	MBS1018-1-308-10	Control Cable		1
308-11	MBS1018-1-308-11	Ground Cable	Yellow/Green	1
308-12	EHB1018V-308-12	Overload Relay	11.3-16A	1
308-13	EHB916V-308-13	Magnetic Contactor	CU-11/110V	2
308-15	MBS1018-1-308-15	Motor Cable		1
308-16	MBS1018-1-308-16	Pump Cable		1
308-19	MBS1018-1-308-19	Limit Switch Cable		1

12.3.3 MBS-1018-3 Electrical Box Assembly – Parts List

Index No	Part No	Description	Size	Qty
308-1	EHB1018VM-308-1	Transformer	230/460/12/24/110V	1
308-2	EHB916V-308-2	Fuse Block	32A	1
308-2-1	MBS1018-1-308-2-1	Fuse	3A	1
308-3	MBS1018-1-308-3	Overload Relay	100/110VAC	1
308-4	EHB916V-308-4	Relay Socket	CT-BMY2	1
308-5	MBS1018-1-308-5	Terminal Block		6
308-6	MBS1018-3-308-6	Electrical Plate		1
308-7	TS-081D022	Phillips Pan Hd Machine Screw	#10-32x3/8"	30
308-8	TS-0680011	Washer	3/16"	30
308-9	MBS1018-3-308-9	Power Cable		1
308-10	MBS1018-3-308-10	Control Cable		1
308-11	MBS1018-3-308-11	Ground Cable	Yellow/Green	1
308-12	EHB1018VM-308-12	Overload Relay	5.5-7.5A	1
308-13	EHB1018VM-308-13	Magnetic Contactor	CU-11/110V	2
308-15	MBS1018-3-308-15	Motor Cable		1
308-16	MBS1018-3-308-16	Pump Cable		1
308-19	MBS1018-3-308-19	Limit Switch Cable		1