

## . - F 012 360 000 - 3600

Item	Part Number	Description	Illustration	Price	Quantity	Price Group
1	1 619 PA0 515	Insert	2	-,-	1	-
2	1 619 PA0 092	Pan head screw	1	-,-	25	-
3	1 619 PA0 521	Insert	2	-,-	1	-
4	1 619 PA0 093	Turntable	2	-,-	1	-
5	1 619 PA0 094	Lever Foot	2	-,-	4	-
6	1 619 PA0 095	Plain Washer	2	-,-	4	-
7	1 619 PA0 096	Spring Lock Washer	1	-,-	11	-
8	1 619 PA0 097	Pan head screw	2	-,-	4	-
9	1 619 PA0 098	Pan head screw	2	-,-	2	-
10	1 619 PA0 099	Plate	2	-,-	1	-
11	1 619 PA0 100	Spring Lock Washer	1	-,-	33	-
12	1 619 PA0 352	Pan head screw	2	-,-	4	-
13	1 619 PA0 101	Plate	2	-,-	1	-
14	1 619 PA0 102	Solder Stick	2	-,-	1	-
15	1 619 PA0 103	Bolt	1	-,-	1	-
16	1 619 PA0 104	Flange	1	-,-	1	-
18	1 619 PA0 106	Flange	1	-,-	1	-
20	1 619 PA0 108	Key	1	-,-	1	-
21	1 619 PA0 353	Lever Foot	1	-,-	1	-
22	1 619 PA0 109	Pan head screw	1	-,-	7	-
25	1 619 PA0 112	Pan head screw	1	-,-	4	-
27	1 619 PA0 114	Ring	1	-,-	2	-
28	1 619 PA0 115	Bearing	1	-,-	1	-
29	1 619 PA0 116	Ring	1	-,-	1	-
30	1 619 PA0 117	Pan head screw	1	-,-	4	-
31	1 619 PA0 119	Spring	1	-,-	1	-
32	1 619 PA0 120	Pin	1	-,-	1	-
33	1 619 PA0 121	Case	1	-,-	1	-
34	1 619 PA0 122	Baffle	1	-,-	1	-
35	1 619 PA0 123	Nut	1	-,-	1	-
36	1 619 PA0 124	Spring Lock Washer	1	-,-	1	-
37	1 619 PA0 125	Pinion	1	-,-	1	-
38	1 619 PA0 354	Bearing	1	-,-	1	-

Item	Part Number	Description	Illustration	Price	Quantity	Price Group
39	1 619 PA0 126	Pin	1	-,-	1	-
40	1 619 PA0 127	Armature	1	-,-	1	-
41	1 619 PA0 128	Bearing	1	-,-	1	-
42	1 619 PA0 129	Bearing Sleeve	1	-,-	1	-
43	1 619 PA0 130	Pan head screw	1	-,-	2	-
44	1 619 PA0 131	Cover	1	-,-	1	-
45	1 619 PA0 132	Pan head screw	1	-,-	4	-
46	1 619 PA0 133	Brush Spring	1	-,-	2	-
47	1 619 PA0 134	Brush Holder	1	-,-	2	-
49	1 619 PA0 136	Housing	1	-,-	1	-
50	1 619 PA0 137	Stator	1	-,-	1	-
51	1 619 PA0 138	Plain Washer	1	-,-	19	-
52	1 619 PA0 139	Pan head screw	1	-,-	2	-
53	1 619 PA0 140	Plug	1	-,-	1	-
54	1 619 PA0 141	Cable	1	-,-	1	-
55	1 619 PA0 142	Mains switch	1	-,-	1	-
56	1 619 PA0 143	Pan head screw	1	-,-	7	-
57	1 619 PA0 144	Fastening Clamp	1	-,-	1	-
59	1 619 PA0 146	Mains switch	1	-,-	1	-
60	1 619 PA0 147	Pin	1	-,-	1	-
61	1 619 PA0 148	Linkage	1	-,-	1	-
62	1 619 PA0 149	Mains switch	1	-,-	1	-
63	1 619 PA0 150	Terminal	1	-,-	1	-
65	1 619 PA0 152	Pan head screw	1	-,-	1	-
66	1 619 PA0 153	Pan head screw	1	-,-	1	-
67	1 619 PA0 154	Washer	1	-,-	1	-
68	1 619 PA0 155	Pan head screw	1	-,-	1	-
69	1 619 PA0 156	Cover	1	-,-	1	-
70	1 619 PA0 157	Pawl	1	-,-	1	-
71	1 619 PA0 158	Pan head screw	1	-,-	1	-
72	1 619 PA0 159	Safety Cover	1	-,-	1	-
73	1 619 PA0 160	Pan head screw	1	-,-	1	-
74	1 619 PA0 161	Spring	1	-,-	1	-
75	1 619 PA0 162	Knob	1	-,-	1	-
76	1 619 PA0 163	Indicator	1	-,-	1	-
77	1 619 PA0 164	Pan head screw	1	-,-	1	-
78	1 619 PA0 165	Protective Cover	1	-,-	1	-
79	1 619 PA0 166	Pawl	1	-,-	1	-
80	1 619 PA0 355	Spring	1	-,-	1	-
81	1 619 PA0 356	Pin	1	-,-	1	-
82	1 619 PA0 357	Pawl	1	-,-	1	-
83	1 619 PA0 358	Pan head screw	1	-,-	1	-
84	1 619 PA0 359	Nut	1	-,-	1	-
85	1 619 PA0 167	Fitting	1	-,-	1	-
86	1 619 PA0 168	Cable Clip	2	-,-	2	-
87	1 619 PA0 169	Fastening Clamp	2	-,-	1	-
88	1 619 PA0 170	Holder	2	-,-	1	-
89	1 619 PA0 171	Pan head screw	2	-,-	4	-
90	1 619 PA0 172	Rubber Retaining Ring	2	-,-	4	-
91	1 619 PA0 173	Plate	2	-,-	2	-
92	1 619 PA0 174	Bearing	2	-,-	1	-
93	1 619 PA0 175	Bearing	2	-,-	1	-
94	1 619 PA0 176	Bushing	2	-,-	1	-

Item	Part Number	Description	Illustration	Price	Quantity	Price Group
95	1 619 PA0 177	Knob	1	-,-	1	-
96	1 619 PA0 178	Retaining snap ring	1	-,-	2	-
97	1 619 PA0 179	Adjusting Slide	2	-,-	1	-
98	1 619 PA0 180	Pan head screw	1	-,-	2	-
99	1 619 PA0 181	Spring	1	-,-	1	-
100	1 619 PA0 182	Locking Pin	1	-,-	1	-
101	1 619 PA0 183	Locking Pin	1	-,-	1	-
102	1 619 PA0 184	Screw	1	-,-	1	-
103	1 619 PA0 185	Strip	2	-,-	1	-
104	1 619 PA0 186	Bar	2	-,-	1	-
105	1 619 PA0 187	Holder	2	-,-	1	-
111	1 619 PA0 194	Indicator	2	-,-	1	-
112	1 619 PA0 195	slide	2	-,-	1	-
113	1 619 PA0 196	Knob	2	-,-	1	-
114	1 619 PA0 197	Cover	2	-,-	1	-
115	1 619 PA0 198	Spring	2	-,-	1	-
116	1 619 PA0 199	Ball	2	-,-	1	-
117	1 619 PA0 200	Bit holder	2	-,-	1	-
118	1 619 PA0 201	Guide Block	2	-,-	1	-
119	1 619 PA0 202	Guide Pivot	2	-,-	1	-
120	1 619 PA0 360	Plate	2	-,-	6	-
121	1 619 PA0 203	Key Holder	2	-,-	1	-
122	1 619 PA0 204	Mains Key	2	-,-	1	-
123	1 619 PA0 205	Dust Bag	1	-,-	1	-
124	1 619 PA0 339	Nameplate	2	-,-	1	-
125	1 619 PA0 340	Warning Label	1	-,-	1	-
126	1 619 PA0 341	Warning Label	1	-,-	1	-
127	1 619 PA0 345	Warning Label	2	-,-	1	-
128	1 619 PA0 599	Warning Label	2	-,-	1	-
129	1 619 PA0 344	Warning Label	2	-,-	1	-
130	1 619 PA0 343	Warning Label	2	-,-	1	-
131	1 619 PA0 342	Warning Label	2	-,-	1	-
132	1 619 PA0 609	Rubber	2	-,-	2	-
800	1 619 PA0 348	Clamp	2	-,-	1	-
826	1 619 PA0 600	Gear	1	-,-	1	-
848	1 619 PA0 347	Brush	1	-,-	1	-
858	1 619 PA0 346	Handle	1	-,-	1	-

Illustration - Type E

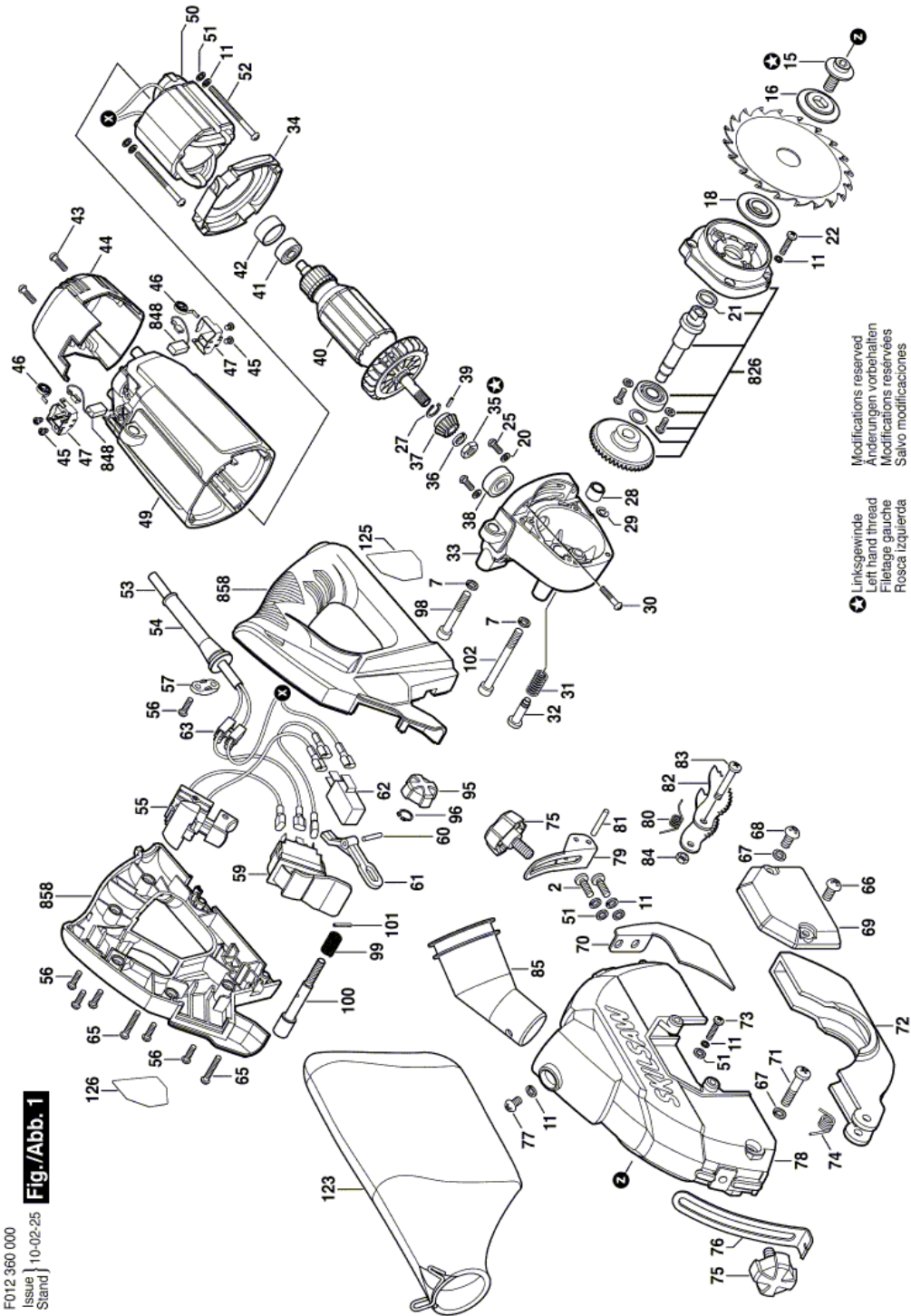
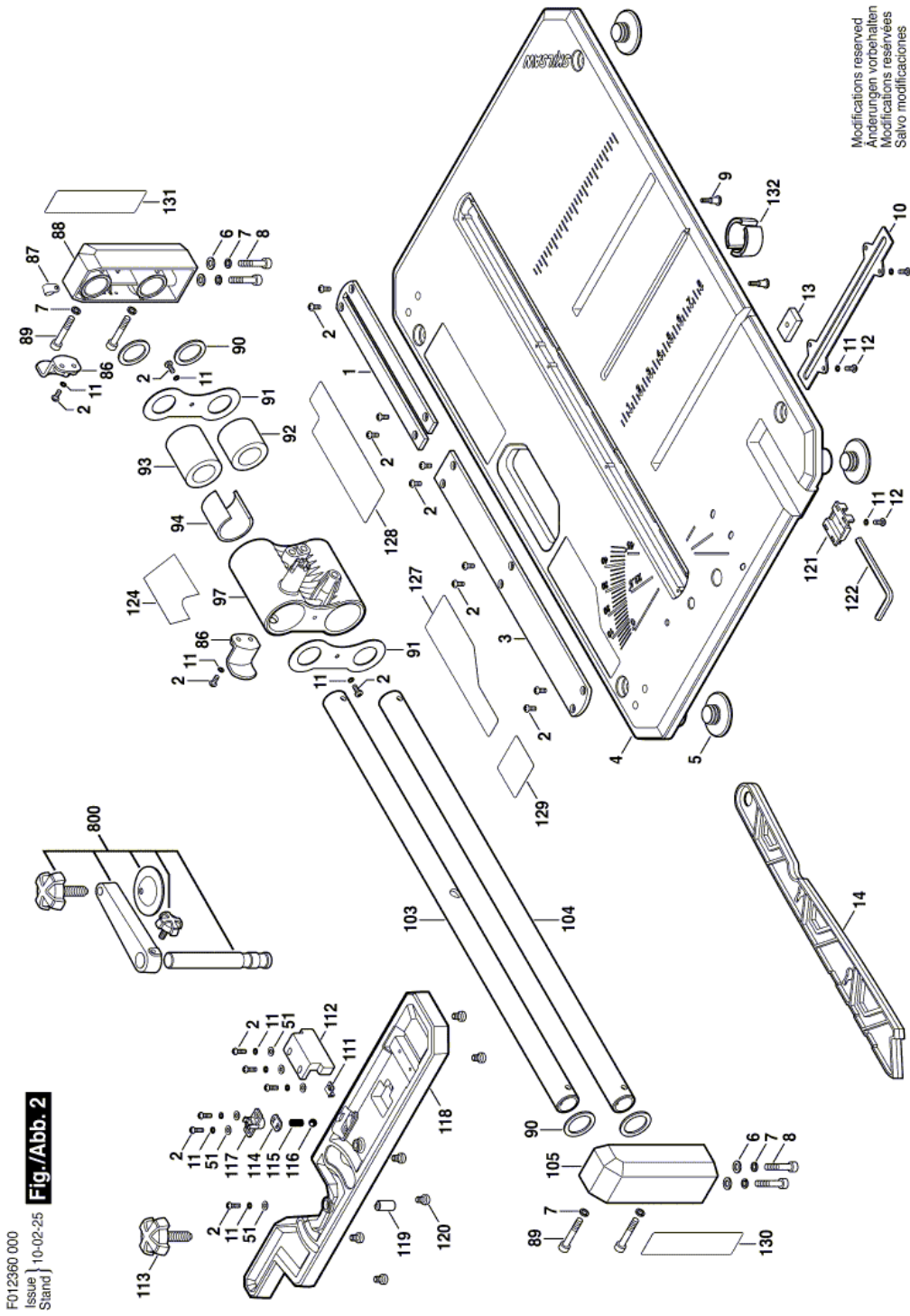

Illustration - Type E



F012360 000  
Issue 10-02-25  
Stand  
**Fig./Abb. 2**

Information subject to change without further notice.