



# SERVICE PARTS LIST

**BULLETIN NO.**  
**54-27-2800**

SPECIFY CATALOG NO. AND SERIAL NO. WHEN ORDERING PARTS		REVISED BULLETIN	DATE
<b>M18™ Brushless Threaded Rod Cutter</b>			Nov. 2019
<b>CATALOG NO.</b>	<b>2872-20</b>	<b>STARTING SERIAL</b>	<b>K38A and K38B</b>
		<b>WIRING INSTRUCTION</b> <b>SEE PAGE TWO</b>	

**EXAMPLE:**  
Component Parts (Small #) Are Included  
When Ordering The Assembly (Large #).

### Die Placement Guide

Dots indicate which jaw the dies fit into.

Single dot die to be placed into movable jaw.

Double dot die to be placed into fixed jaw.

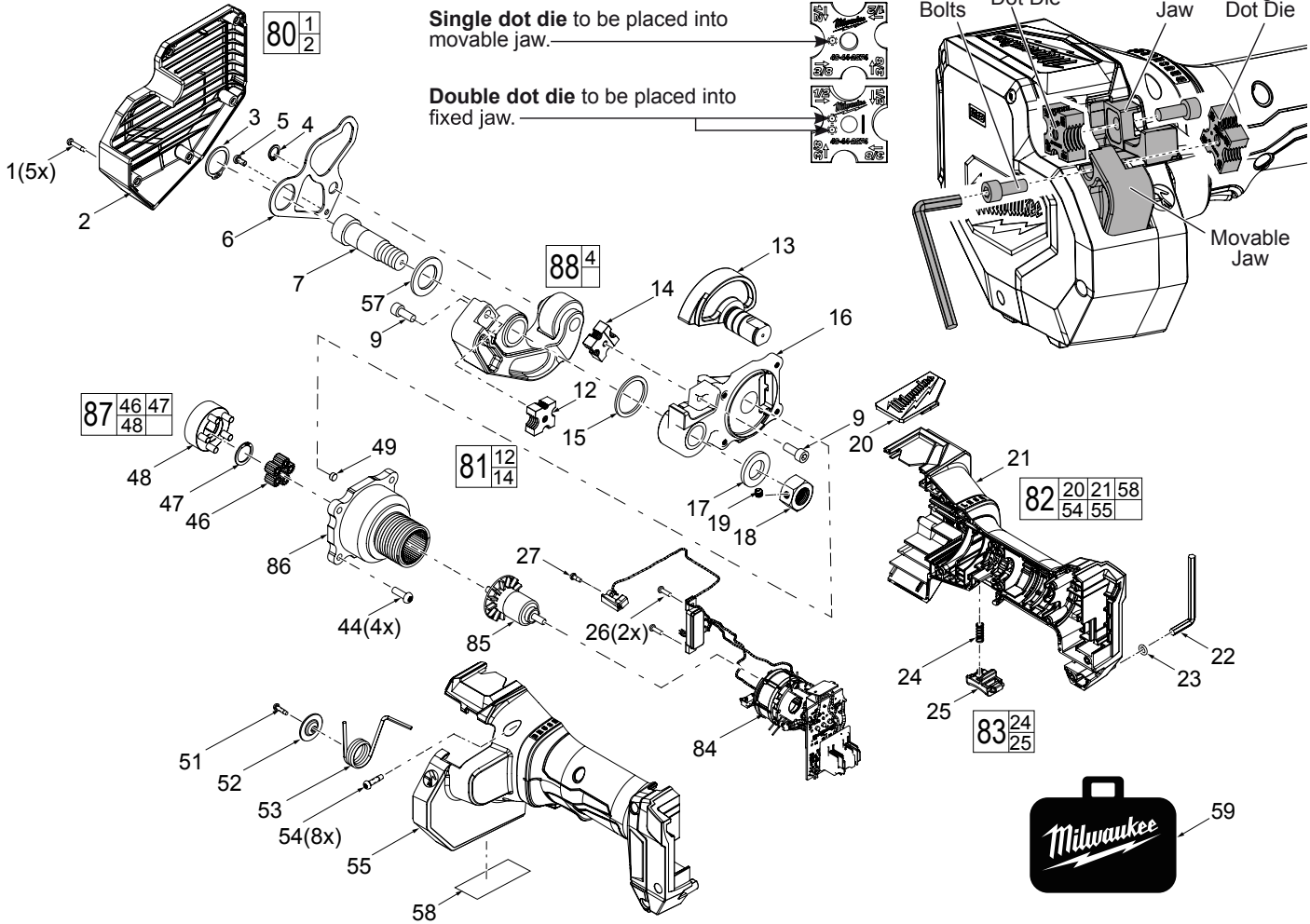
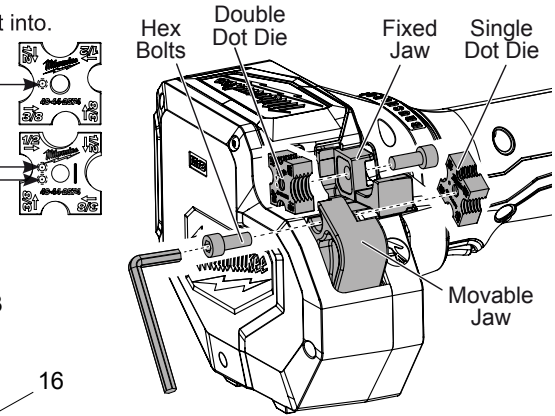
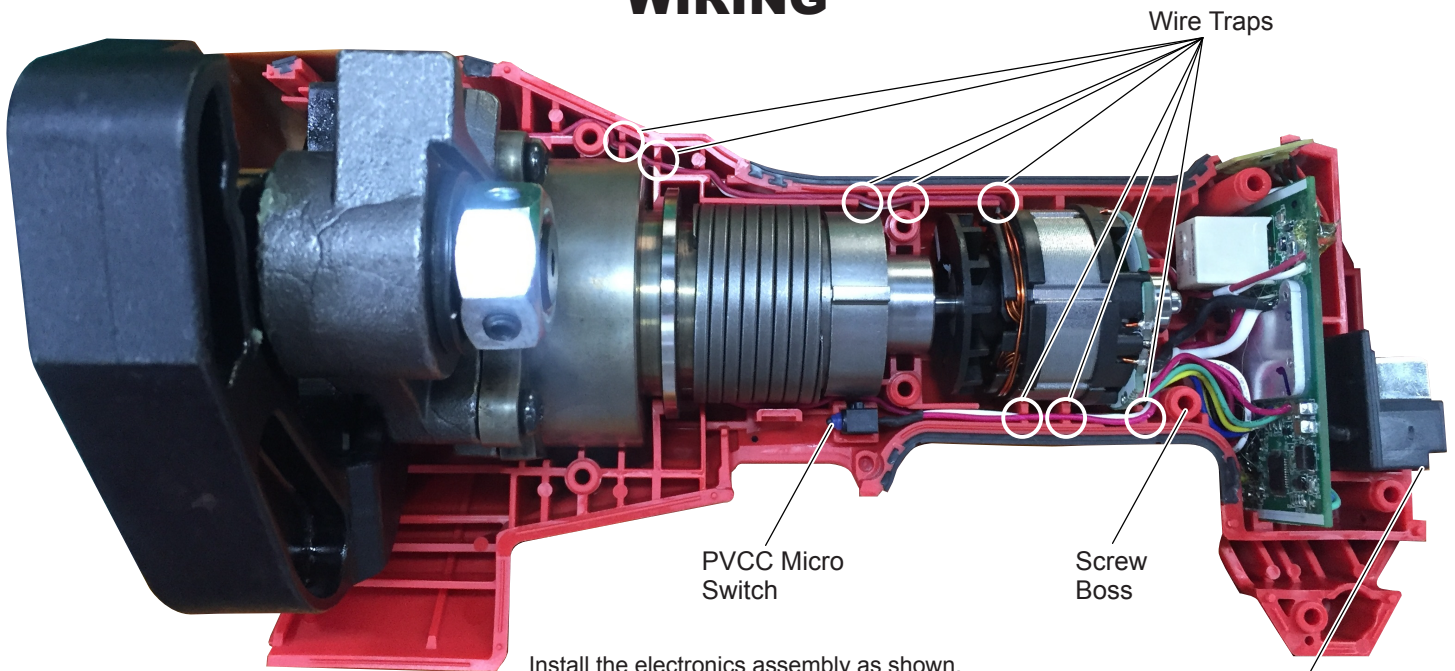
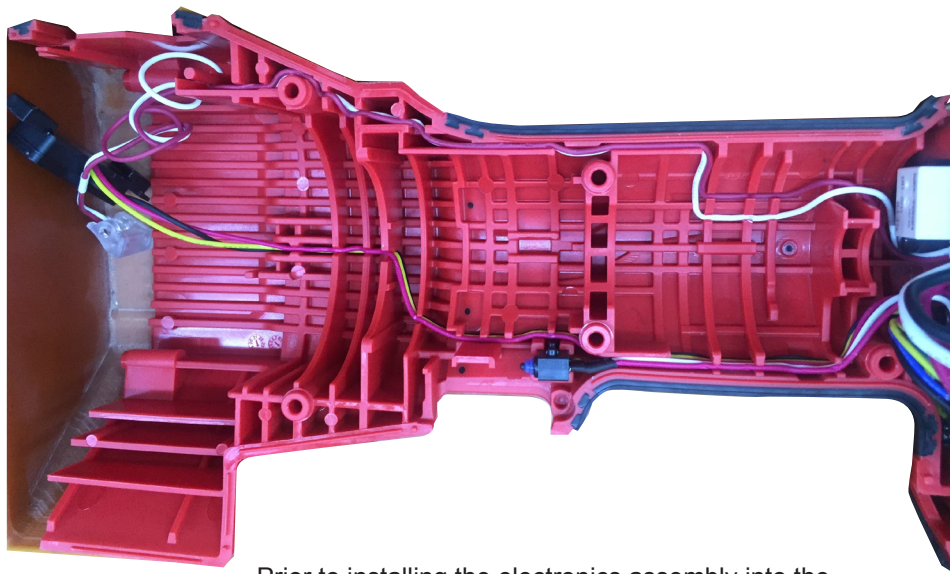

FIG.	PART NO.	DESCRIPTION OF PART	NO. REQ.	FIG.	PART NO.	DESCRIPTION OF PART	NO. REQ.
1	06-82-6350	M3 x 16mm Pan Hd. ST T-10 Screw	(5)	44	06-82-2873	M5 x 15mm Pan Hd. T-25 Mach. Screw	(4)
2	-----	Cover	(1)	46	-----	5th Planet Gear	(5)
3	34-60-2872	Retaining Ring	(1)	47	-----	Retaining Ring	(1)
4	34-60-2873	Retaining Ring	(1)	48	-----	Carrier Cam	(1)
5	06-82-3007	M4 x 8mm Pan Hd. T-20 Mach. Screw	(1)	49	44-26-2872	Magnet	(1)
6	44-66-2872	Guide Plate	(1)	51	06-82-1087	M3 x 12mm Pan Hd. ST T-10 Screw	(1)
7	06-14-2872	LH Bolt	(1)	52	42-14-2872	Metal Baffle	(1)
9	45-04-1095	M6 x 16mm Hex Socket Bolt	(2)	53	40-50-2872	Spring	(1)
12	-----	Bottom Die	(1)	54	05-88-1200	M4 x 16mm Pan Hd. ST T-20 Screw	(8)
13	42-50-2872	Cam	(1)	55	-----	Left Handle Halve - Cover	(1)
14	-----	Top Die	(1)	57	45-88-2890	Washer	(1)
15	43-44-0365	Gasket	(1)	58	12-20-2872	Service Nameplate	(1)
16	45-60-2872	Arm Support	(1)	59	42-55-2872	Blow Molded Carrying Case	(1)
17	45-88-2872	Washer	(1)	80	42-92-2872	Cover Kit	(1)
18	05-55-2872	M16 LH Hex Nut	(1)	81	43-04-2872	Die Kit	(1)
19	06-83-2872	Set Screw	(1)	82	31-44-2872	Handle Service Kit	(1)
20	-----	Logo Plate	(1)	83	45-72-2872	Trigger Kit	(1)
21	-----	Right Handle Halve - Support	(1)	84	14-20-2872	Electronics Assembly	(1)
22	45-96-2872	M5 Allen Key	(1)	85	16-01-2872	Rotor Assembly	(1)
23	34-40-4480	O-Ring	(1)	86	14-30-2872	Gearcase Assembly	(1)
24	40-50-0024	Spring	(1)	87	14-30-1025	Rear Gearcase Assembly Kit	(1)
25	-----	Switch Trigger	(1)	88	42-09-2872	Arm/Roller Assembly Kit	(1)
26	06-82-2872	M3 x 10mm Pan Hd. T-10 Screw	(2)				
27	06-82-0062	M3 x 8mm Pan Hd. ST T-10 Screw	(1)				

# WIRING



Install the electronics assembly as shown. Route wires around screw bosses and into wire traps. Be sure all components are seated squarely and firmly in place. Be sure there is no interference when installing the housing cover.



Prior to installing the electronics assembly into the housing support, place grounding terminal over screw boss as shown. Route ground wire, removing as much slack as possible. Be sure wire is pressed firmly to the back of the wire traps.

**AS AN AID TO REASSEMBLY, TAKE NOTICE OF WIRE ROUTING AND POSITION IN WIRE GUIDES AND TRAPS WHILE DISMANTLING TOOL.**

**BE SURE THAT ALL COMPONENTS OF THE ELECTRONICS KIT ARE SEATED FIRMLY AND SQUARELY IN THE HANDLE RECESSES.**

**AVOID PINCHED WIRES, BE SURE THAT ALL WIRES AND SLEEVES ARE PRESSED COMPLETELY DOWN IN WIRE GUIDES AND TRAPS.**

**PRIOR TO INSTALLING THE HANDLE COVER ONTO THE HANDLE SUPPORT, BE SURE THAT THERE ARE NO INTERFERENCES.**

# LUBRICATION

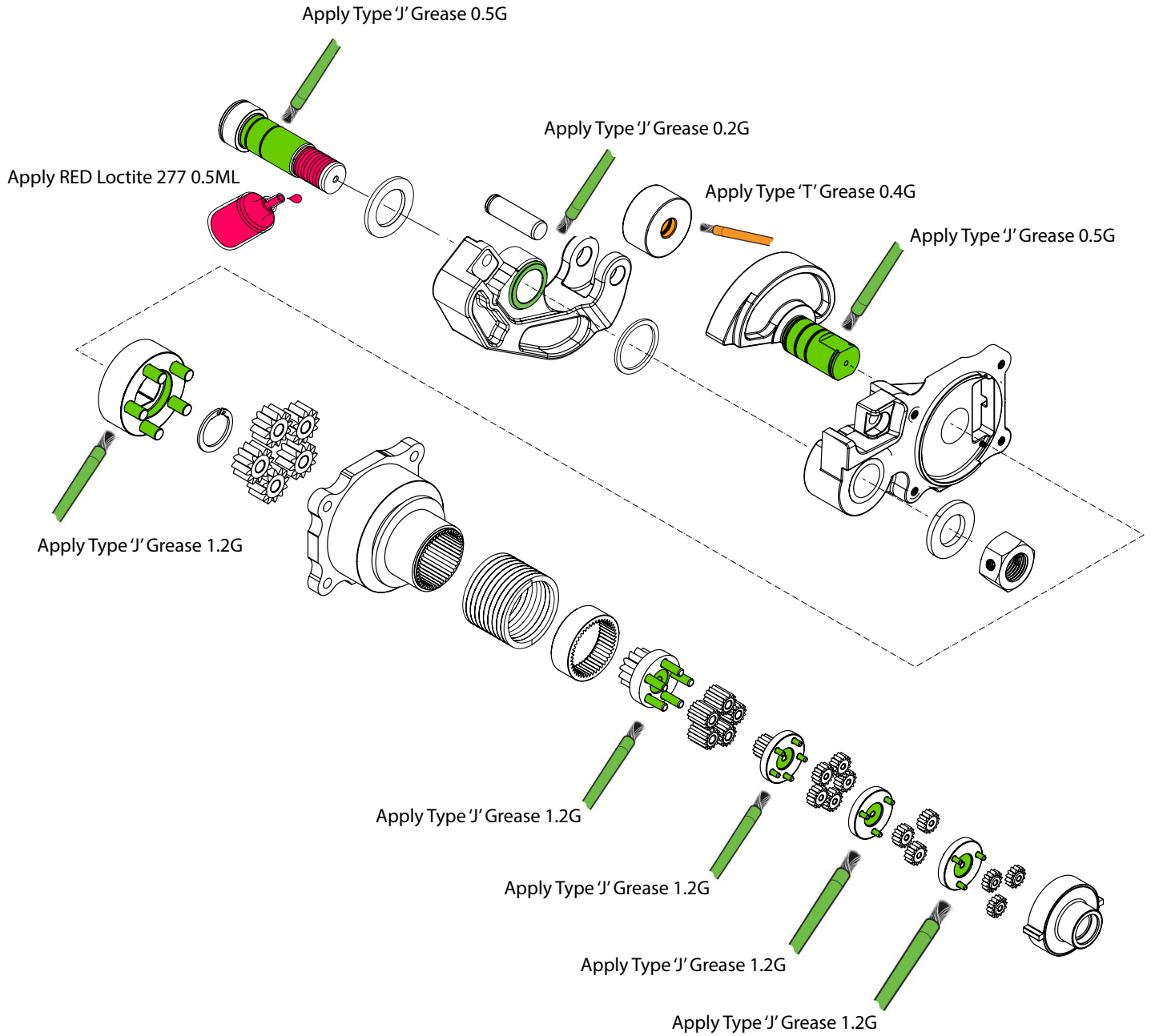

-  = Type 'J' Grease 48-08-4220
-  = 277 Red Loctite 44-22-0050
-  = Type 'T' Grease 49-08-4260