



SERVICE PARTS LIST

BULLETIN NO.
55-38-2680

SPECIFY CATALOG NO. AND SERIAL NO. WHEN ORDERING PARTS		REVISED BULLETIN	DATE
CORDLESS 18 VOLT 4-1/2" CUT-OFF/GRINDER			Aug. 2014
CATALOG NO.	2680-059	STARTING SERIAL NO.	D45A
		WIRING INSTRUCTION SEE PAGE 3	

EXAMPLE:
Component Parts (Small #) Are Included
When Ordering The Assembly (Large #).

★ = Part number change from
previous service parts list.

FIG. LUBRICATION:
(Use Type 'Y' grease, No. 49-08-5270)

10 Apply a thin coat of grease to the
Spindle Hub O-Ring.

13,38 Apply grease to all teeth of the
Pinion and Gear.

27 Place 1/8 oz. grease in Gearcase
cavity.

32,33 Apply a thin coat of grease between
Spindle Lock Shaft and O-Ring.

Functionally check the Spindle Lock
mechanism. Spindle Lock must
return briskly when released
from engagement in
Gear (13).

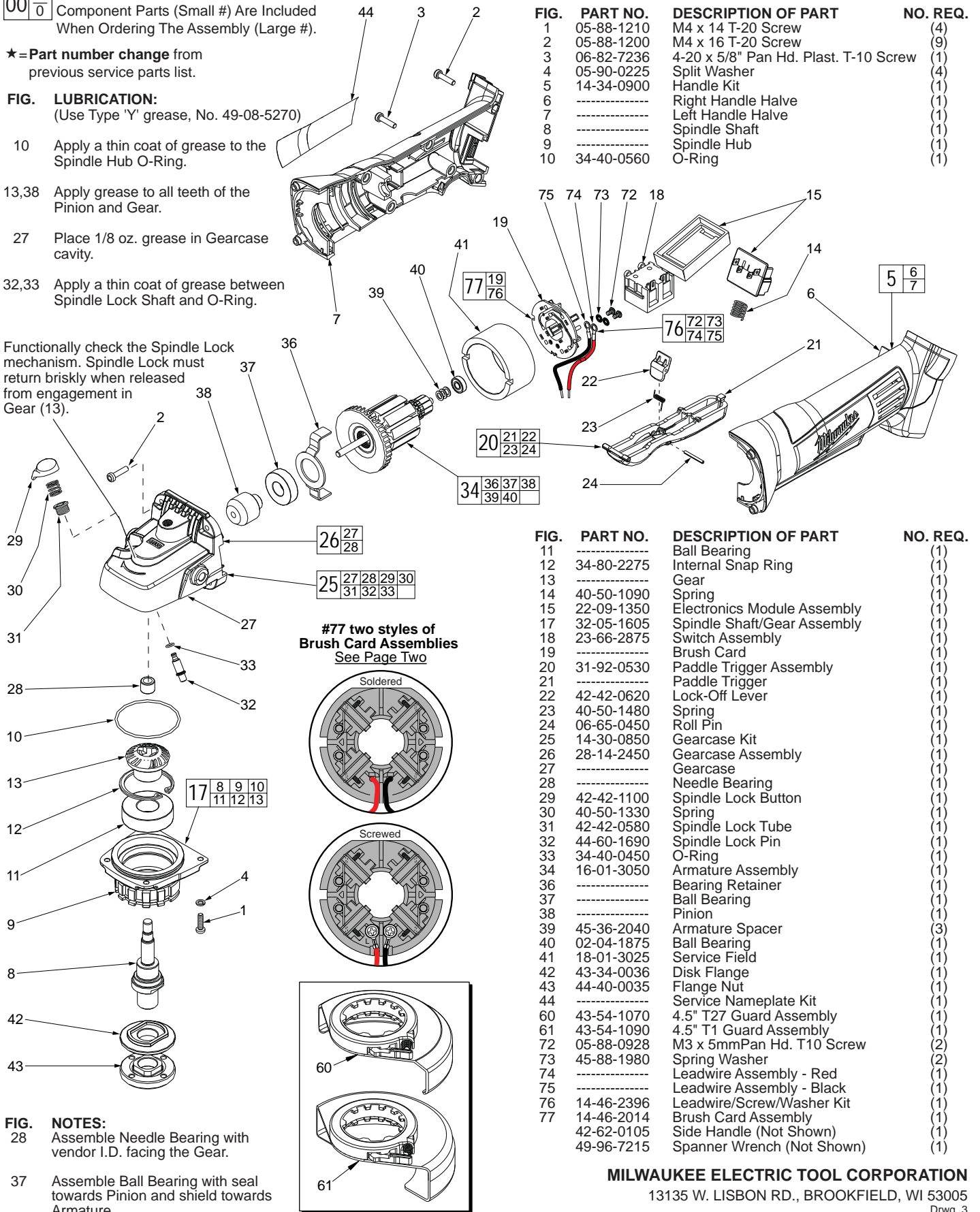

**#77 two styles of
Brush Card Assemblies
See Page Two**

FIG.	PART NO.	DESCRIPTION OF PART	NO. REQ.
1	05-88-1210	M4 x 14 T-20 Screw	(4)
2	05-88-1200	M4 x 16 T-20 Screw	(9)
3	06-82-7236	4-20 x 5/8" Pan Hd. Plast. T-10 Screw	(1)
4	05-90-0225	Split Washer	(4)
5	14-34-0900	Handle Kit	(1)
6	-----	Right Handle Halve	(1)
7	-----	Left Handle Halve	(1)
8	-----	Spindle Shaft	(1)
9	-----	Spindle Hub	(1)
10	34-40-0560	O-Ring	(1)

FIG.	PART NO.	DESCRIPTION OF PART	NO. REQ.
11	-----	Ball Bearing	(1)
12	34-80-2275	Internal Snap Ring	(1)
13	-----	Gear	(1)
14	40-50-1090	Spring	(1)
15	22-09-1350	Electronics Module Assembly	(1)
17	32-05-1605	Spindle Shaft/Gear Assembly	(1)
18	23-66-2875	Switch Assembly	(1)
19	-----	Brush Card	(1)
20	31-92-0530	Paddle Trigger Assembly	(1)
21	-----	Paddle Trigger	(1)
22	42-42-0620	Lock-Off Lever	(1)
23	40-50-1480	Spring	(1)
24	06-65-0450	Roll Pin	(1)
25	14-30-0850	Gearcase Kit	(1)
26	28-14-2450	Gearcase Assembly	(1)
27	-----	Gearcase	(1)
28	-----	Needle Bearing	(1)
29	42-42-1100	Spindle Lock Button	(1)
30	40-50-1330	Spring	(1)
31	42-42-0580	Spindle Lock Tube	(1)
32	44-60-1690	Spindle Lock Pin	(1)
33	34-40-0450	O-Ring	(1)
34	16-01-3050	Armature Assembly	(1)
36	-----	Bearing Retainer	(1)
37	-----	Ball Bearing	(1)
38	-----	Pinion	(1)
39	45-36-2040	Armature Spacer	(3)
40	02-04-1875	Ball Bearing	(1)
41	18-01-3025	Service Field	(1)
42	43-34-0036	Disk Flange	(1)
43	44-40-0035	Flange Nut	(1)
44	-----	Service Nameplate Kit	(1)
60	43-54-1070	4.5" T27 Guard Assembly	(1)
61	43-54-1090	4.5" T1 Guard Assembly	(1)
72	05-88-0928	M3 x 5mm Pan Hd. T10 Screw	(2)
73	45-88-1980	Spring Washer	(2)
74	-----	Leadwire Assembly - Red	(1)
75	-----	Leadwire Assembly - Black	(1)
76	14-46-2396	Leadwire/Screw/Washer Kit	(1)
77	14-46-2014	Brush Card Assembly	(1)
	42-62-0105	Side Handle (Not Shown)	(1)
	49-96-7215	Spanner Wrench (Not Shown)	(1)

FIG. NOTES:
28 Assemble Needle Bearing with
vendor I.D. facing the Gear.
37 Assemble Ball Bearing with seal
towards Pinion and shield towards
Armature.

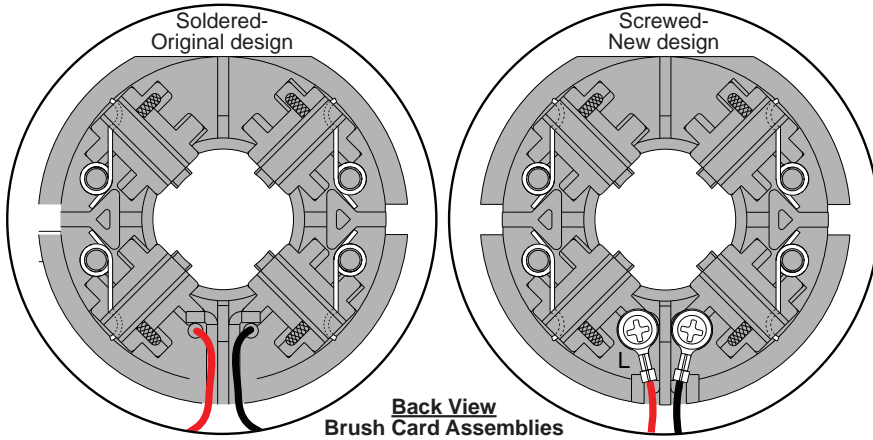

NOTE:
There are two Brush Card Assembly designs.

On the original brush card design the red and black wires that go to the switch are soldered on the brush card.

On the new brush card design the red and black wires that go to the switch are secured to the brush card with spring washers and screws.

The new brush card design is **directly interchangeable** in tools that have the old brush card design.

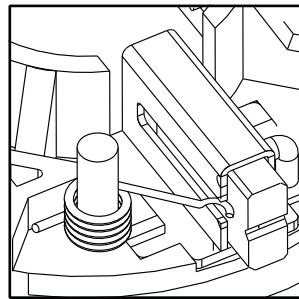
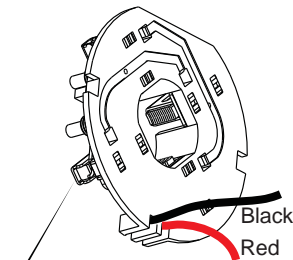

NOTE:
As an aid to prevent damage to the armature commutator or the brushes when removing and installing the armature assembly, it is recommended to pull the carbon brushes partially back into the brush tube. The carbon brushes will be held in place with the brush spring moving from the rear of the brush to the side of the brush.

In the unlikely event that the spring pops off follow the instructions below.

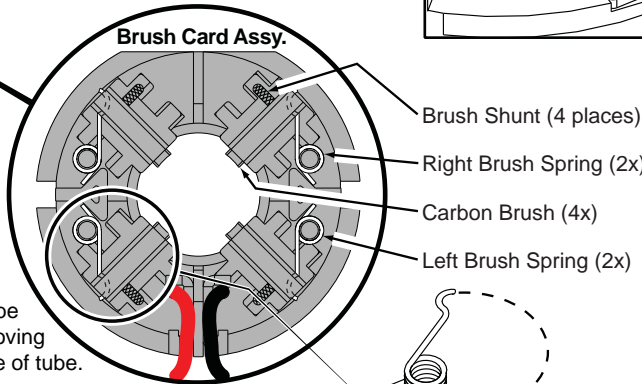

Be sure carbon brush is in brush tube with brush shunt moving freely in side groove of tube.

Place brush spring over post with short leg positioned downward as shown. Be sure spring is completely down with short leg trapped against 'Y' shaped wall on brush card.

While holding spring in place, bring the long leg of spring over the brush tube and through rear opening of tube. Position rounded hook of spring in groove on back of carbon brush. Be sure to check for free movement between carbon brush, brush shunt and brush spring.

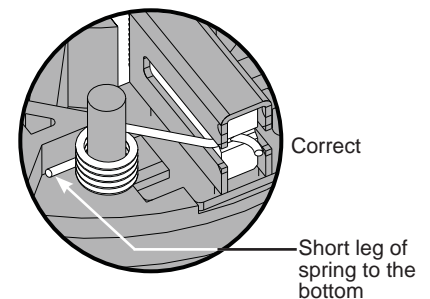
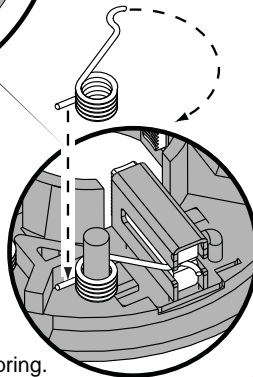

AS AN AID TO REASSEMBLY, TAKE NOTICE OF WIRE ROUTING AND POSITION IN WIRE GUIDES AND TRAPS WHILE DISMANTLING TOOL.

PC BOARD
(Component of the Electronics Module Assembly)

⑧ BLACK
(From Terminal Block to PCB)

SWITCH ASSEMBLY

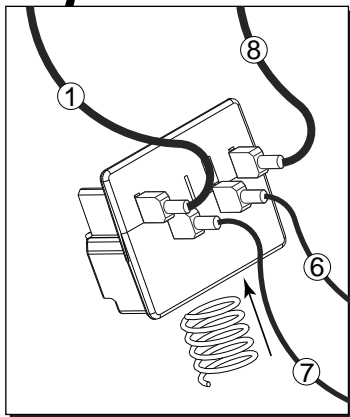
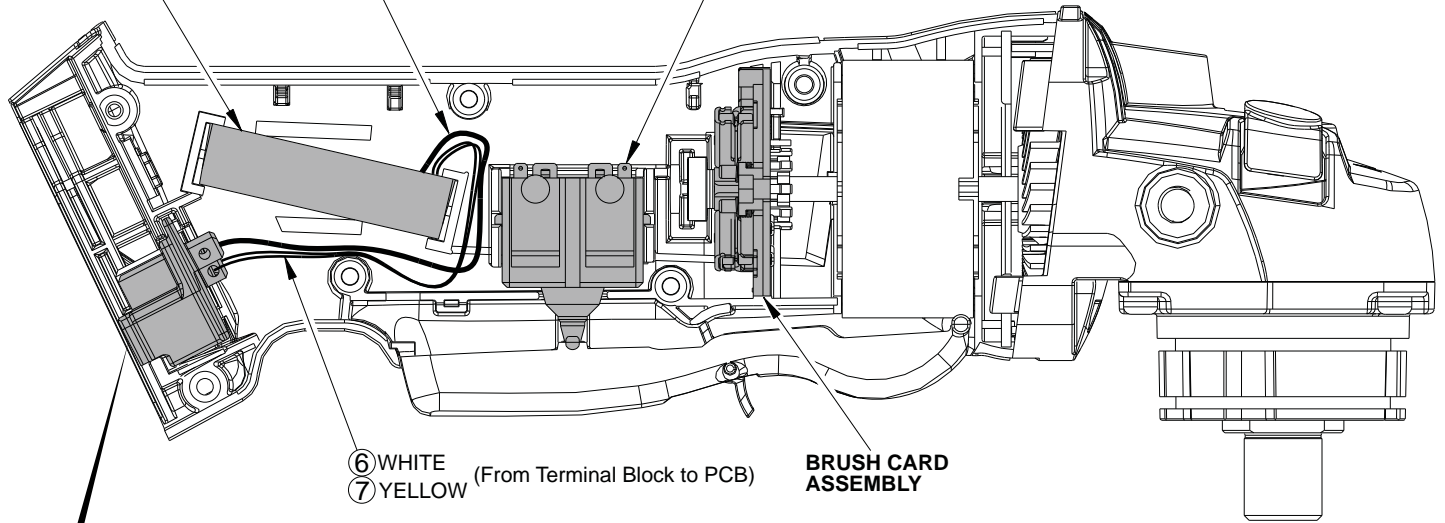

BLACK ②
(From Switch to PCB)

④ BLACK
(From Brush Card to Switch)

RED ③ (From Switch to PCB)

⑤ RED
(From Brush Card to Switch)

CONNECTOR BLOCK
(Component of the Electronics Module Assembly)

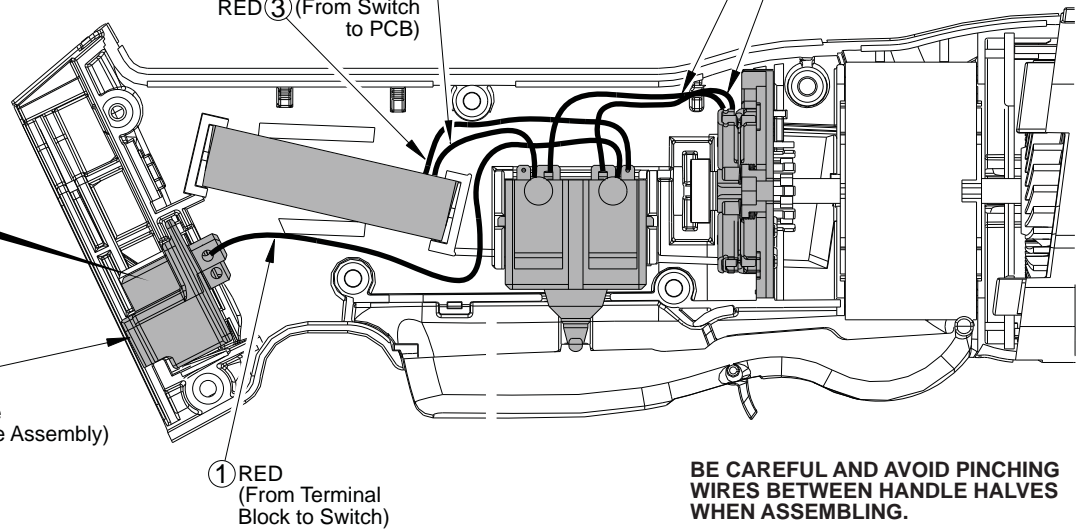

BE CAREFUL AND AVOID PINCHING WIRES BETWEEN HANDLE HALVES WHEN ASSEMBLING.

WIRING SPECIFICATIONS

Wire No.	Wire Color	Origin or Gauge	Length	Terminals, Connectors and 1 or 2 End Wire Preparation
1	Red	14	-----	Component of the Electronics Module Assembly.
2	Black	14	-----	Component of the Electronics Module Assembly.
3	Red	18	-----	Component of the Electronics Module Assembly.
4	Black	15	-----	Component of the Brush Card Assembly.
5	Red	15	-----	Component of the Brush Card Assembly.
6	White	24	-----	Component of the Electronics Module Assembly.
7	Yellow	24	-----	Component of the Electronics Module Assembly.
8	Black	14	-----	Component of the Electronics Module Assembly.

