



SERVICE PARTS LIST

BULLETIN NO.
55-40-2645

SPECIFY CATALOG NO. AND SERIAL NO. WHEN ORDERING PARTS		REVISED BULLETIN	DATE
CORDLESS M18 ORBITAL JIG SAW			Aug. 2013
CATALOG NO. 2645-059	SERIAL NUMBER D42A	WIRING INSTRUCTION SEE PAGE 4	

00 0

EXAMPLE:
Component Parts (Small #) Are Included
When Ordering The Assembly (Large #).

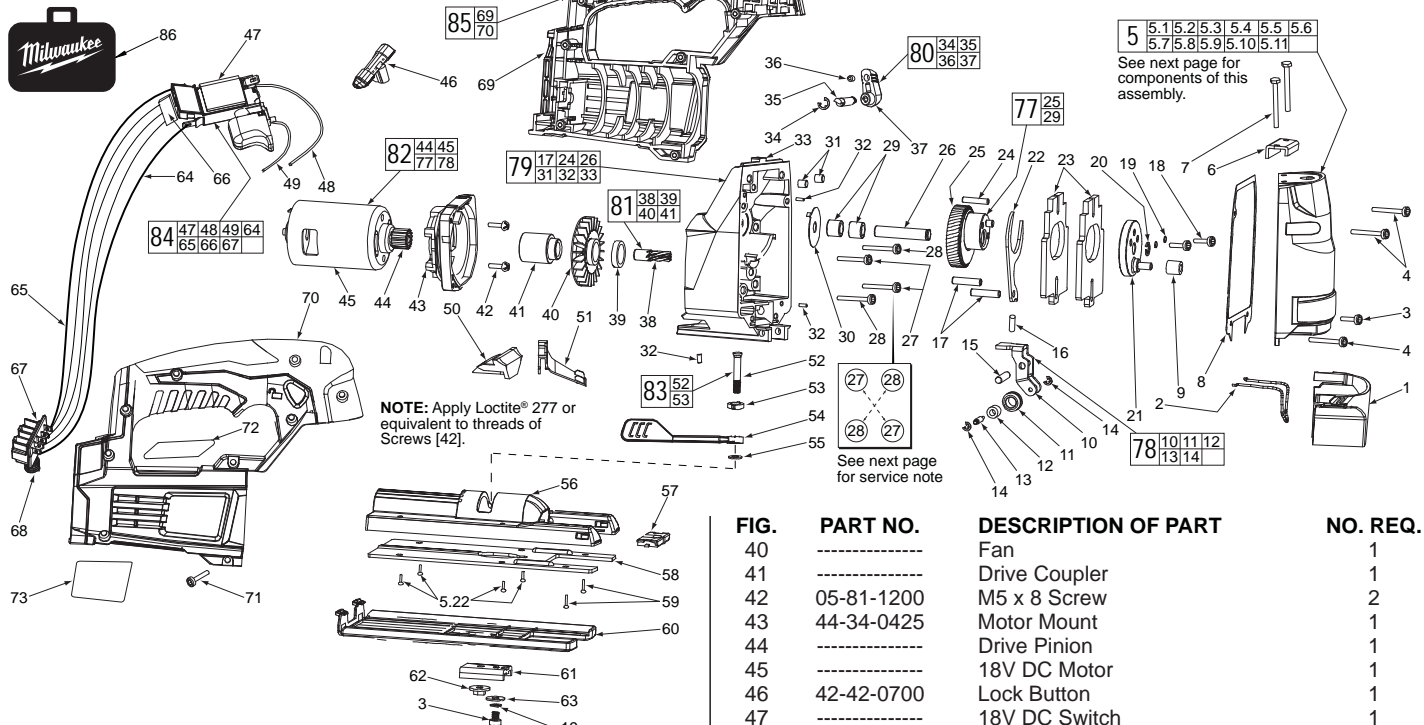

NOTE: Apply Loctite® 277 or equivalent to threads of Screws [42].

See next page for service note

FIG.	PART NO.	DESCRIPTION OF PART	NO. REQ.
1	42-92-1160	Blade Cover	1
2	43-54-0780	Guard Wire	1
3	05-81-1030	M4 x 9.0 T-20 Screw	2
4	05-81-1040	M4 x 16 T-20 Screw	3
5	14-20-4000	Gearcase Cover Assembly	1
5.22	05-81-1050	M4 Flat Head Screw	4
6	42-28-0450	Support Block	1
7	05-81-1060	M4 x 44 Pan Head T-20 Screw	2
8	43-44-0610	Gasket	1
9	02-50-1260	Needle Bearing	1
10	-----	Blade Guide Holder	1
11	-----	Blade Guide	1
12	-----	Needle Bearing	1
13	-----	4.0 x 11 Pin	1
14	-----	E-Ring	2
15	06-65-0410	5.0 x 23.5 Pin	1
16	06-65-0420	5.0 x 9.6 Pin	1
17	-----	5.0 x 22 Pin	2
18	05-81-1070	M4 x 12 Screw	2
19	45-88-1890	Spring Washer	3
20	34-60-0750	E-Ring	1
21	44-66-1510	Eccentricity Plate	1
22	44-66-1630	Drive Plate	1
23	42-28-0500	Counter Balance	2
24	-----	4 x 23 Pin	1
25	-----	Output Gear	1
26	-----	8 x 43 Pin	1
27	05-81-1080	M4 x 25 Screw	2
28	05-81-1090	M4 x 24 Screw	2
29	-----	Needle Bearing	2
30	45-88-3070	Washer	1
31	-----	Rubber Knock	2
32	-----	2.5 x 7.5 Pin	3
33	-----	Gearcase	1
34	34-60-0770	E-Ring	1
35	-----	Orbital Adjustment Shaft	1
36	-----	Orbital Adjustment Stop	1
37	-----	Orbital Adjustment Lever	1
38	-----	Spiral Pinion Shaft	1
39	-----	Ball Bearing	1

FIG.	PART NO.	DESCRIPTION OF PART	NO. REQ.
40	-----	Fan	1
41	-----	Drive Coupler	1
42	05-81-1200	M5 x 8 Screw	2
43	44-34-0425	Motor Mount	1
44	-----	Drive Pinion	1
45	-----	18V DC Motor	1
46	42-42-0700	Lock Button	1
47	-----	18V DC Switch	1
48	-----	Red Leadwire	1
49	-----	Black Leadwire	1
50	42-68-0880	Clamping Claw	1
51	43-56-0695	Airflow Baffle	1
52	-----	M6 x 31 Bolt	1
53	-----	Fix Wedge	1
54	44-10-0700	Adjustable Base Lever	1
55	45-88-1990	Washer	1
56	28-06-1280	Adjustable Shoe	1
57	43-84-1030	Anti-Splintering Insert	1
58	42-92-1580	Slide Plate	1
59	05-88-1208	M4 x 13 Flat Head Screw	2
60	31-15-0690	Plastic Cover	1
61	31-17-0570	Shoe Retainer	1
62	05-59-0900	M6 x 7 Nut	1
63	45-88-2060	Washer	1
64	-----	Red Leadwire	1
65	-----	Black Leadwire	1
66	-----	Connector Assembly	1
67	22-56-0025	Terminal Block Assembly	1
68	40-50-1090	Compression Spring	1
69	-----	Support Housing (Left Handle Half)	1
70	-----	Housing Cover (Right Handle Half)	1
71	05-86-1200	M4 x 16 Pan Head Plastite T-20 Screw	9
72	10-15-3121	Warning Label	1
73	-----	Service Nameplate Kit	1
77	32-30-0200	Gear Assembly	1
78	42-36-0280	Blade Guide Assembly	1
79	14-30-0980	Gearcase Assembly	1
80	30-58-0100	Orbit Lever Assembly	1
81	36-66-4490	Pinion Assembly	1
82	23-30-0780	Motor Assembly	1
83	30-58-0125	Tension Lever Assembly	1
84	23-66-2961	Switch Assembly	1
85	31-44-2375	Handle Halves Assembly	1
86	42-55-2645	Carrying Case, Optional	1

FIG.	PART NO.	DESCRIPTION OF PART	NO. REQ.
5	14-20-4000	Gearcase Cover Assembly	1
5.1	-----	Gearcase Cover	1
5.2	-----	Lever	1
5.3	-----	Link Rod	1
5.4	-----	2.8 x 14 Pin	2
5.5	44-10-0690	Sleeve Lever	1
5.6	45-22-0190	Rotate Sleeve	1
5.7	05-86-0300	M3 x 22.5 Slotted Screw	1
5.8	40-50-4410	Tension Spring	1
5.9	-----	2.5 x 25 Pin	1
5.10	-----	E-Ring	1
5.11	-----	4.0 x 30 Pin	1
5.12	-----	Cover Plate	1
5.13	-----	Rubber Seal	1
5.14	-----	Felt Seal	1
5.15	-----	Fiber Seal	1
5.16	-----	Bushing	2
5.17	40-50-0780	Compression Spring	2
5.18	-----	Saw Bar Guide	1
5.19	06-65-0310	5 x 46 Pin	1
5.20	44-74-0170	Pivot Post	2
5.21	44-66-1290	Pressing Plate	1
5.22	05-81-1050	M4 Flat Head Screw	2
5.23	-----	Cover Plate	1
5.24	-----	Saw Bar	1
5.25	-----	Compression Spring	1
5.26	-----	Clamp Plate	1
5.27	-----	Torsion Spring	1
5.28	-----	Blade Clamp Sleeve	1
5.29	-----	Connecting Link	1
5.30	-----	M4 x 10 Screw	2
5.31	-----	Pin	1
76	38-50-0750	Spindle Assembly	1

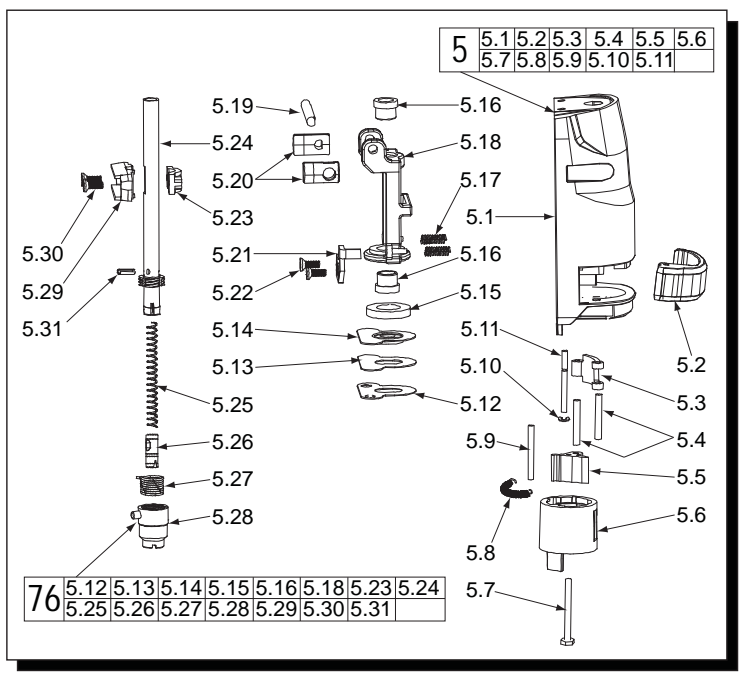

Service Notes for 2645 Cordless Jigsaw

IMPORTANT: Place both of the Counter Balance Blocks (23) into the Gearcase (33) with the shorter flat sides positioned to the left side in the Gearcase (as viewed from the front of tool).

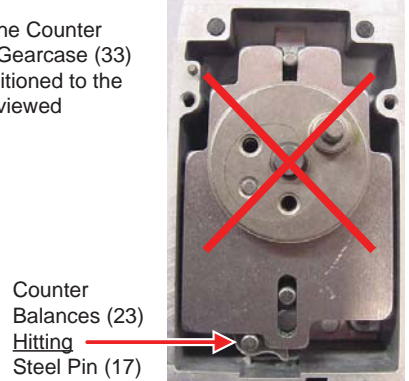

Counter Balances Installed INCORRECTLY

Counter Balances (23) come into contact with Steel Pin (17) inside Gearcase (33).

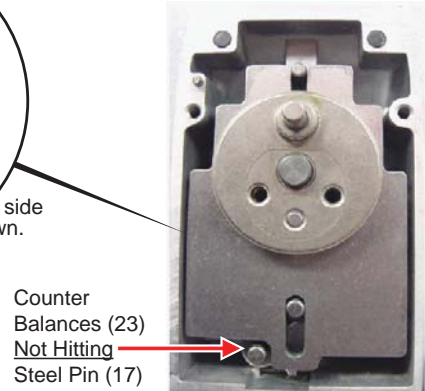
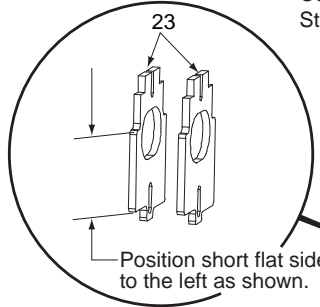

Counter Balances Installed CORRECTLY

Counter Balances (23) do not come into contact with Steel Pin (17) inside Gearcase (33). Approximately .065 clearance between bottom of Counter Balances and Steel Pin.

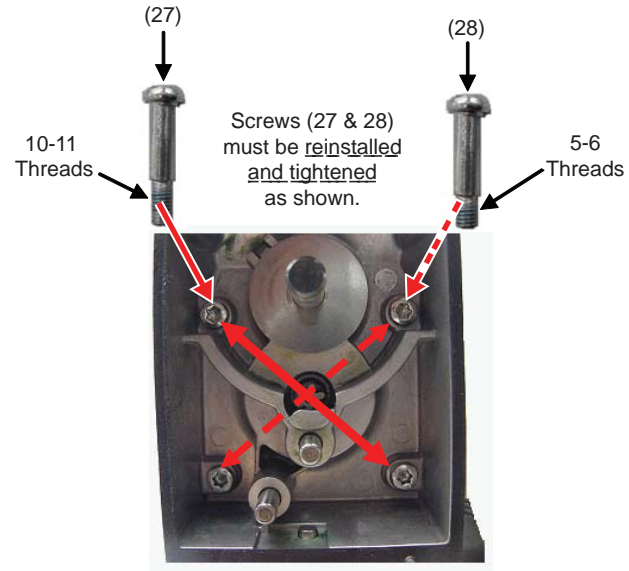

Front View of Gearcase
Overall length of screws are identical although length of threads are different

TORQUE SPECIFICATIONS			
Fig.	Part No.	Min. (In-Lbs)	Max. (In-Lbs)
3	05-81-1030	15	25
4	05-81-1040	15	30
5.7	05-86-0300	4	6
5.22	05-81-1050	15	25
5.30	-----	20	30
7	05-81-1060	7	15
18	05-81-1070	25	25
27	05-81-1080	15	25
28	05-81-1090	15	25
42	05-81-1200	20	30
59	05-88-1208	15	25
71	05-86-1200	7	15

Service Notes for 2645 Cordless Jigsaw - continued

Disassembly

FIG. 18,19,20,21,26 **NOTES:** Eccentricity Plate (21) Screws and Lock Washers (18-19) must be removed prior to removing E-clip (20) from Gearcase Pin (26) to prevent damaging the E-clip. See Fig. 1

33,38,39,40,41 Remove Motor Pinion Assembly (81) from Gearcase (33) by placing a 3/32" pin punch into the center counter bore of Pinion (38) and gently tapping assembly until removed from Gearcase (33). See Fig. 2

1,5 Remove Plastic Blade Cover (1) from the Gearcase Cover (5) by gently squeezing raised plastic tabs on both sides of cover simultaneously and pulling forward.

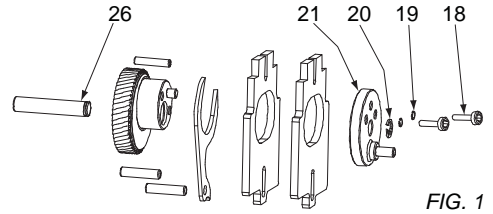

FIG. 1

Reassembly

42 Secure Motor Mount Plate Screws (42) with Blue Loctite® No. 44-22-0090 if removed.

18,19,20,21 E-clip (20) must be reinstalled onto Gearcase Pin (26) prior to installing Eccentricity Plate (21) Screws and Lock Washers (18-19) to prevent damaging E-clip. See Fig. 1

22,23,33 Bevel side of Counter Balance Plates (23) must face Rocker Arm Plate (22) when installed into Gearcase (33). (Reference assembly Illustration picture).

2,3,4,5,7,33 Reinstall Wire Guard (2) onto Gearcase (33) by positioning round prongs of guard thru Gearcase cover (5) and place wires into round holes provided in Gearcase (33) prior to securing Gearcase Screws (3-4-7). See Fig. 3

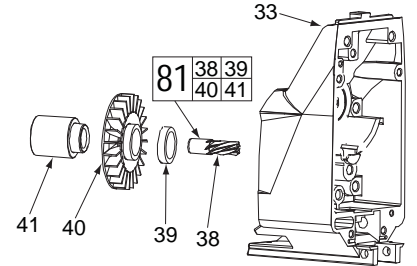

FIG. 2

LUBRICATION NOTES:

Use Type 'J' Grease, No. 49-08-4220

When servicing, remove 90-95% of the existing grease prior to installing Type "J". Original grease maybe similar in color but not compatible with "J"

Coat internal components of Gearcase (33) with approx. 1/4 oz. grease (front and back) prior to installing into Gearcase. (Lightly coat steel pins (17, 24, 26) inside Gearcase prior to reassembly)

Coat internal components of Gearcase Cover (5) with approx. 1/8 oz. grease and place another approx. 1/8 oz. grease in the top of the Gearcase Cover.

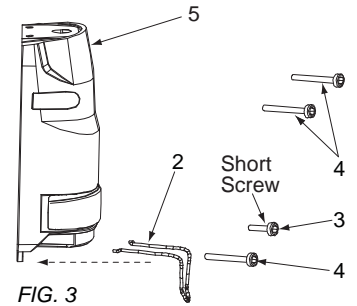
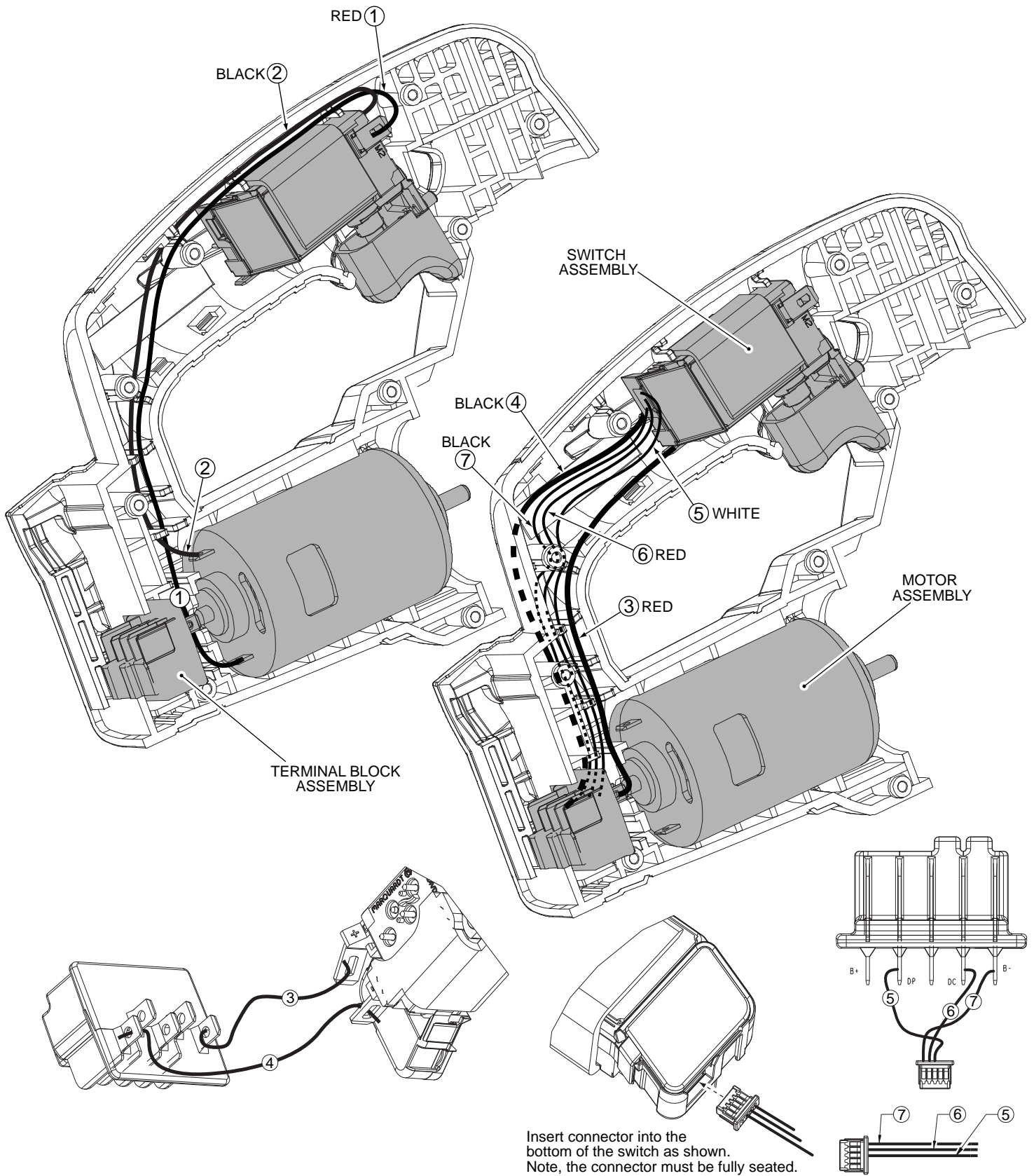

FIG. 3

SEE PAGE 4 FOR WIRING INSTRUCTIONS



Insert connector into the bottom of the switch as shown. Note, the connector must be fully seated.

WIRING SPECIFICATIONS

Wire No.	Wire Color	Origin or Gauge	Length	Terminals, Connectors and 1 or 2 End Wire Preparation
1	Red	14	-----	Component of the Switch Assembly 23-66-2960.
2	Black	14	-----	Component of the Switch Assembly 23-66-2960.
3	Red	14	-----	Component of the Switch Assembly 23-66-2960.
4	Black	14	-----	Component of the Switch Assembly 23-66-2960.
5	White	28	-----	Component of the Switch Assembly 23-66-2960.
6	Red	28	-----	Component of the Switch Assembly 23-66-2960.
7	Black	28	-----	Component of the Switch Assembly 23-66-2960.

AS AN AID TO REASSEMBLY, TAKE NOTICE OF WIRE ROUTING AND POSITION IN WIRE GUIDES AND TRAPS WHILE DISMANTLING TOOL.

BE CAREFUL AND AVOID PINCHING WIRES BETWEEN HANDLE HALVES WHEN ASSEMBLING.