



SERVICE PARTS LIST

BULLETIN NO.
54-26-2491

SPECIFY CATALOG NO. AND SERIAL NO. WHEN ORDERING PARTS		REVISED BULLETIN	DATE
M12 Brushless 3/8" Square Impact Driver		54-26-2490	Jan. 2013
CATALOG NO. 2454-20	STARTING SERIAL NO. E52B	WIRING INSTRUCTION SEE PAGE 2	

IMPORTANT NOTE: Gearcase end cap #25 is LEFT HAND THREAD!

As an aid to assembly, carefully lower the complete front end of tool (gearcase / impacting system) onto the gearcase end cap. Gently hand tighten front end assembly onto gearcase end cap. Be careful not to cross-thread! Once installed by hand, seat gearcase end cap with a 9/16" open end wrench using light pressure. Do not over tighten!

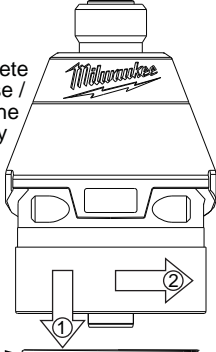

LEFT HAND THREAD

**Torque to 260 in/lbs ±24 in/lbs
(300 kgf-cm ±27 kgf-cm)**

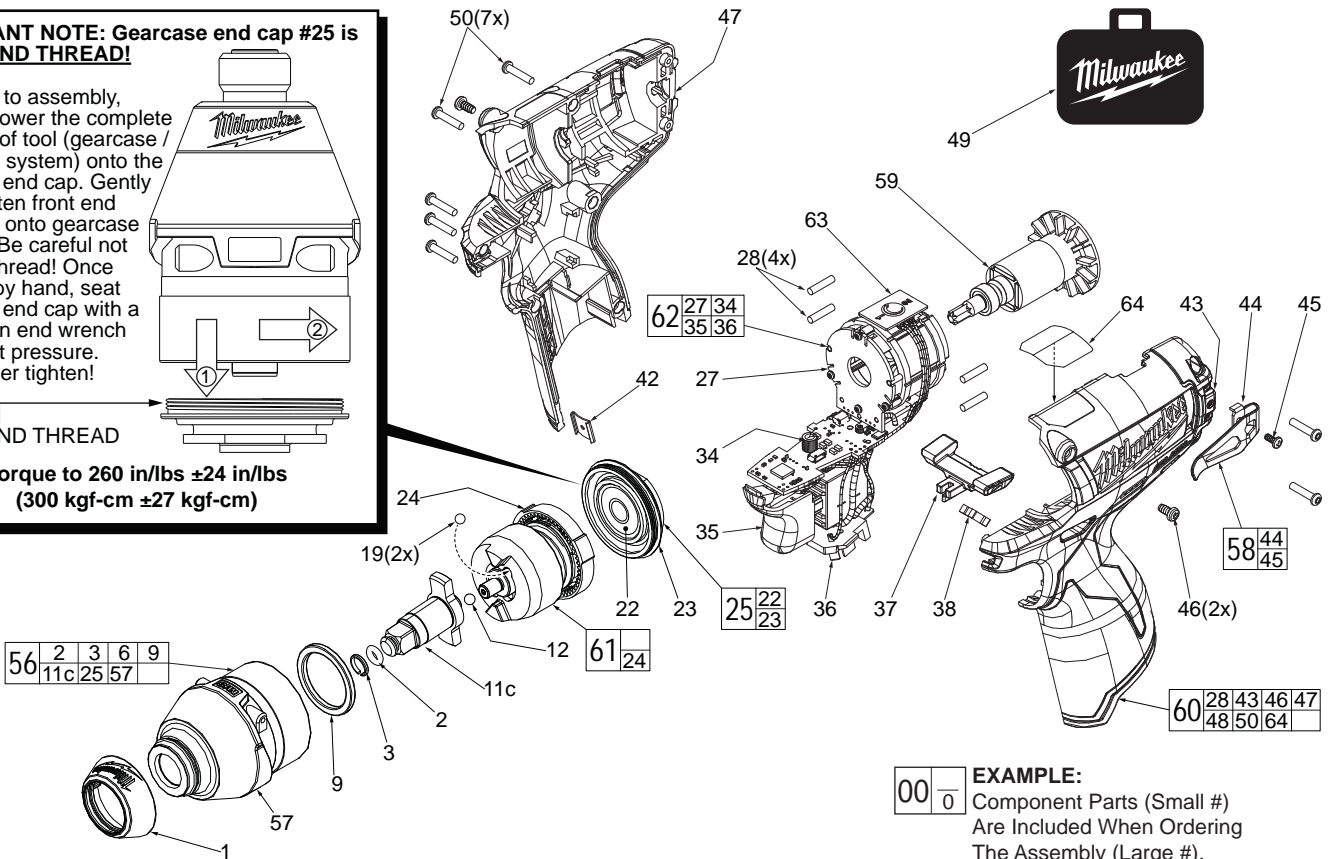

EXAMPLE:
Component Parts (Small #)
Are Included When Ordering
The Assembly (Large #).

FIG.	PART NO.	DESCRIPTION OF PART	NO. REQ.
1	31-12-0610	Rubber Cap	(1)
2	34-40-1885	3/8" O-Ring	(1)
3	44-90-1050	3/8" Friction Ring	(1)
6	-----	Anvil Bushing (Not Shown)	(1)
9	45-88-2135	Plastic Washer	(1)
11c	42-06-0225	3/8" Square Anvil	(1)
12	02-02-1300	5mm Steel Ball	(1)
19	02-02-0180	4.7mm Steel Ball	(2)
22	-----	Ball Bearing	(1)
23	-----	Gearcase End Cap	(1)
24	-----	Ring Gear	(1)
25	44-66-1065	Gearcase End Cap Assembly	(1)
27	-----	Stator Assembly	(1)
28	45-30-0300	Rubber Slug	(4)
34	-----	PCBA	(1)
35	-----	On-Off Switch	(1)
36	-----	Terminal Block Assembly	(1)
37	45-24-0810	Fwd/Rev Shuttle	(1)
38	40-50-1135	Spring	(1)
42	42-70-0055	Housing Clip	(1)
43	-----	Left Handle Halve with Fuel Gauge	(1)
44	42-70-0580	Belt Clip	(1)
45	-----	Belt Hook Screw	(1)
46	06-82-1090	M3 x 7mm Pan Hd. Plastite Screw	(2)
47	-----	Right Handle Halve	(1)
48	12-20-2435	Service Nameplate (Not Shown)	(1)
49	42-55-1060	Carrying Case	(1)

FIG.	PART NO.	DESCRIPTION OF PART	NO. REQ.
50	06-82-7236	4-20 x 5/8" Pan Hd. Plastite T-10 Scr	(7)
56	14-30-1190	Gearcase Assembly	(1)
57	28-50-0950	Front Gearcase with Bushing	(1)
58	42-70-0490	Belt Clip Assembly	(1)
59	16-07-0420	Rotor Assembly	(1)
60	31-44-2453	Handle Assembly	(1)
61	14-30-1220	Impacting Assembly	(1)
62	14-20-1520	Electronics Assembly	(1)
63	23-66-2455	POP Switch	(1)
64	10-20-2845	Spanish/French Warning Label	(1)

**FIG. LUBRICATION
(Type 'J' Grease, No. 49-08-4220):**

- 11c Lightly coat front washer surface of anvil (11c) with grease.
- 24,61 Lightly coat the I.D. of the ring gear (24) and the center of the planet gears of impacting assembly with grease.
- 57 Coat inside of bushing inside front gearcase with grease.
- 59 Coat pinion of rotor assembly (59) with grease.

AS AN AID TO REASSEMBLY, TAKE NOTICE OF WIRE ROUTING AND POSITION IN WIRE GUIDES AND TRAPS WHILE DISMANTLING TOOL.

BE CAREFUL AND AVOID PINCHING WIRES BETWEEN HANDLE HALVES WHEN ASSEMBLING.

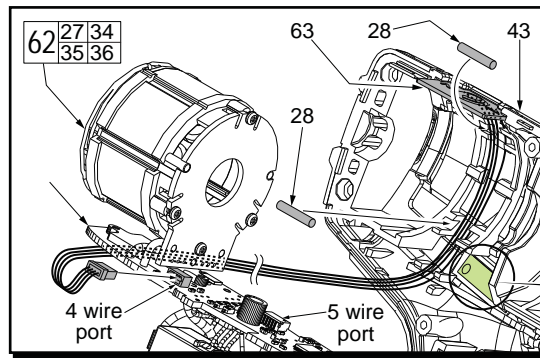

The fuel gauge assembly is a fixed component of the left handle half (43). Connect the five wire terminal block to the corresponding five wire port on the PCBA.

Place POP Switch (63) into top slot of left handle half. Be sure that the '2' is positioned to the back of tool. Route the four wires through the channel along the inside wall as shown. Trap the wires in place using two Rubber Slugs (28). Carefully place all components of the Electronics Assembly (62) into the handle half. Connect the four wire terminal to the port on PCBA (34).

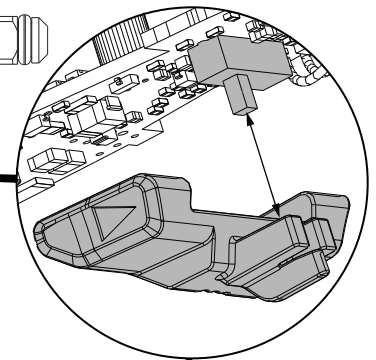
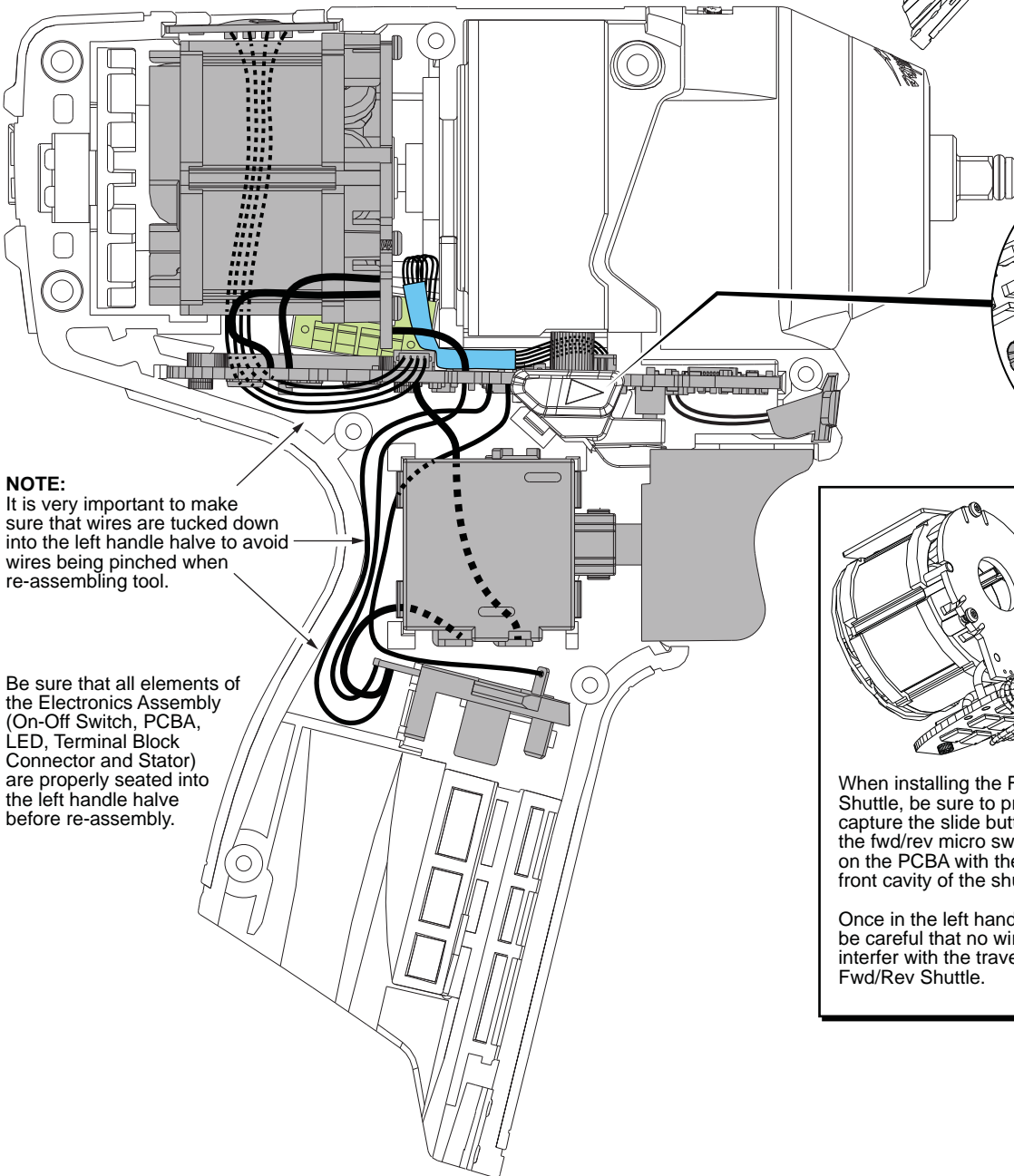
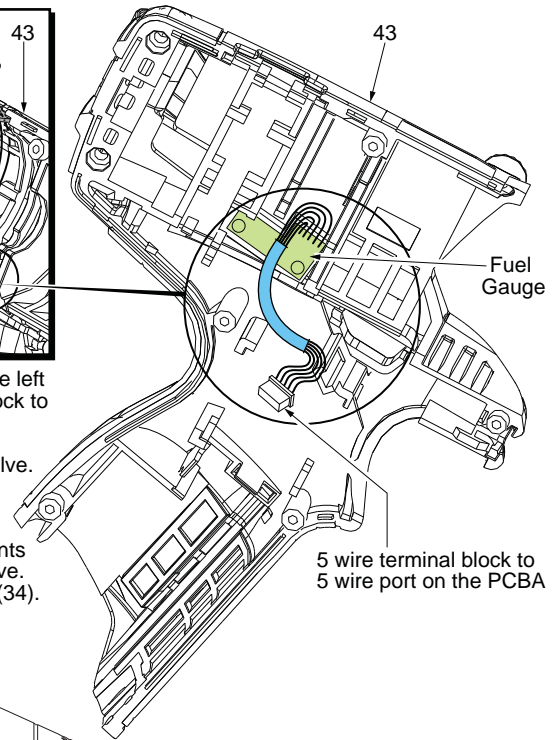

NOTE:
It is very important to make sure that wires are tucked down into the left handle half to avoid wires being pinched when re-assembling tool.

Be sure that all elements of the Electronics Assembly (On-Off Switch, PCBA, LED, Terminal Block Connector and Stator) are properly seated into the left handle half before re-assembly.

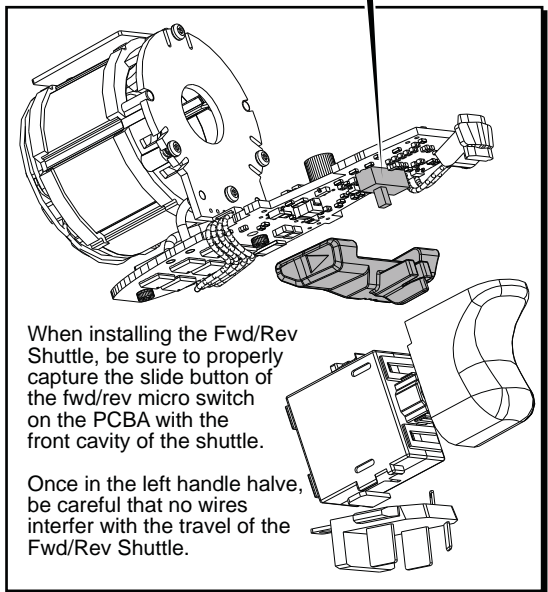

When installing the Fwd/Rev Shuttle, be sure to properly capture the slide button of the fwd/rev micro switch on the PCBA with the front cavity of the shuttle.

Once in the left handle half, be careful that no wires interfere with the travel of the Fwd/Rev Shuttle.