



SERVICE PARTS LIST

BULLETIN NO.
54-47-0200

SPECIFY CATALOG NO. AND SERIAL NO. WHEN ORDERING PARTS		REVISED BULLETIN	DATE
M12™ PEX Expander			June 2014
CATALOG NO. 2432-20	STARTING SERIAL NO. C62A	WIRING INSTRUCTION SEE PAGE 4	

EXAMPLE:
Component Parts (Small #) Are Included
When Ordering The Assembly (Large #).

The Gearcase Assembly (17) comes with a Motor Mount Bracket (31) that must be removed and discarded when servicing. A Motor Mount Bracket already exists on the Motor Assembly (34).

Original Design 42-70-0055
Improved Design 42-70-0058

M12™ tools utilize two different Housing Connection Clip designs depending on the Handle Set. See page two for details.

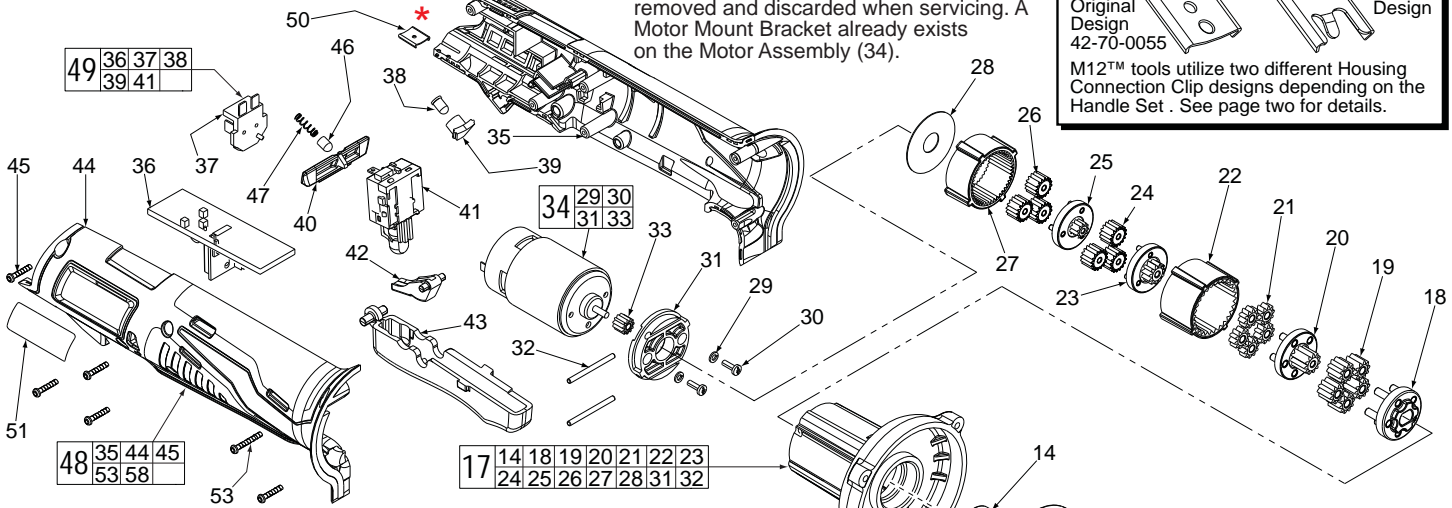

FIG.	PART NO.	DESCRIPTION OF PART	NO. REQ.
1	See Chart	Head Assembly (Optional, see chart)	(1)
1.1	-----	Segment	(6)
1.2	-----	Garter	(1)
1.3	-----	Ring	(1)
2	43-40-0950	Frame	(1)
3	34-40-1050	O-Ring	(1)
4	42-76-0950	Rotating Collar	(1)
5	40-50-1575	Collar Spring	(1)
6	44-60-1580	Pin	(1)
7	31-76-0300	Drive Collar	(1)
8	40-50-1035	Return Spring	(1)
9	32-75-1190	Spindle	(1)
10	44-96-0230	Roller	(1)
11	44-60-1585	Roller Pin	(1)
12	28-20-1390	Gearcase Cover Assembly	(1)
13	06-82-5320	8-32 x 5/8" Pan Hd. Stt. Tapt. T-20 Scr.	(2)
14	02-04-1005	Ball Bearing	(1)
15	36-10-0680	Cam and Shaft Assembly	(1)
17	28-14-2330	Gearcase Assembly	(1)
18	-----	4th Carrier	(1)
19	-----	4th Planet Gear	(5)
20	-----	4th Sun Gear	(1)
21	-----	3rd Planet Gear	(1)
22	-----	3rd and 4th Ring Gear	(5)
23	-----	3rd Sun Gear	(1)
24	-----	2nd Planet Gear	(3)
25	-----	2nd Sun Gear	(1)
26	-----	1st Planet Gear	(3)
27	-----	1st and 2nd Ring Gear	(1)
28	-----	Washer	(1)
29	05-90-0050	Spring Washer	(2)
30	05-81-0205	M3 x 6 Pan Hd. Motor Screw	(2)
31	42-36-0840	Motor Mount Bracket	(1)
32	44-60-1530	Motor Mount Pin	(2)
33	-----	Motor Pinion	(1)
34	23-30-0625	Motor Assembly	(1)
35	-----	Handle Halve - Left	(1)
36	-----	PCBA	(1)
37	-----	Connector Block	(1)
38	-----	LED	(1)
39	-----	LED Holder	(1)
40	31-76-0325	Shuttle	(1)
41	-----	Switch	(1)
42	44-10-0825	Trigger Lever	(1)
43	31-92-0570	Trigger	(1)
44	-----	Handle Halve - Right	(1)
45	06-82-1080	M3 x 14 Pan Hd. Plast. T-10 Screw	(5)
46	43-72-0430	Shuttle Detent	(1)
47	40-50-1475	Shuttle Detent Spring	(1)
48	31-44-2475	Handle Kit	(1)
49	23-66-2840	Switch Assembly	(1)
50	42-70-0055	Housing Connection Clip	(1)
51	12-20-2432	Service Nameplate	(1)
52	42-55-2400	Carrying Case, Optional	(1)
53	05-88-0675	M3 x 20 Pan Hd. Plast. T-10 Screw	(1)
54	06-82-5316	8-32 x 1/2" Pan Hd. Stt. Tapt. T-20 Scr.	(2)
55	43-74-0730	Belt Hook	(1)
56	02-04-1022	Ball Bearing	(1)
57	10-20-2002	Warning Label (Not Shown)	(1)
58	-----	Fuel Gauge Label (Not Shown)	(1)
59	45-88-1485	Flat Washer	(1)

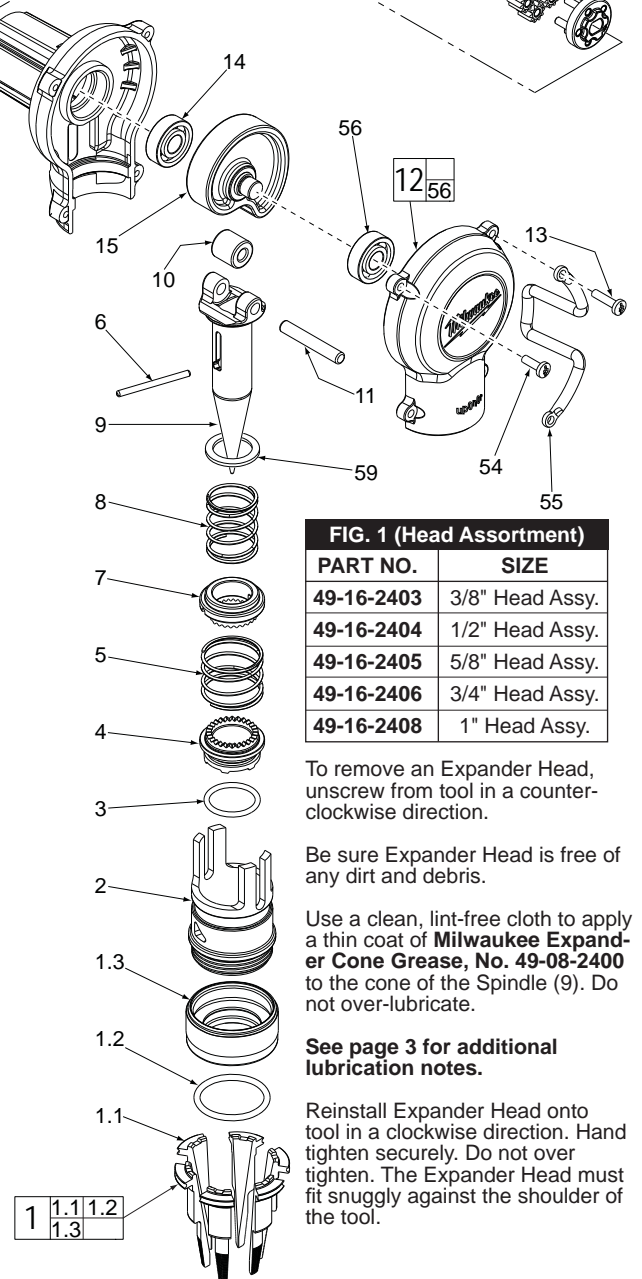

FIG. 1 (Head Assortment)

PART NO.	SIZE
49-16-2403	3/8" Head Assy.
49-16-2404	1/2" Head Assy.
49-16-2405	5/8" Head Assy.
49-16-2406	3/4" Head Assy.
49-16-2408	1" Head Assy.

To remove an Expander Head, unscrew from tool in a counter-clockwise direction.

Be sure Expander Head is free of any dirt and debris.

Use a clean, lint-free cloth to apply a thin coat of **Milwaukee Expander Cone Grease, No. 49-08-2400** to the cone of the Spindle (9). Do not over-lubricate.

See page 3 for additional lubrication notes.

Reinstall Expander Head onto tool in a clockwise direction. Hand tighten securely. Do not over tighten. The Expander Head must fit snugly against the shoulder of the tool.