



SERVICE PARTS LIST

BULLETIN NO.
55-24-2430

SPECIFY CATALOG NO. AND SERIAL NO. WHEN ORDERING PARTS		REVISED BULLETIN	DATE
M12 FUEL™ SDS Rotary Hammer			Apr. 2013
CATALOG NO. 2416-059	STARTING SERIAL NO. F02A	WIRING INSTRUCTION SEE PAGE 4	

EXAMPLE:
Component Parts (Small #) Are Included When Ordering The Assembly (Large #).

● = Component of the 14-46-2416 Service Maintenance Kit. See Page 2.

NOTE: Fuel Gauge #67 is hot melted into Support Housing #59. Fuel gauge is then plugged into PCBA #66.

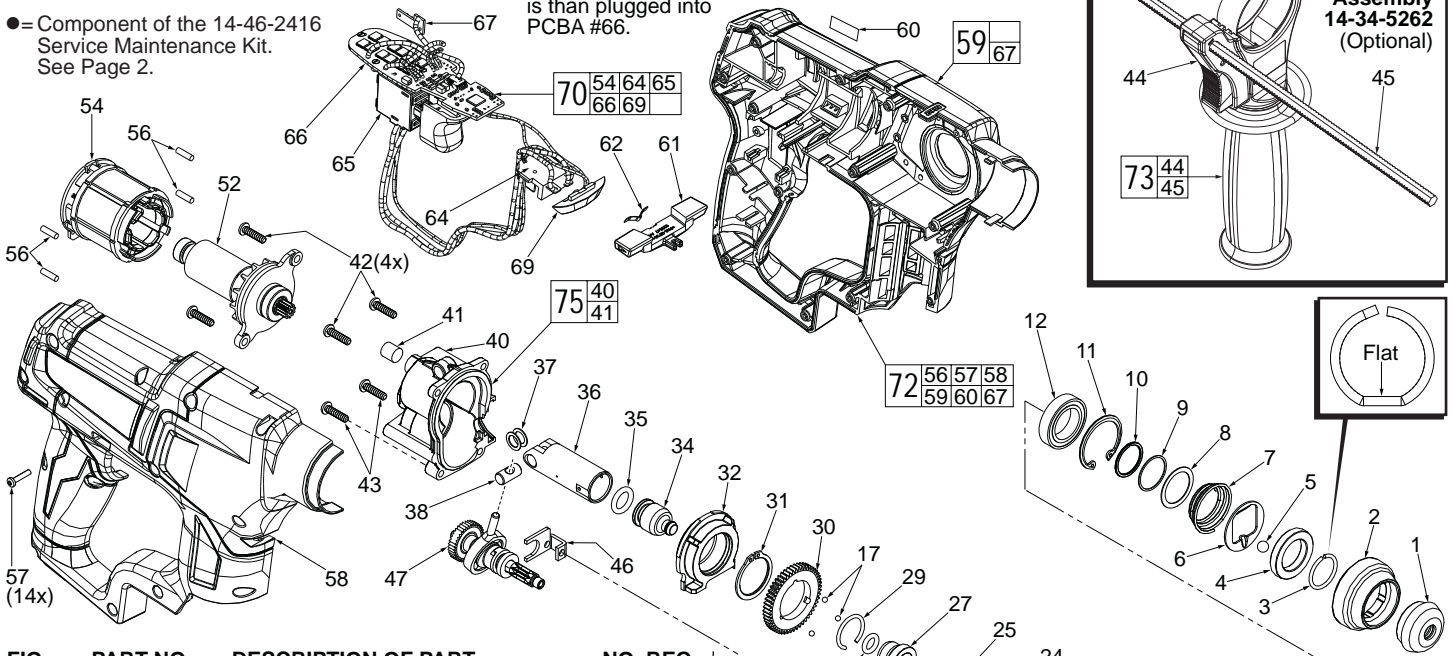
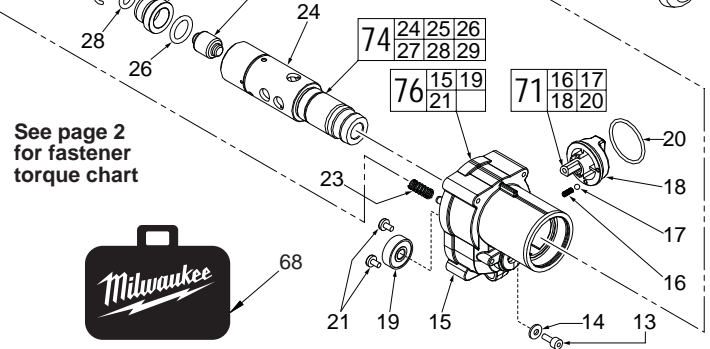

FIG.	PART NO.	DESCRIPTION OF PART	NO. REQ.
1	42-52-5262 ●	Cap	(1)
2	42-96-0035 ●	Sleeve	(1)
3	44-90-0106 ●	Snap Ring	(1)
4	44-90-0107	Holding Ring	(1)
5	02-02-0146 ●	6.5mm Steel	(1)
6	42-36-0039	Support Plate	(1)
7	40-50-5262	Pressure Spring	(1)
8	45-88-0226	Flat Washer	(1)
9	45-88-0227	Flat Washer	(1)
10	44-90-0108	Spiral Retaining Ring	(1)
11	34-80-0210	Retaining Ring	(1)
12	02-04-0315	Ball Bearing	(1)
13	05-84-0005 ●	M3 x 0.5mm x 8.0mm Socket Screw	(1)
14	45-88-0107 ●	Flat Washer	(1)
15	-----	Gearcase with Shift Pin	(1)
16	40-50-1220 ●	Spring	(1)
17	02-02-1230 ●	3.0 Steel Ball	(4)
18	44-10-0605	Shift Knob	(1)
19	02-04-0325	Ball Bearing	(1)
20	34-40-0533 ●	O-Ring	(1)
21	05-81-0020	M3.0 x 5 Pan Hd. ST Screw	(2)
23	40-50-1215	Shifter Spring	(1)
24	38-50-0420	Spindle	(1)
25	45-08-0505	Anvil	(1)
26	34-40-0530 ●	O-Ring	(1)
27	45-22-0008	Sleeve	(1)
28	34-40-0531 ●	O-Ring	(1)
29	44-90-0109 ●	Snap Ring	(1)
30	32-44-1130	2nd Stage Gear	(1)
31	34-60-0140	Retaining Ring	(1)
32	28-72-0035	Bearing Holder Assy. with Needle Bearing	(1)
34	45-56-0025	Striker (Ram)	(1)
35	34-40-0532 ●	O-Ring	(1)
36	44-62-0147	Piston	(1)
37	45-88-0228 ●	Wrist Washer	(2)
38	44-60-0555	Wrist Pin	(1)
39	10-20-1341	Warning Label (Not Shown)	(1)
40	-----	Rear Gearcase	(1)
41	43-84-0300 ●	Felt Plug	(1)
42	05-74-0010	M4 x 16mm Pan Hd. T-20 Screw	(4)
43	05-74-0012	M4 x 20 Screw	(2)
44	14-34-0650	Auxiliary Side Handle (Optional)	(1)
45	44-94-5381	Depth Rod (Optional)	(1)
46	44-66-0405	Shifting Clip	(1)
47	36-92-0300	Wobble Shaft Assembly	(1)
52	14-50-0050	Rotor Assembly	(1)
54	-----	Stator	(1)
56	45-30-0270	Rubber Slugs	(4)
57	06-82-2385	M3 x 14mm Pan Hd. Plastite T-10 Screw	(14)



See page 2 for fastener torque chart

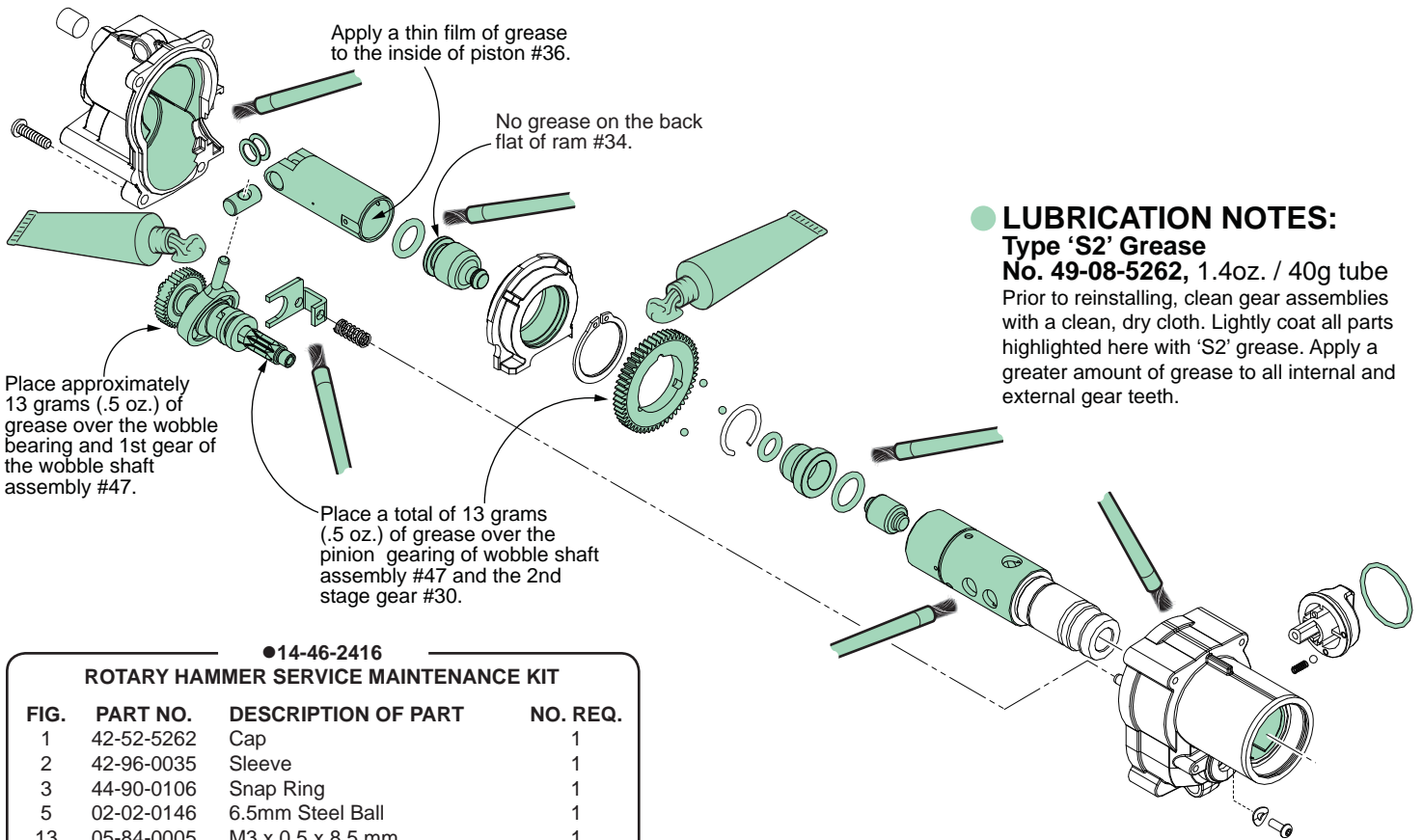

FIG.	PART NO.	DESCRIPTION OF PART	NO. REQ.
58	-----	Cover Housing	(1)
59	-----	Support Housing with Fuel Gauge	(1)
60	10-20-0304	Fuel Gauge Label	(1)
61	42-42-0185	Forward / Reverse Shuttle	(1)
62	40-50-1135	Shuttle Spring	(1)
63	-----	Service Nameplate (Not Shown)	(1)
64	-----	Contact Plate Holder	(1)
65	-----	Switch	(1)
66	-----	PCB Assembly	(1)
67	-----	Fuel Gauge	(1)
68	42-55-2416	Carrying Case	(1)
69	-----	LED Lens	(1)
70	23-66-2416	Switch / Electronics Assembly	(1)
71	44-10-0610	Shift Knob Assembly	(1)
72	14-34-0620	Handle Housing Assy. with Fuel Gauge	(1)
73	14-34-5262	Side Handle Assembly (Optional)	(1)
74	38-50-0425	Spindle Assembly	(1)
75	14-30-0070	Rear Gearcase Assy. with Needle Bearing	(1)
76	14-30-0066	Front Gearcase Assembly	(1)

FIG. 3,24 NOTE:
There is a 'flat' that is opposite the opening on the snap ring. Align 'flat' on snap ring with 'flat' on spindle.

5,6 Position ball notch on support plate and ball towards 'flats'.

13 Apply a drop of Blue Loctite® 242 or the equivalent to the threads of screw prior to installing in front gearcase.



LUBRICATION NOTES:

Type 'S2' Grease

No. 49-08-5262, 1.4oz. / 40g tube
 Prior to reinstalling, clean gear assemblies with a clean, dry cloth. Lightly coat all parts highlighted here with 'S2' grease. Apply a greater amount of grease to all internal and external gear teeth.

●14-46-2416

ROTARY HAMMER SERVICE MAINTENANCE KIT

FIG.	PART NO.	DESCRIPTION OF PART	NO. REQ.
1	42-52-5262	Cap	1
2	42-96-0035	Sleeve	1
3	44-90-0106	Snap Ring	1
5	02-02-0146	6.5mm Steel Ball	1
13	05-84-0005	M3 x 0.5 x 8.5 mm	1
14	45-88-0107	Flat Washer	1
16	40-50-1220	Spring	1
17	02-02-1230	3.0 Steel Ball	1
20	34-40-0533	O-Ring	1
26	34-40-0530	O-Ring	1
28	34-40-0531	O-Ring	1
29	44-90-0109	Snap Ring	1
35	34-40-0532	O-Ring	1
37	45-88-0228	Wrist Pin Washer	2
41	43-84-0300	Felt Plug	1
-	49-08-5262	1.4 oz. / 40gr. Tube 'S 2' Grease	1

SCREW TORQUE SPECIFICATIONS

FIG.	PART NO.	WHERE USED	SEAT TORQUE	
			(KG/CM)	(IN/LBS)
13	05-81-0005	Gearcase (Bottom)	15-19	13-16
21	05-81-0020	Ball Bearing Retainers	8-12	7-10
42	05-74-0010	Rear Gearcase (Top)	12-17	10-14
42	05-74-0010	Motor Mounting Plate	12-17	10-14
43	05-74-0012	Rear Gearcase (Bottom)	12-17	10-14
57	06-82-2385	Cover Housing	8-10	7-8

NOTE:

As an aid to installing items #25, #26, #27 and #28 squarely into spindle #24, the following steps should be followed:

1. Place o-ring #28 inside sleeve #27.
2. Place anvil #25 inside sleeve #27.
3. Slide o-ring #26 onto anvil #25.
4. Place that assembly of parts on top of an old piston #36 and gently insert into the back end of spindle #24 until parts bottom out. Remove piston.

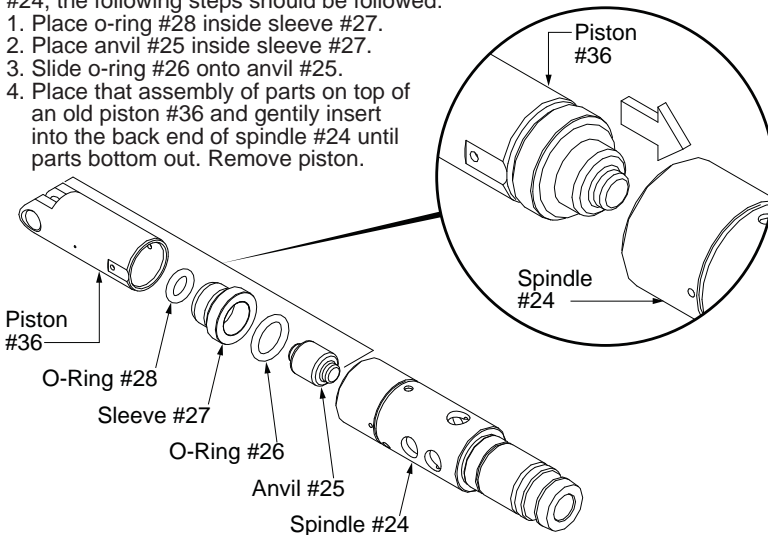

NOTE:

As an aid to installing snap ring #29 into spindle #24, rest the snap ring on rear spindle, perpendicular to the opening. To condense the snap ring, use a flat blade screwdriver to push snap ring down into the spindle cavity. Push the snap ring past the shoulder in the spindle before rotating the snap ring in the cavity. Press snap ring into the retaining slot, securing items 25, 26, 27 and 28.

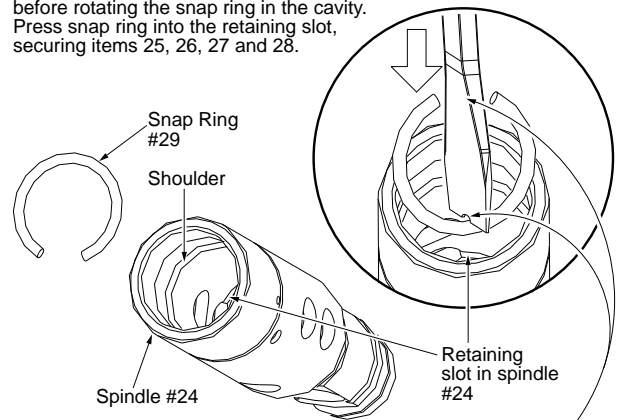

NOTE:

As an aid to installing snap ring, it may be helpful to file or grind a notch in the bottom flat of the screwdriver to accommodate the round of the snap ring. As force is applied to the snap ring, the open end of the ring will close in on the screwdriver. It may be necessary to do additional modifications to the screwdriver (grinding the sides of the blade or shaft) to allow for the insertion of the ring and the removal of the screwdriver.

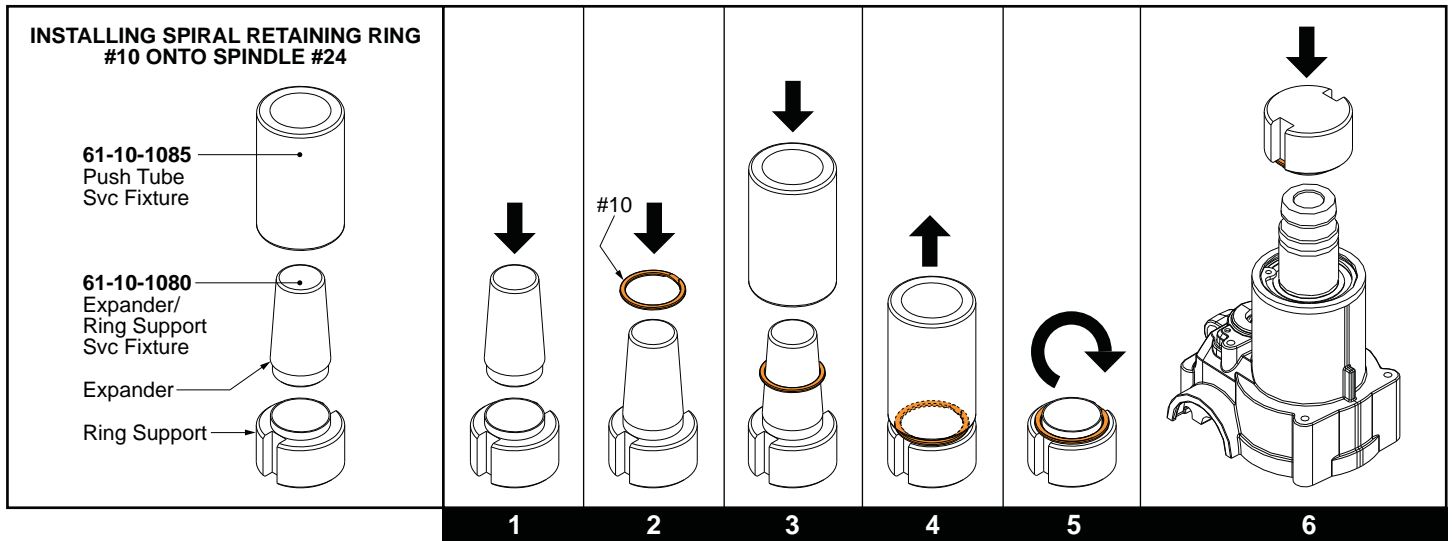

1. Assemble Expander/Ring Support Service Fixture (61-10-1080) by inserting the expander into the ring support as shown.
2. Place the assembled fixture on a flat, level surface. Place the Spiral Retaining Ring #10 squarely onto tapered end of the expander.
3. Place the Push Tube Service Fixture (61-10-1085) over the expander until it rests against the spiral retaining ring. With the use of a mallet, drive the push tube and spiral retaining ring down onto the ring support.
4. Remove the push tube. The spiral retaining ring has been expanded around the collar of the ring support.
5. Turn the ring support/spiral snap ring upside down.
6. Place the ring support/spiral snap ring over the top of spindle #24.

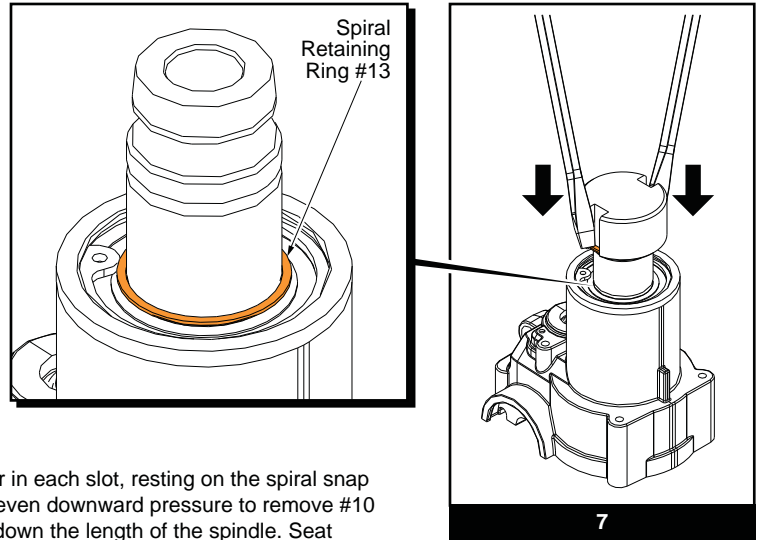

7. Locate the two slots on the ring support. Place a flat blade screwdriver in each slot, resting on the spiral snap ring. (It is preferred that the same size screwdrivers are used). Place even downward pressure to remove #10 off of the ring support and onto the spindle. Slide the spiral snap ring down the length of the spindle. Seat squarely into groove of spindle as shown.

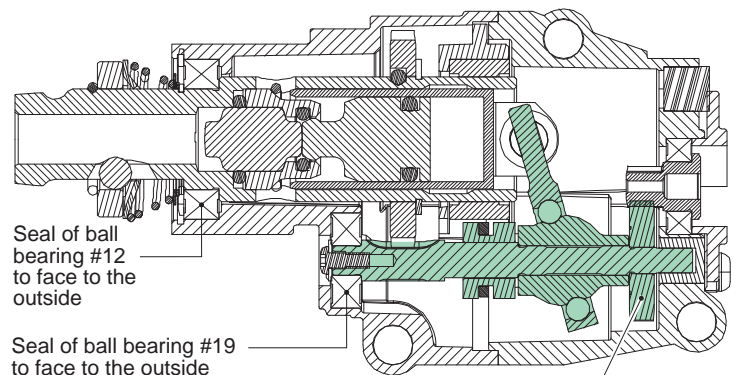
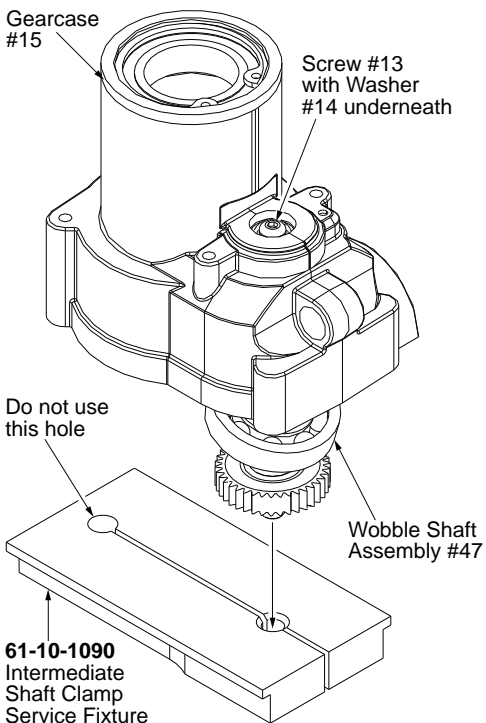

DO NOT attempt to service or modify any individual component of wobble shaft assembly #47. **DO NOT** press apart or change the seating of the gear.

To properly assemble the wobble shaft assembly #47 to the gearcase #15, the Intermediate Shaft Service Fixture (61-10-1090) will be needed.

Orient the service fixture as shown. Loosely place the service fixture in the jaws of a bench vise with the lip of the fixture riding on top of the vise.

Insert the narrow shaft end of the wobble shaft assembly through ball bearing #19 (not shown) inside the gearcase. Temporarily secure the wobble shaft assembly to the gearcase using washer #14 and screw #13). Hand tighten.

Place the wobble shaft into the hole of the service fixture as shown. Tighten the jaws of the bench vise to secure the service fixture around the intermediate shaft.

After the proper torque value is applied to screw #13 (**13-16 in/lbs or 15-19 kg/cm**), remove the gearcase/wobble shaft assembly from the service fixture.

● = WIRE TRAPS
or GUIDES

