



# SERVICE PARTS LIST

**BULLETIN NO.**  
**54-06-2370**

SPECIFY CATALOG NO. AND SERIAL NO. WHEN ORDERING PARTS		REVISED BULLETIN	DATE
CORDLESS M18™ 360° Lantern			June 2014
CATALOG NO.	2363-20	STARTING SERIAL NO.	G25A
WIRING INSTRUCTION			

**EXAMPLE:**  
Component Parts (Small #) Are Included  
When Ordering The Assembly (Large #).

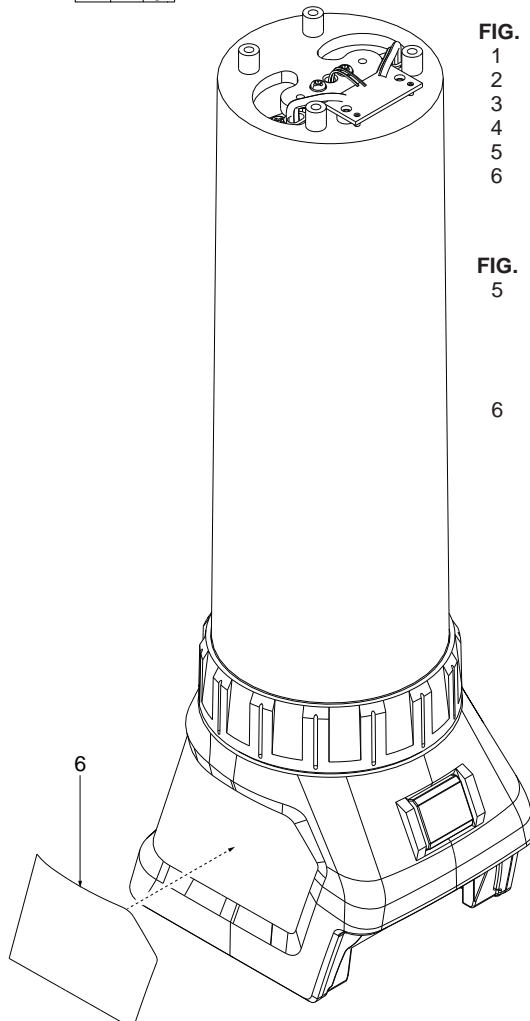
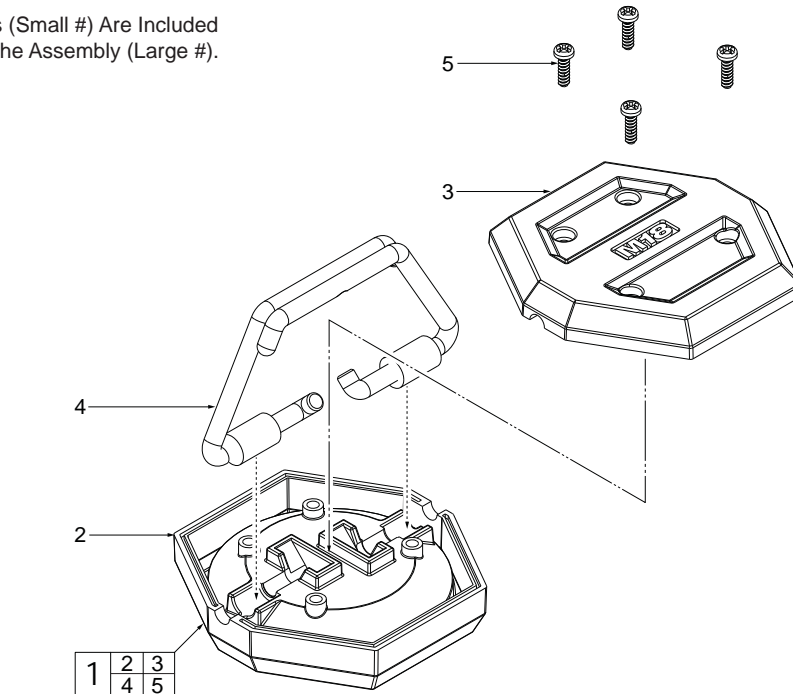

FIG.	PART NO.	DESCRIPTION OF PART	NO. REQ.
1	14-36-2363	Cap / Hook Assembly	(1)
2	-----	Cap	(1)
3	-----	Cover	(1)
4	-----	Hook Assembly	(2)
5	-----	M4 x 12mm Pan Hd. T-10 Screw	(4)
6	12-20-2367	Service Nameplate	(1)

- FIG. NOTES**
- 5 Care must be used when securing fasteners in tool. To prevent stripping do not over tighten. It is not recommended to use power tools, hand tighten only. Torque screws #4 to 5-7 in/lbs (6-8 kg/cm). Torque screws #10 to 3-4 in/lbs (3.5-4.5 kg/cm).
  - 6 A clean, dry surface is essential for proper performance for any adhesive system. The area intended for application of any adhesive label or nameplate must be prepared by cleaning with isopropyl alcohol. The solvent is to be applied with a clean, lint free applicator and the surface allowed to dry before applying the label or nameplate.