



# SERVICE PARTS LIST

**BULLETIN NO.**  
**54-07-2290**

SPECIFY CATALOG NO. AND SERIAL NO. WHEN ORDERING PARTS			REVISED BULLETIN	DATE
<b>12 VOLT POWER PORT</b>				Jan. 2009
<b>CATALOG NO.</b>	<b>2349-20</b>	<b>SERIAL NUMBER</b>	<b>C01A</b>	
			WIRING INSTRUCTION	

**EXAMPLE:**  
Component Parts (Small #)  
Are Included When Ordering  
The Assembly (Large #).

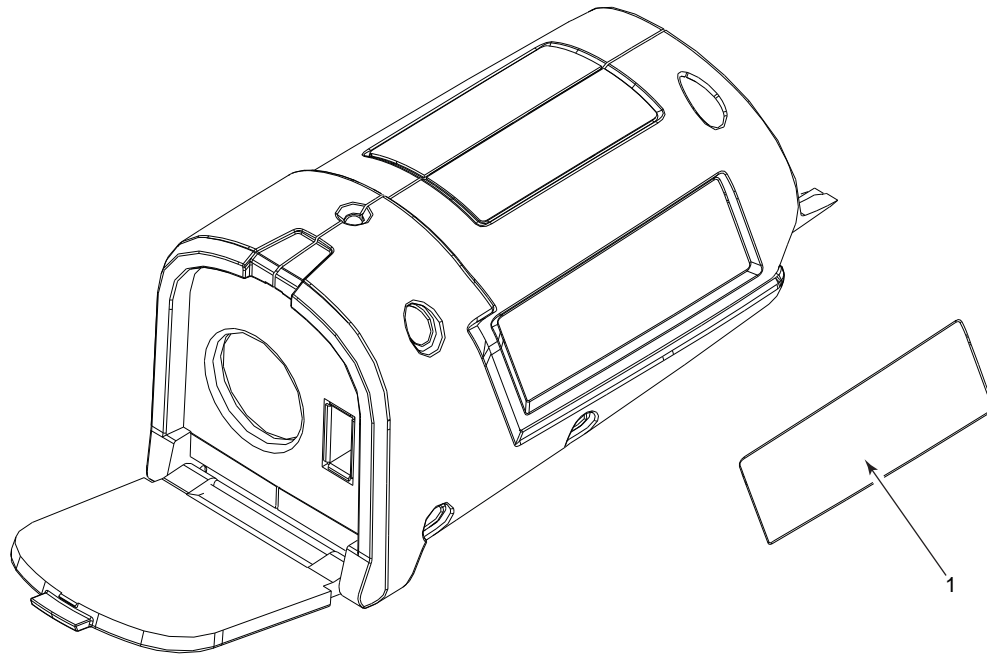
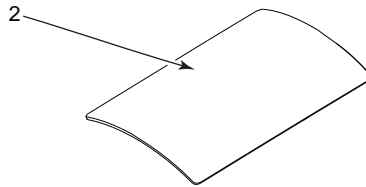

FIG.	PART NO.	DESCRIPTION OF PART	NO. REQ.
1	12-20-2349	Service Nameplate	(1)
2	10-20-1682	Warning Label	(1)

**FIG. NOTES**  
1, 2 A clean, dry surface is essential for proper performance for any adhesive system. The area intended for application of any adhesive label or nameplate must be prepared by cleaning with isopropyl alcohol. The solvent is to be applied with a clean, lint free applicator and the surface allowed to dry before applying the label or name plate.