



SERVICE PARTS LIST

BULLETIN NO.
54-30-0100

SPECIFY CATALOG NO. AND SERIAL NO. WHEN ORDERING PARTS		REVISED BULLETIN	DATE
MAG STAND CONTROL PANEL			May '82
CATALOG NO. 23-35-0051	STARTING SERIAL NO.	WIRING INSTRUCTION 115V 58-01-0910 230V 58-01-0915	

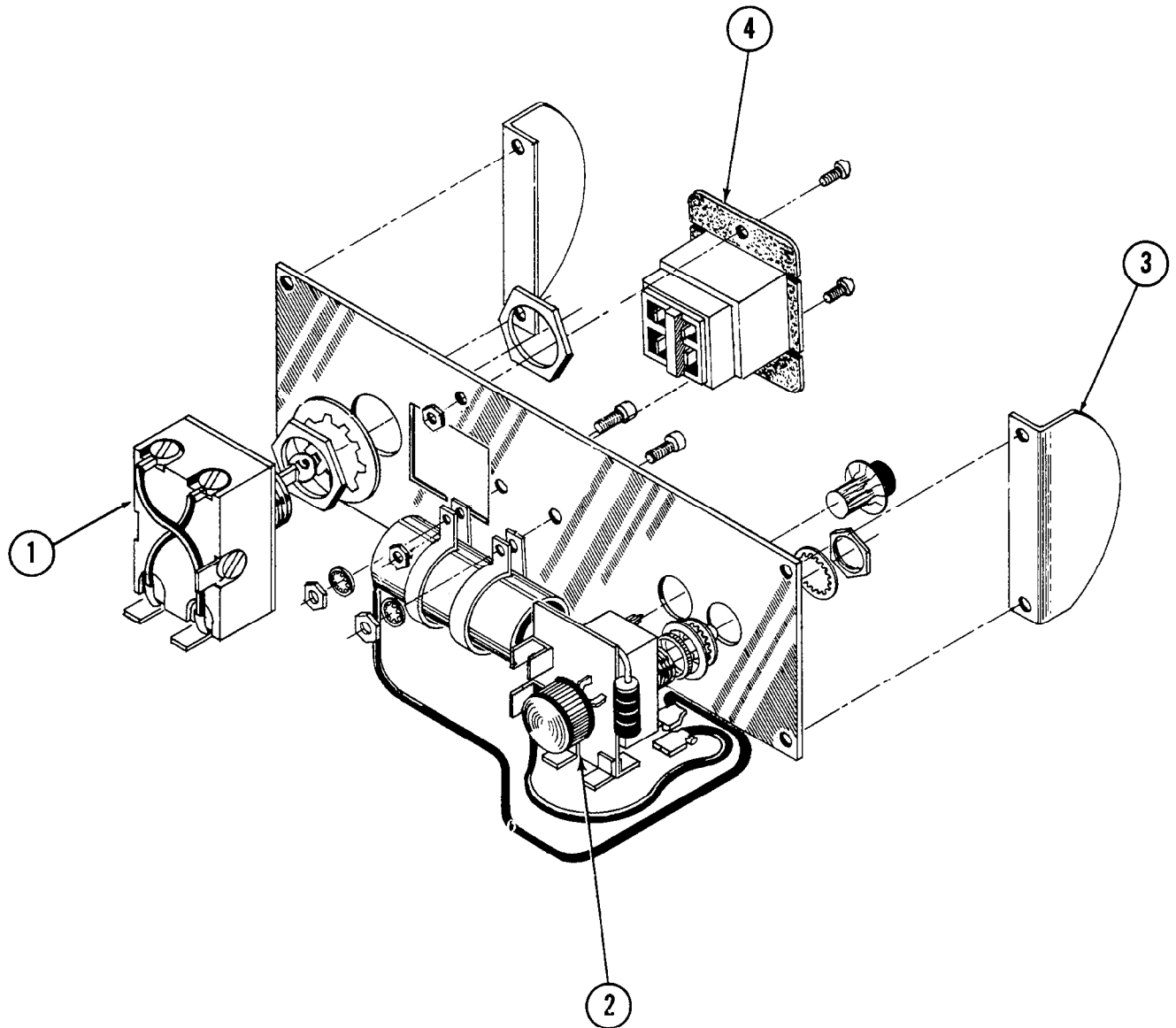

FIG.	PART NO.	DESCRIPTION OF PART	NO. REQ.
1	23-66-0340	Switch (With Fasteners)	
2	14-46-0380	Control Assembly	
3	43-54-0170	Panel Guard	(2)
4	23-33-0170	Receptacle	