

ILLUSTRATED PARTS LIST

MODEL NUMBER 1830SB

PRODUCT NUMBER 961 93 00-50

MFG. ID. NUMBER 96193005000

REPAIR PARTS

AUGER HOUSING / IMPELLER ASSEMBLY

SNOW THROWER - MODEL NO. 1830SB (96193005000), PRODUCT NO. 961 93 00-50

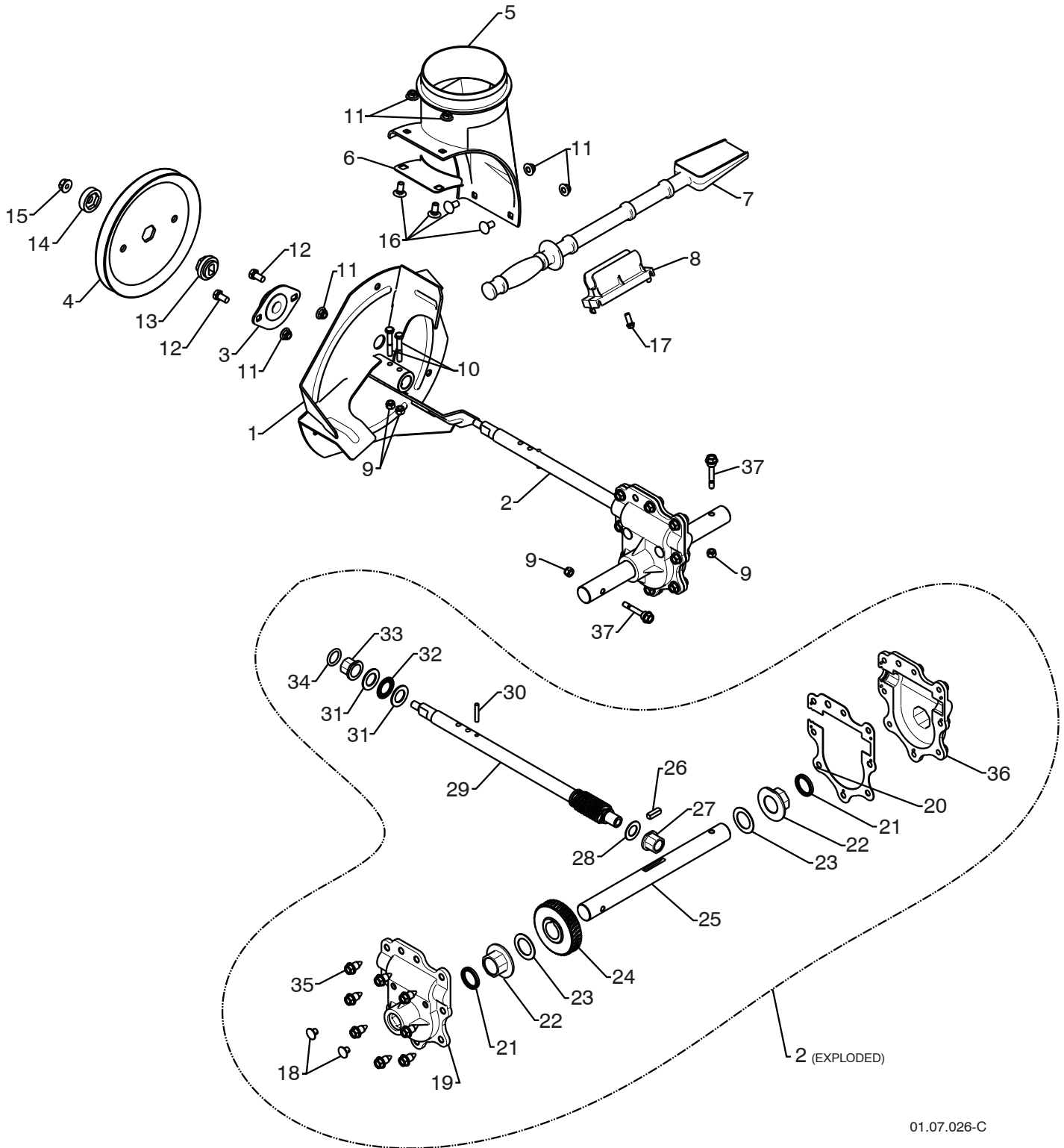

01.07.026-C

NOTE: All component dimensions given in U.S. inches. 1 inch = 25.4 mm
IMPORTANT: Use only Original Equipment Manufacturer (O.E.M.) replacement parts. Failure to do so could be hazardous, damage your snow thrower and void your warranty.

REPAIR PARTS**AUGER HOUSING / IMPELLER ASSEMBLY****SNOW THROWER - MODEL NO. 1830SB (96193005000), PRODUCT NO. 961 93 00-50**

KEY NO.	PART NO.	DESCRIPTION
1	532 18 41-05	IMPELLER
2	532 42 71-48	GEARBOX ASSEMBLY
3	532 18 89-09	BEARING
4	532 42 71-46	IMPELLER PULLEY
5	532 17 53-22	DISCHARGE BASE
6	532 18 40-95	CORNER BRACKET
7	532 19 21-99	CLEAN OUT TOOL
8	532 40 54-00	TOOL CLIP
9	873 80 04-00	NUT 1/4-20
10	874 78 04-26	SCREW 1/4-20 X .625
11	532 42 79-42	NUT 5/16-18
12	532 16 31-83	SCREW 5/16-18 X .625
13	532 42 71-45	IMPELLER HUB
14	532 42 71-54	IMPELLER SLEEVE
15	873 90 06-00	NUT 3/8-16
16	532 18 03-55	CARRIAGE BOLT
17	532 19 41-89	SCREW 13-16 X .625
18	532 40 77-60	PLUG
19	532 42 73-02	GEARBOX COVER RH
20	532 42 73-45	GASKET
21	532 40 77-70	SEAL
22	532 40 77-62	BEARING
23	532 17 46-97	THRUST WASHER 1.00
24	532 40 77-63	WORM GEAR
25	532 40 77-64	AUGER SHAFT
26	532 18 92-82	SQUARE KEY
27	532 40 77-58	BEARING
28	532 17 46-83	THRUST WASHER
29	532 42 71-47	IMPELLER SHAFT
30	532 18 42-05	ROLL PIN
31	532 17 46-81	THRUST WASHER
32	532 17 46-84	THRUST BEARING
33	532 40 77-69	BEARING
34	532 40 77-68	O-RING
35	532 40 77-67	SCREW 5/16-18 X .750
36	532 42 73-17	GEARBOX COVER LH
37	532 19 20-90	SHEAR BOLT

NOTE: All component dimensions given in U.S. inches. 1 inch = 25.4 mm
IMPORTANT: Use only Original Equipment Manufacturer (O.E.M.) replacement parts.
Failure to do so could be hazardous, damage your snow thrower and void your warranty.

REPAIR PARTS

AUGER HOUSING / IMPELLER ASSEMBLY

SNOW THROWER - MODEL NO. 1830SB (96193005000), PRODUCT NO. 961 93 00-50

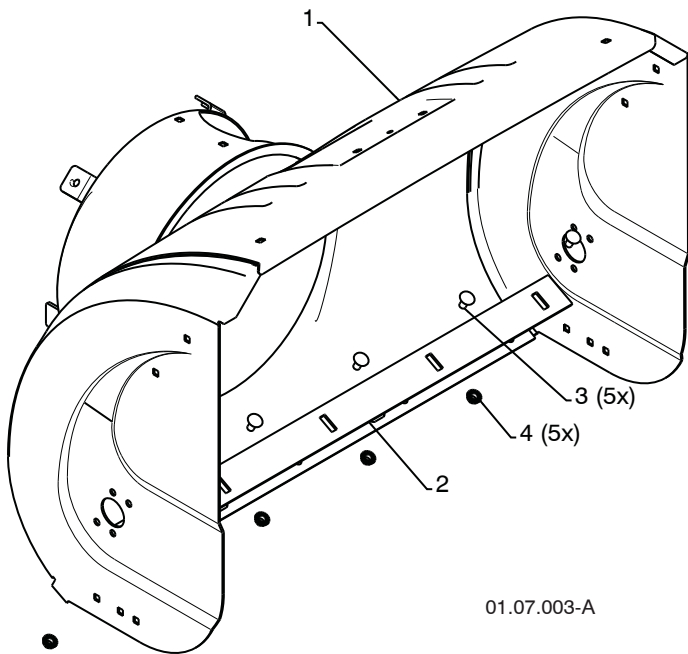

01.07.003-A

KEY NO.	PART NO.	DESCRIPTION
1	532 41 77-07	AUGER HOUSING
2	532 40 76-45	SCRAPPER BAR
3	872 27 05-05	CARRIAGEBOLT 5/16-18X.625
4	532 15 53-77	NUT 5/16-18

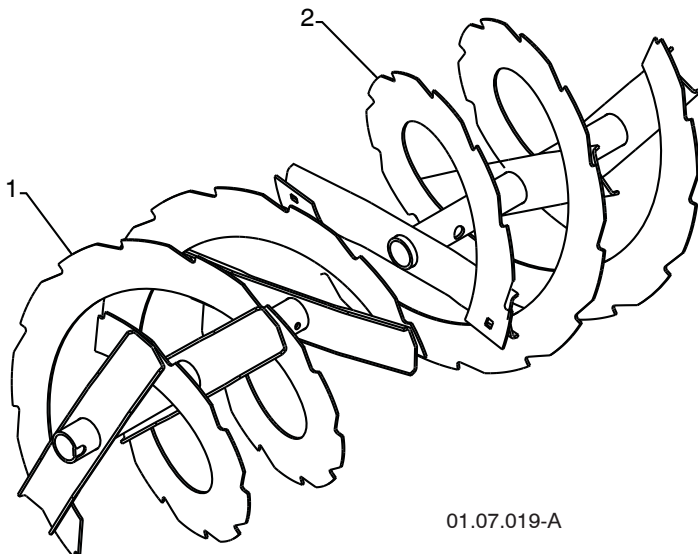

01.07.019-A

KEY NO.	PART NO.	DESCRIPTION
1	532 42 11-24	AUGER ASSEMBLY 30 LH
2	532 42 11-25	AUGER ASSEMBLY 30 RH

NOTE: All component dimensions given in U.S. inches. 1 inch = 25.4 mm
IMPORTANT: Use only Original Equipment Manufacturer (O.E.M.) replacement parts.
 Failure to do so could be hazardous, damage your snow thrower and void your warranty.

REPAIR PARTS

AUGER HOUSING / IMPELLER ASSEMBLY

SNOW THROWER - MODEL NO. 1830SB (96193005000), PRODUCT NO. 961 93 00-50

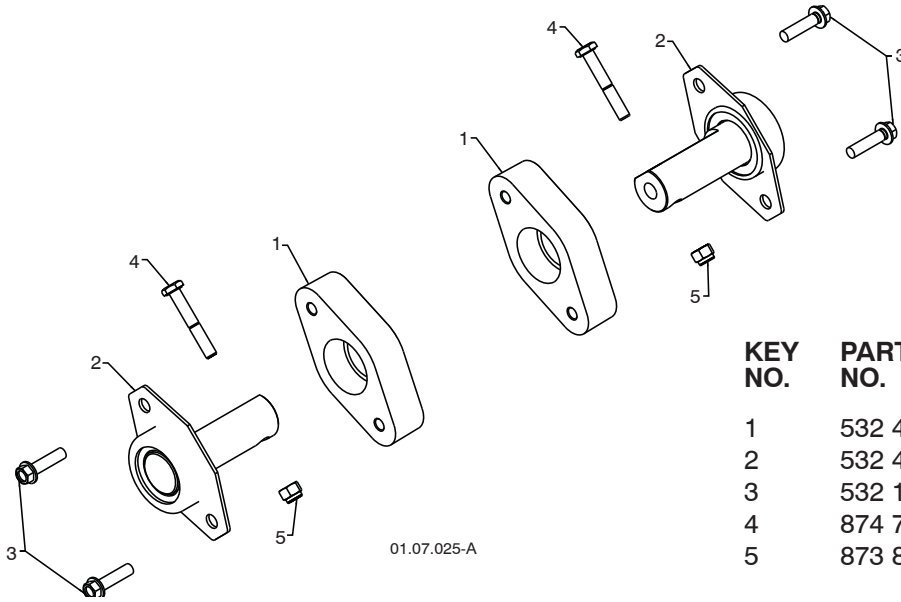

01.07.025-A

KEY NO.	PART NO.	DESCRIPTION
1	532 42 40-20	PLASTIC RETAINER
2	532 42 77-62	AUGER BALL BEARING
3	532 17 95-82	SCREW 5/16-18 X 1.00
4	874 78 04-26	SCREW 1/4-20 X .625
5	873 80 04-00	NUT 1/4-20

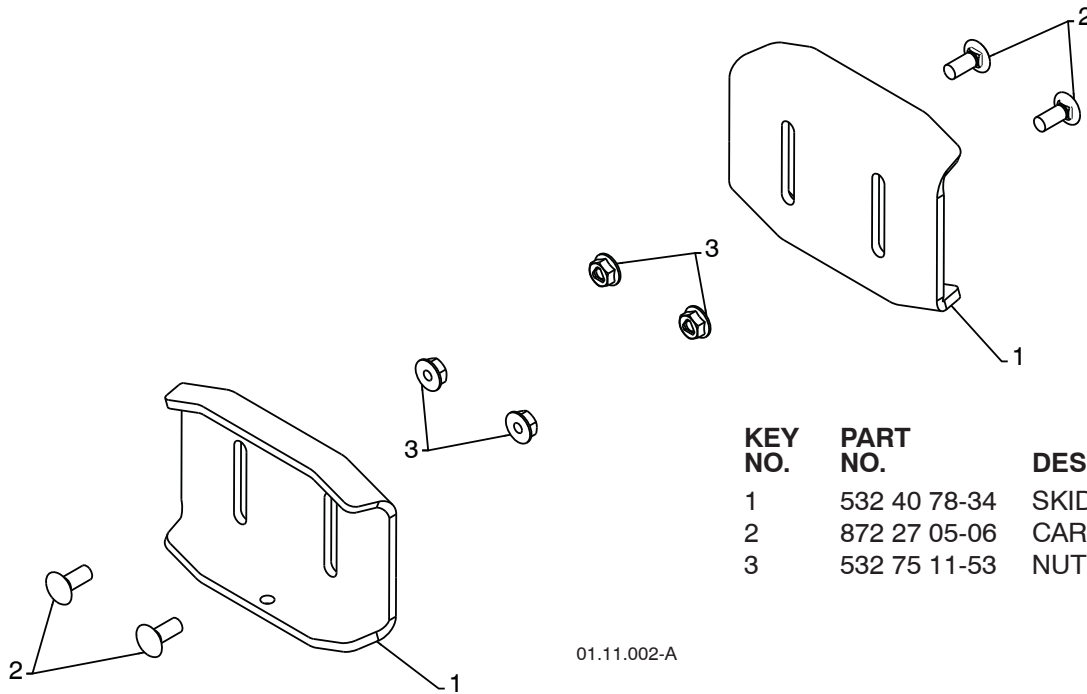

01.11.002-A

KEY NO.	PART NO.	DESCRIPTION
1	532 40 78-34	SKID PLATE
2	872 27 05-06	CARRIAGE BOLT 5/16-18 X .750
3	532 75 11-53	NUT 5/16-18

NOTE: All component dimensions given in U.S. inches. 1 inch = 25.4 mm
IMPORTANT: Use only Original Equipment Manufacturer (O.E.M.) replacement parts.
 Failure to do so could be hazardous, damage your snow thrower and void your warranty.

REPAIR PARTS

CONTROL PANEL / DISCHARGE CHUTE

SNOW THROWER - MODEL NO. 1830SB (96193005000), PRODUCT NO. 961 93 00-50

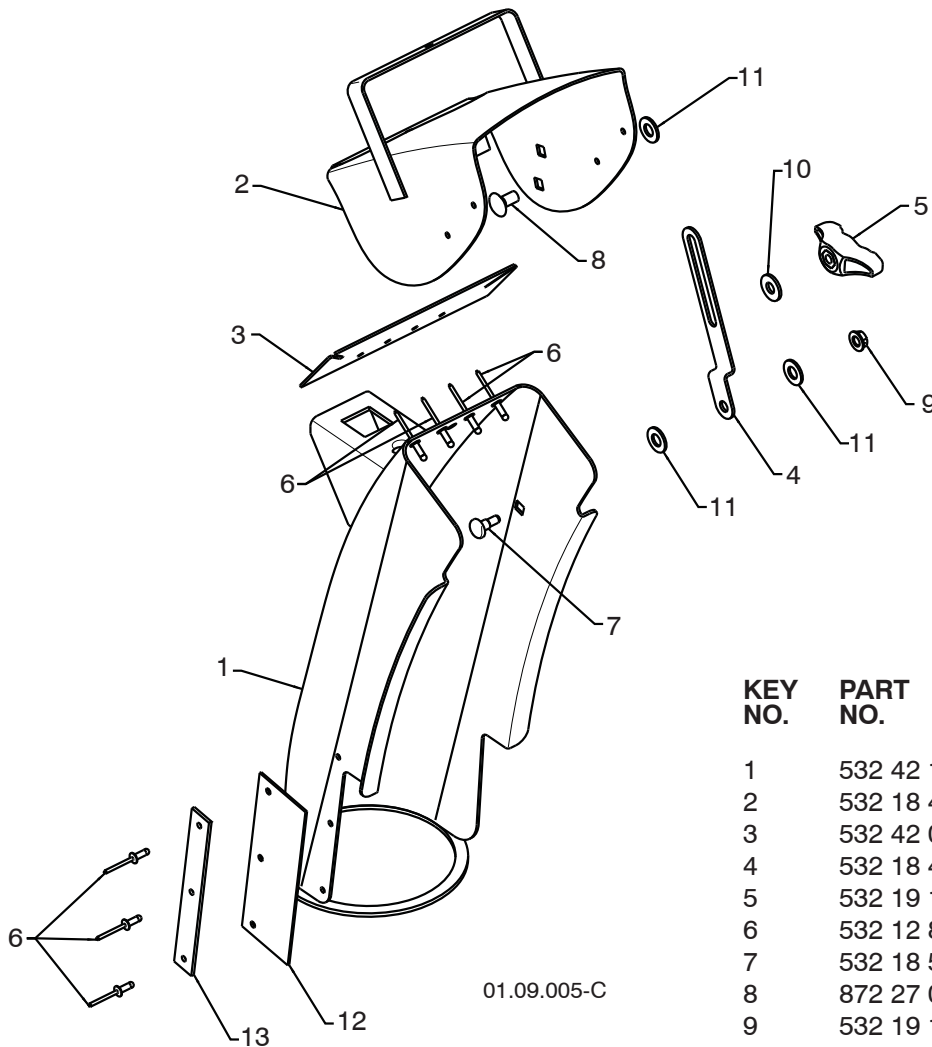

KEY NO.	PART NO.	DESCRIPTION
1	532 42 17-14	CHUTE WELDMENT
2	532 18 41-13	DEFLECTOR WELDMENT
3	532 42 03-25	DEFLECTOR SEAL
4	532 18 41-14	STRAP
5	532 19 19-38	KNOB BLACK
6	532 12 84-15	POP RIVET
7	532 18 56-00	SHOULDER BOLT 1/4-20 X .704
8	872 27 05-05	CARRIAGE BOLT 5/16-18 X .625
9	532 19 17-30	NUT 1/4-20
10	532 15 54-15	WASHER
11	532 17 92-46	PLASTIC WASHER
12	532 41 98-21	CHUTE SNOW SHIELD
13	532 42 17-28	SHIELD RETAINER STRAP

NOTE: All component dimensions given in U.S. inches. 1 inch = 25.4 mm
IMPORTANT: Use only Original Equipment Manufacturer (O.E.M.) replacement parts. Failure to do so could be hazardous, damage your snow thrower and void your warranty.

REPAIR PARTS

CONTROL PANEL / DISCHARGE CHUTE

SNOW THROWER - MODEL NO. 1830SB (96193005000), PRODUCT NO. 961 93 00-50

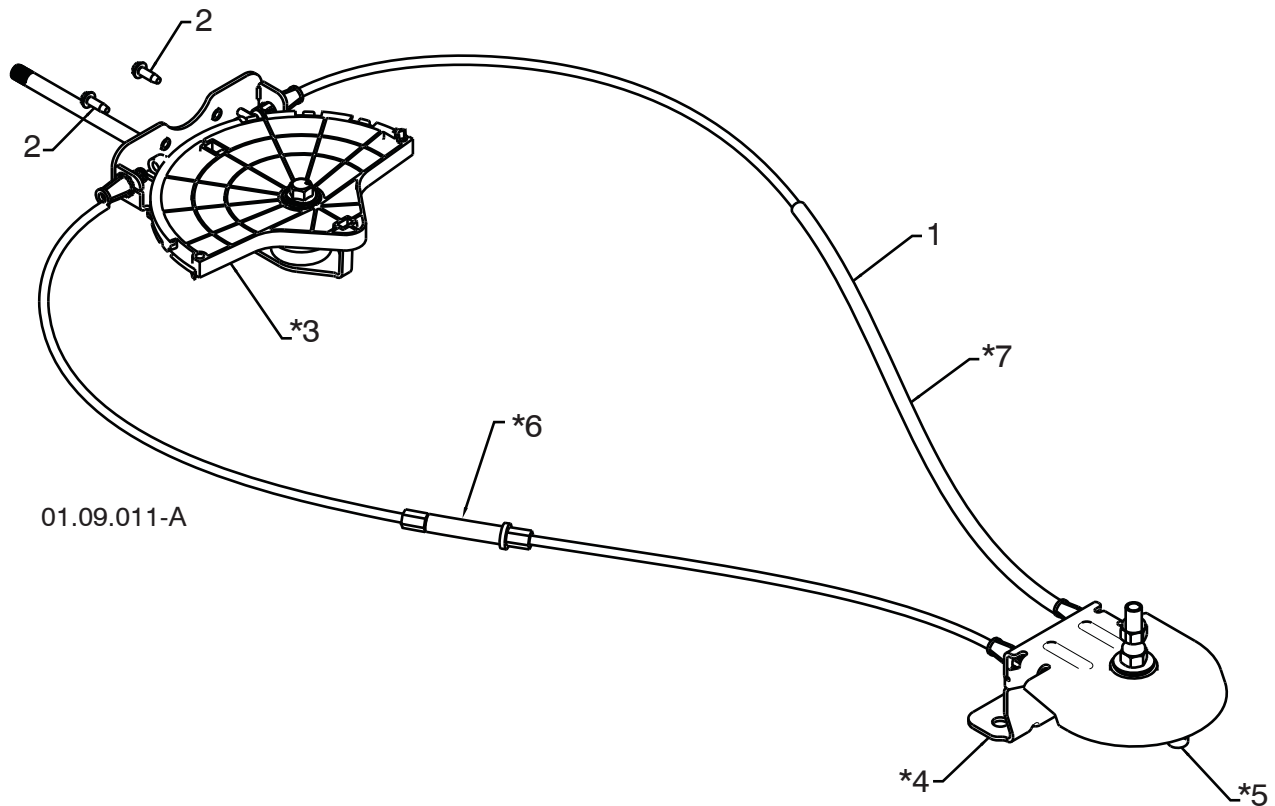

KEY NO.	PART NO.	DESCRIPTION
1	532 42 82-74	LEVER/CABLE ROTATOR ASSEMBLY
2	817 50 10-10	SCREW 10-24 X .625
*3	532 42 06-78	ROTATOR HEAD
*4	532 42 28-23	ROTATOR PIVOT BRACKET
*5	532 42 06-75	PULLEY PIVOT
*6	532 42 82-75	CABLE ASSEMBLY ADJUSTABLE GRAY
*7	532 42 83-11	CABLE ASSEMBLY HEAT SHIELD GRAY

NOTES:

1. ITEMS INDICATED WITH AN * ARE LISTED AS REFERENCE FOR SERVICE PARTS ONLY.

NOTE: All component dimensions given in U.S. inches. 1 inch = 25.4 mm
IMPORTANT: Use only Original Equipment Manufacturer (O.E.M.) replacement parts. Failure to do so could be hazardous, damage your snow thrower and void your warranty.

REPAIR PARTS

HANDLES

SNOW THROWER - MODEL NO. 1830SB (96193005000), PRODUCT NO. 961 93 00-50

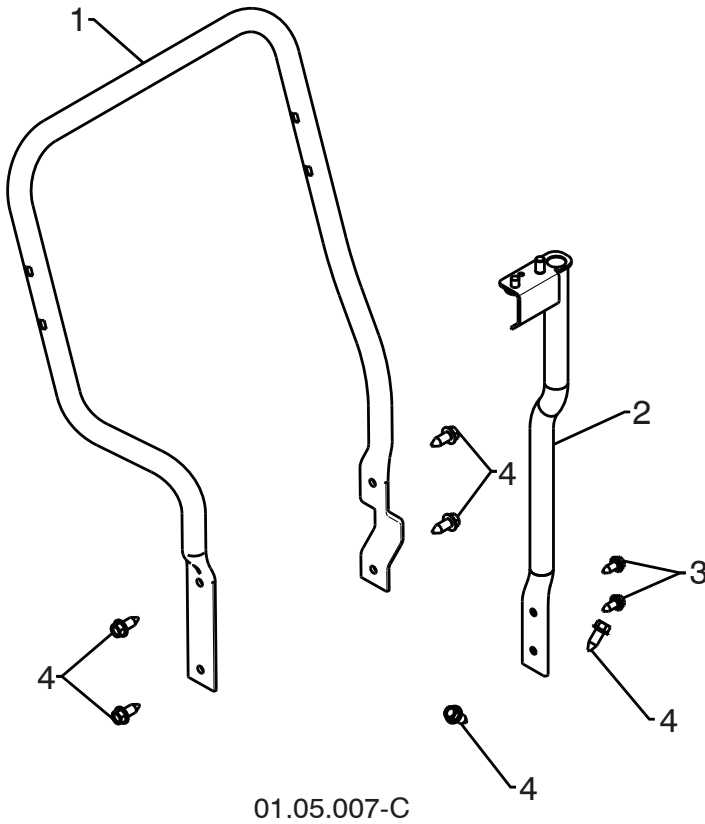

01.05.007-C

KEY NO.	PART NO.	DESCRIPTION
1	532 42 17-05	LOWER TUBE GRAY
2	532 42 21-17	PIVOT SUPPORT
3	532 42 88-67	BOLT 5/16-18 X .750
4	817 00 06-16	SCREW 3/8-16 X 1.00

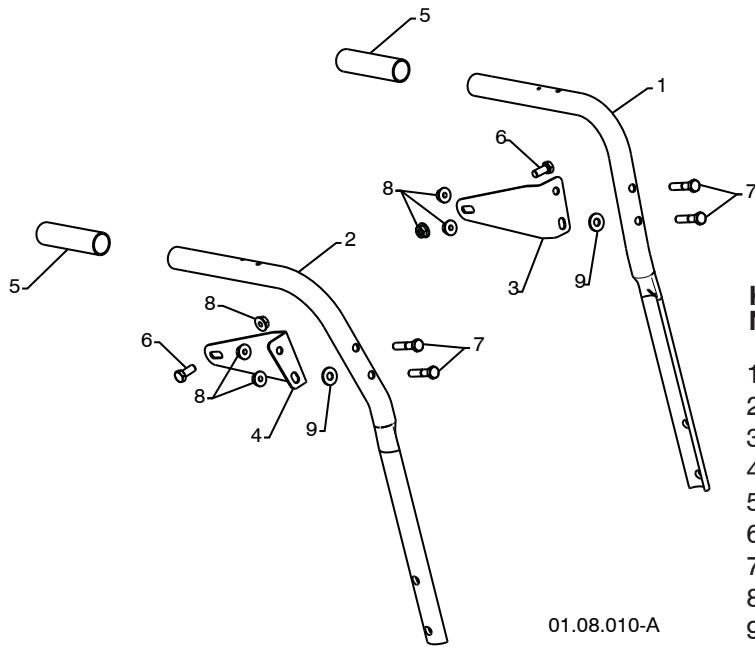

01.08.010-A

KEY NO.	PART NO.	DESCRIPTION
1	532 42 17-08	PLOW HANDLE LH
2	532 42 17-09	PLOW HANDLE RH
3	532 42 91-48	PANEL BRACKET LH
4	532 42 91-49	PANEL BRACKET RH
5	532 19 95-13	HANDLE GRIP
6	874 78 05-12	SCREW 5/16-18 X .750
7	874 78 05-24	SCREW 5/16-18 X 1.50
8	532 75 11-53	NUT 5/16-18
9	532 15 54-15	WASHER

NOTE: All component dimensions given in U.S. inches. 1 inch = 25.4 mm
IMPORTANT: Use only Original Equipment Manufacturer (O.E.M.) replacement parts.
 Failure to do so could be hazardous, damage your snow thrower and void your warranty.

REPAIR PARTS

HANDLES

SNOW THROWER - MODEL NO. 1830SB (96193005000), PRODUCT NO. 961 93 00-50

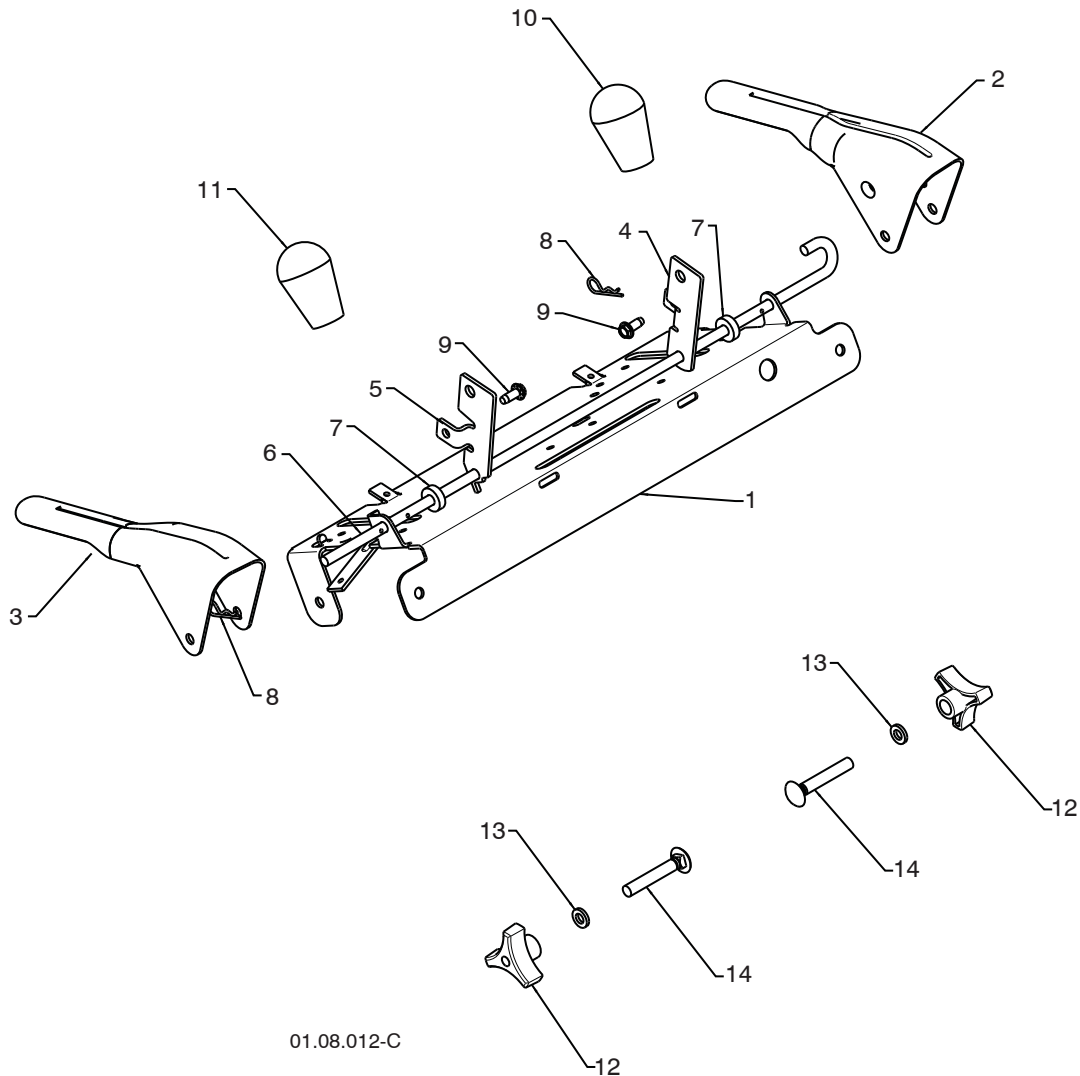

KEY NO.	PART NO.	DESCRIPTION
1	532 41 55-39	CONTROL PANEL
2	532 42 91-50	CONTROL LEVER LH
3	532 42 91-51	CONTROL LEVER RH
4	532 42 90-97	TRACTION ROD ARM
5	532 42 90-98	IMPELLER ROD ARM
6	532 41 26-77	INTERLOCK ROD
7	532 42 16-13	SPACER
8	532 16 96-75	RETAINER
9	817 06 04-10	SCREW 1/4-20 X .62
10	532 41 42-80	KNOB BLACK
11	532 41 42-81	KNOB RED
12	532 17 88-99	HANDLE KNOB
13	819 13 13-16	WASHER 3/8
14	872 12 06-18	CARRIAGE BOLT 3/8-16 X 2.25

NOTE: All component dimensions given in U.S. inches. 1 inch = 25.4 mm
IMPORTANT: Use only Original Equipment Manufacturer (O.E.M.) replacement parts. Failure to do so could be hazardous, damage your snow thrower and void your warranty.

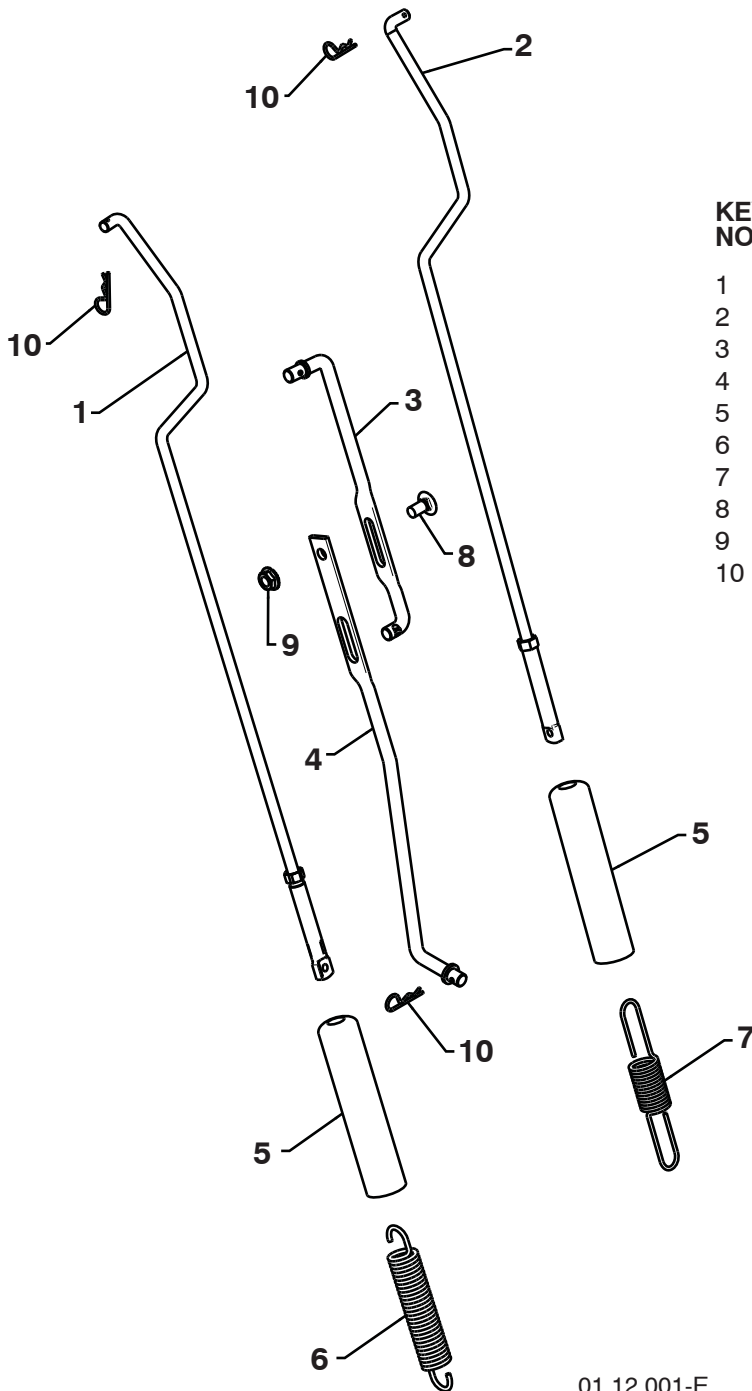

KEY NO.	PART NO.	DESCRIPTION
1	532 18 04-80	IMPELLER ROD ASSEMBLY
2	532 40 57-40	TRACTION ROD ASSEMBLY
3	532 18 04-45	SHIFTER ROD TOP
4	532 18 77-16	SHIFTER ROD BOTTOM
5	532 18 04-47	SPRING SLEEVE
6	532 17 86-69	IMPELLER SPRING
7	532 18 09-26	TRACTION SPRING
8	872 27 05-05	CARRIAGE BOLT 5/16-18 X .75
9	532 15 53-77	NUT 5/16-18
10	532 16 96-75	RETAINER

01.12.001-E

NOTE: All component dimensions given in U.S. inches. 1 inch = 25.4 mm
IMPORTANT: Use only Original Equipment Manufacturer (O.E.M.) replacement parts.
 Failure to do so could be hazardous, damage your snow thrower and void your warranty.

REPAIR PARTS

HANDLES

SNOW THROWER - MODEL NO. 1830SB (96193005000), PRODUCT NO. 961 93 00-50

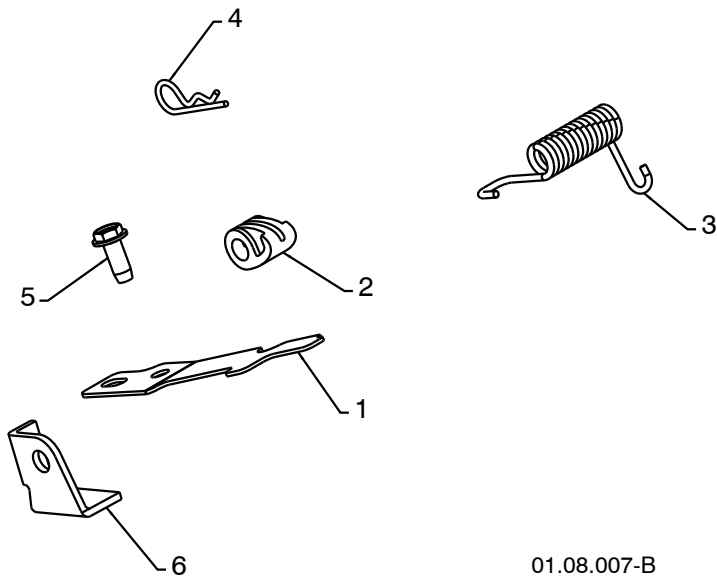

KEY NO.	PART NO.	DESCRIPTION
1	532 41 62-88	INTERLOCK SPRING
2	532 41 45-72	INTERLOCK CAM
3	532 17 88-31	TORSION SPRING
4	532 16 96-75	RETAINER
5	817 06 04-10	SCREW 1/4-20 X .625
6	532 42 18-14	INTERLOCK STOP

01.08.007-B

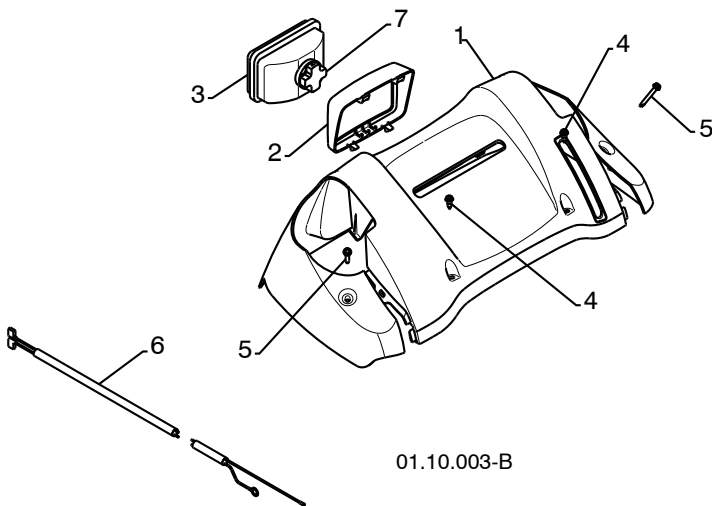

KEY NO.	PART NO.	DESCRIPTION
1	532 42 13-81	CONSOLE PANEL
2	532 42 14-48	HEADLIGHT BEZEL
3	532 18 09-27	FLOOD HEADLIGHT
4	532 18 44-71	SHOULDERSCREW 10-24 X .625
5	532 17 52-62	SCREW 10-24 X 1.25
6	532 17 87-70	WIRE HARNESS
7	532 18 37-84	BULB

01.10.003-B

NOTE: All component dimensions given in U.S. inches. 1 inch = 25.4 mm
IMPORTANT: Use only Original Equipment Manufacturer (O.E.M.) replacement parts. Failure to do so could be hazardous, damage your snow thrower and void your warranty.

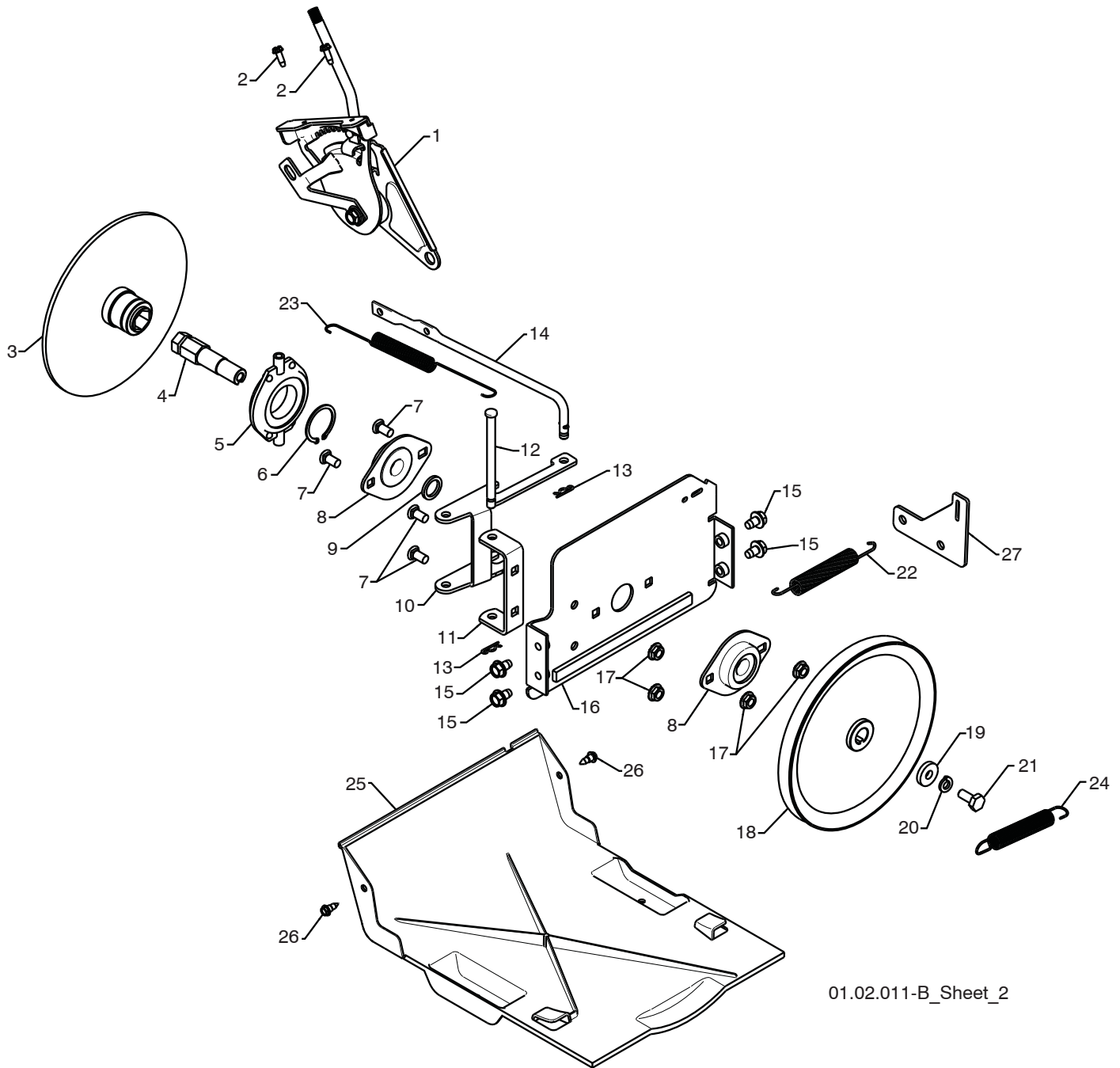

01.02.011-B_Sheet_2

NOTE: All component dimensions given in U.S. inches. 1 inch = 25.4 mm
IMPORTANT: Use only Original Equipment Manufacturer (O.E.M.) replacement parts.
 Failure to do so could be hazardous, damage your snow thrower and void your warranty.

SNOW THROWER - MODEL NO. **1830SB** (96193005000), PRODUCT NO. 961 93 00-50

KEY NO.	PART NO.	DESCRIPTION
1	532 19 88-75	SPEED SELECTOR HEAD ASSEMBLY
2	817 50 10-10	SCREW 10-24 X .625
3	532 19 77-63	DRIVE PLATE WELDMENT
4	532 19 77-64	HEX SHAFT
5	532 17 53-44	TRUNNION BEARING ASSEMBLY
6	812 00 00-12	RETAINER
7	872 27 05-05	CARRIAGE BOLT 5/16-18 X .625
8	532 18 89-09	FLANGE BEARING
9	532 18 25-04	SPACER
10	532 18 40-77	LEVER SHIFTER PLATE
11	532 18 40-76	SHIFTER SUPPORT BRACKET
12	532 17 86-95	PIN
13	532 08 51-79	RETAINER
14	532 40 33-00	CLUTCH ROD
15	817 49 05-08	BOLT 5/16-18 X .500
16	532 18 40-75	DRIVE MOUNT PLATE
17	532 15 53-77	NUT 5/16-18
18	532 19 10-80	TRACTION PULLEY
19	819 11 15-07	WASHER
20	810 04 05-00	LOCKWASHER 5/16
21	874 95 05-12	SCREW 5/16-18 X .750
22	532 41 45-57	TRACTION SPRING
23	532 17 90-95	RETURN SPRING
24	532 17 88-28	BRAKE SPRING
25	532 41 08-77	BOTTOM PAN
26	532 18 44-71	SCREW 10-24 X .625
27	532 41 66-82	TRACTION SPRING BRACKET

NOTE: All component dimensions given in U.S. inches. 1 inch = 25.4 mm

IMPORTANT: Use only Original Equipment Manufacturer (O.E.M.) replacement parts. Failure to do so could be hazardous, damage your snow thrower and void your warranty.

SNOW THROWER - MODEL NO. 1830SB (96193005000), PRODUCT NO. 961 93 00-50

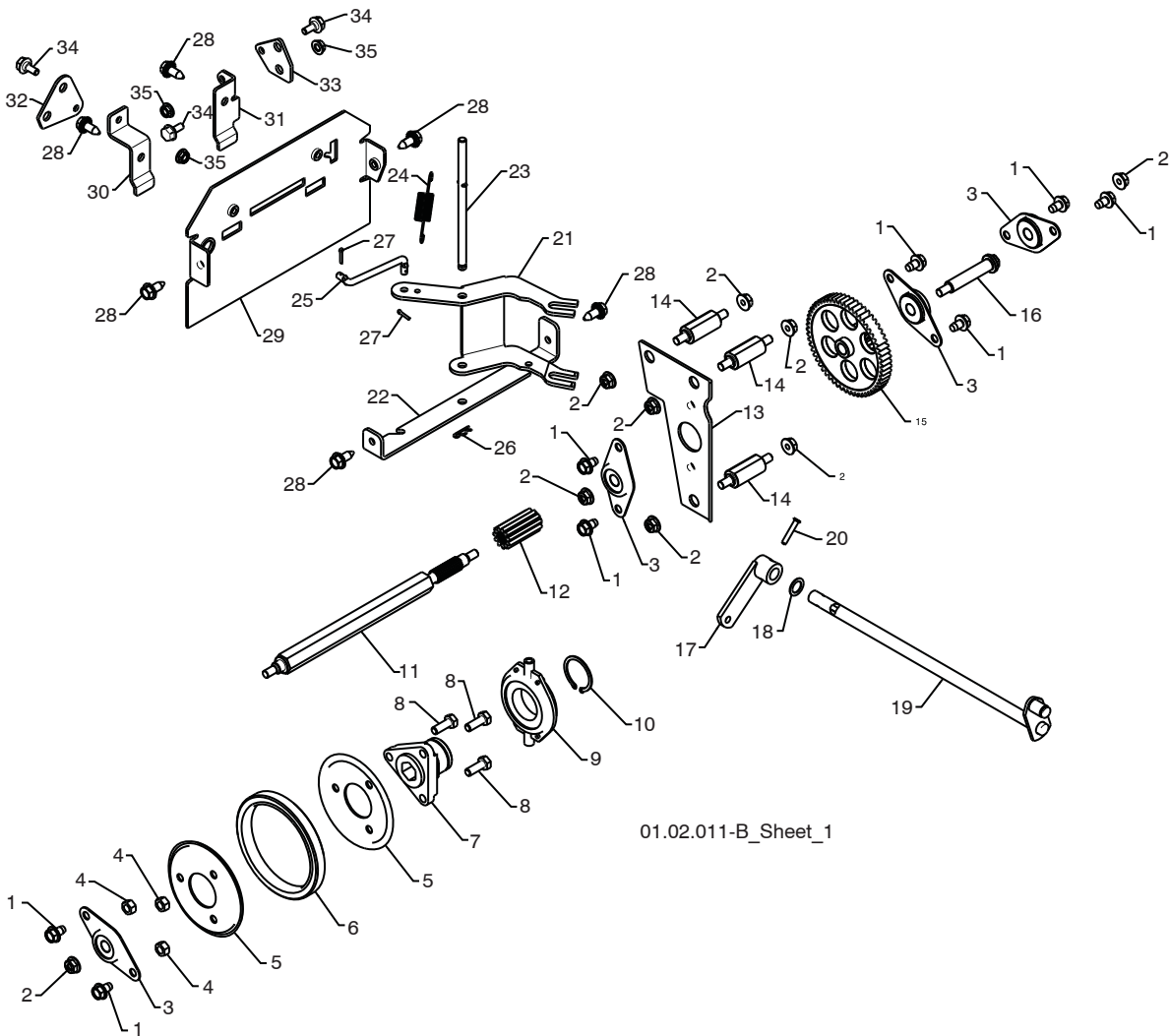

01.02.011-B_Sheet_1

KEY NO.	PART NO.	DESCRIPTION	KEY NO.	PART NO.	DESCRIPTION
1	817 49 05-08	BOLT 5/16-18 X .500	19	532 42 75-42	CONTROL SHAFT ASSEMBLY
2	532 75 11-53	NUT 5/16-18	20	532 19 85-80	CLEVIS PIN
3	532 18 00-17	FLANGE BEARING	21	532 18 40-80	SHIFTER LEVER
4	873 93 05-00	NUT 5/16-18	22	532 18 78-57	PIVOT BRACKET
5	532 19 95-09	RUBBER WHEEL PLATE	23	532 17 88-07	PIVOT PIN
6	532 17 98-31	RUBBER WHEEL RING	24	532 18 01-35	SPRING
7	532 17 86-13	RUBBER WHEEL HUB	25	532 18 71-01	SHIFTER LINK
8	874 76 05-14	BOLT 5/16-18 X .875	26	532 08 51-79	RETAINER
9	532 17 53-44	TRUNNION BEARING ASSEMBLY	27	532 70 02-79	CLIP
10	812 00 00-12	RETAINER	28	532 42 88-67	SCREW 5/16-18 x .750
11	532 18 00-66	HEX SHAFT	29	532 41 69-21	REAR PLATE
12	532 18 00-65	PINION GEAR	30	532 41 54-33	SHIFTER PLATE BRACKET
13	532 19 29-07	AUXILIARY PLATE	31	532 41 68-64	CLUTCH PLATE BRACKET
14	532 17 92-70	SPACER PLATE	32	532 41 54-50	SHIFTER PLATE
15	532 18 00-82	INTERMEDIATE GEAR	33	532 41 54-35	CLUTCH PLATE
16	532 18 01-34	AUXILIARY SHAFT	34	532 40 28-81	SHOULDER BOLT 3/8 x .25
17	532 40 54-85	CONTROL ARM	35	532 19 17-30	NUT 1/4-20
18	532 05 70-79	WASHER			

NOTE: All component dimensions given in U.S. inches. 1 inch = 25.4 mm

IMPORTANT: Use only Original Equipment Manufacturer (O.E.M.) replacement parts. Failure to do so could be hazardous, damage your snow thrower and void your warranty.

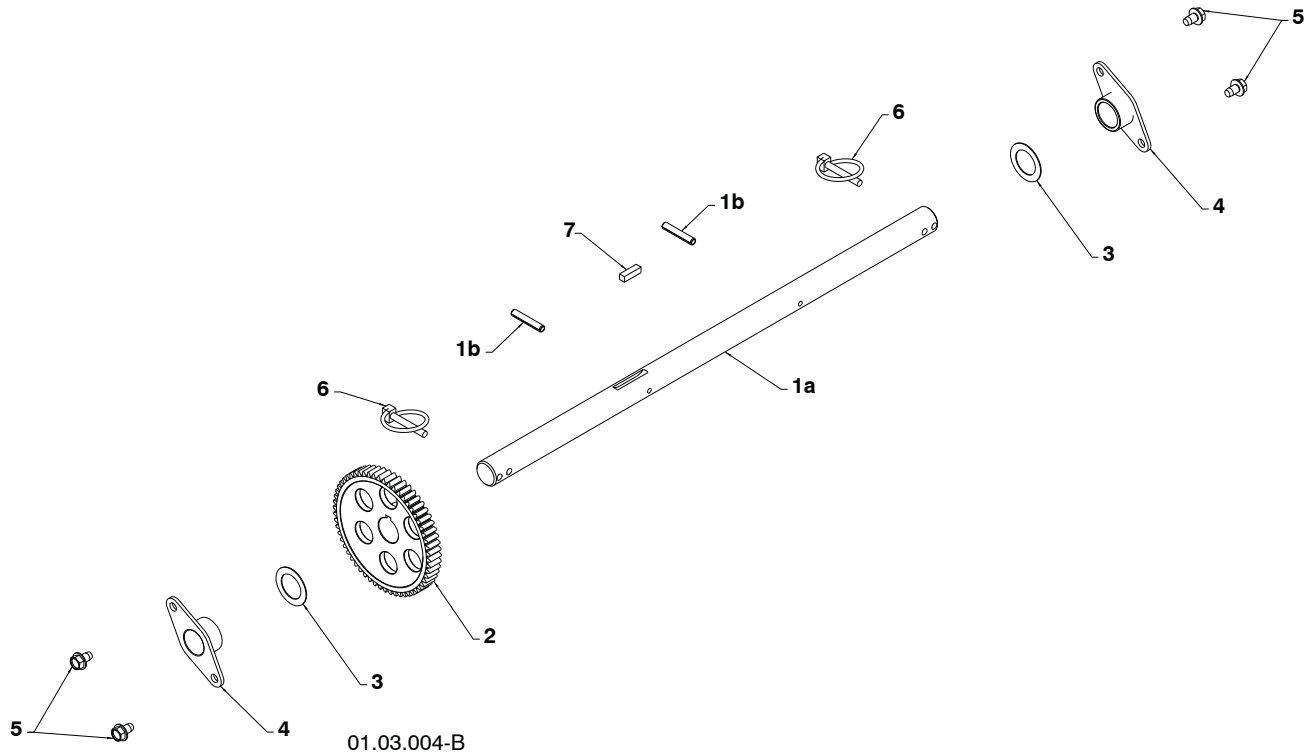

KEY NO.	PART NO.	DESCRIPTION
1	532 18 82-26	(assy of 1a,1b) AXLE ASSEMBLY
1a	532 17 93-52	AXLE SHAFT
1b	532 18 42-06	ROLL PIN 3/16
2	532 18 00-81	GEAR
3	532 17 46-97	THRUST WASHER
4	532 17 98-30	BEARING
5	817 49 05-08	BOLT 5/16-18 X .500
6	532 15 54-43	CLIK PIN
7	532 18 92-82	SQUARE KEY

NOTE: All component dimensions given in U.S. inches. 1 inch = 25.4 mm
IMPORTANT: Use only Original Equipment Manufacturer (O.E.M.) replacement parts. Failure to do so could be hazardous, damage your snow thrower and void your warranty.

REPAIR PARTS

CHASSIS / ENGINE / PULLEYS

SNOW THROWER - MODEL NO. 1830SB (96193005000), PRODUCT NO. 961 93 00-50

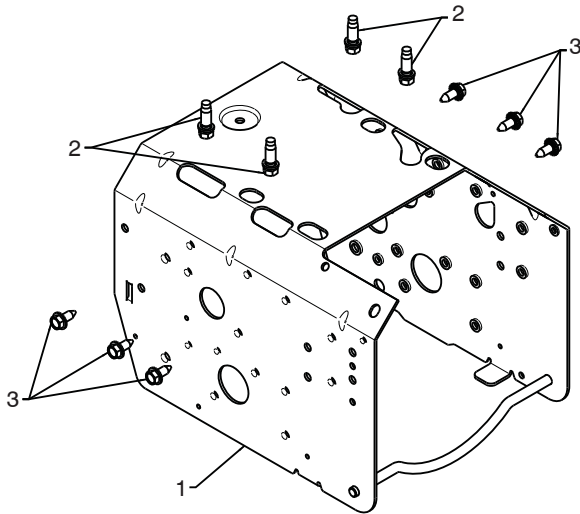

01.00.033-A

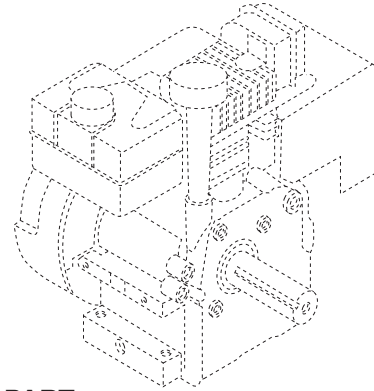

KEY NO.	PART NO.	DESCRIPTION
--	532 42 81-76	COMPLETE LCT ENGINE
1	532 42 92-03	FRAME
2	532 15 04-06	BOLT 3/8-16
3	532 42 88-67	SCREW 5/16-18 X .750

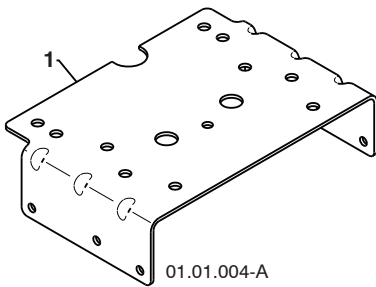

01.01.004-A

KEY NO.	PART NO.	DESCRIPTION
1	532 42 92-69	ENGINE MOUNTING PLATE

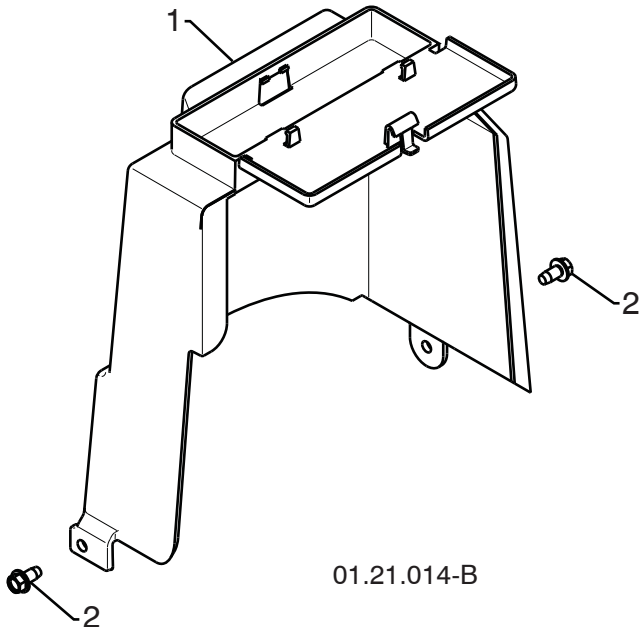

01.21.014-B

KEY NO.	PART NO.	DESCRIPTION
1	532 41 86-01	COVER ASSEMBLY
2	817 49 04-08	SCREW 1/4-20 X .50

NOTE: All component dimensions given in U.S. inches. 1 inch = 25.4 mm
IMPORTANT: Use only Original Equipment Manufacturer (O.E.M.) replacement parts.
 Failure to do so could be hazardous, damage your snow thrower and void your warranty.

REPAIR PARTS

CHASSIS / ENGINE / PULLEYS

SNOW THROWER - MODEL NO. 1830SB (96193005000), PRODUCT NO. 961 93 00-50

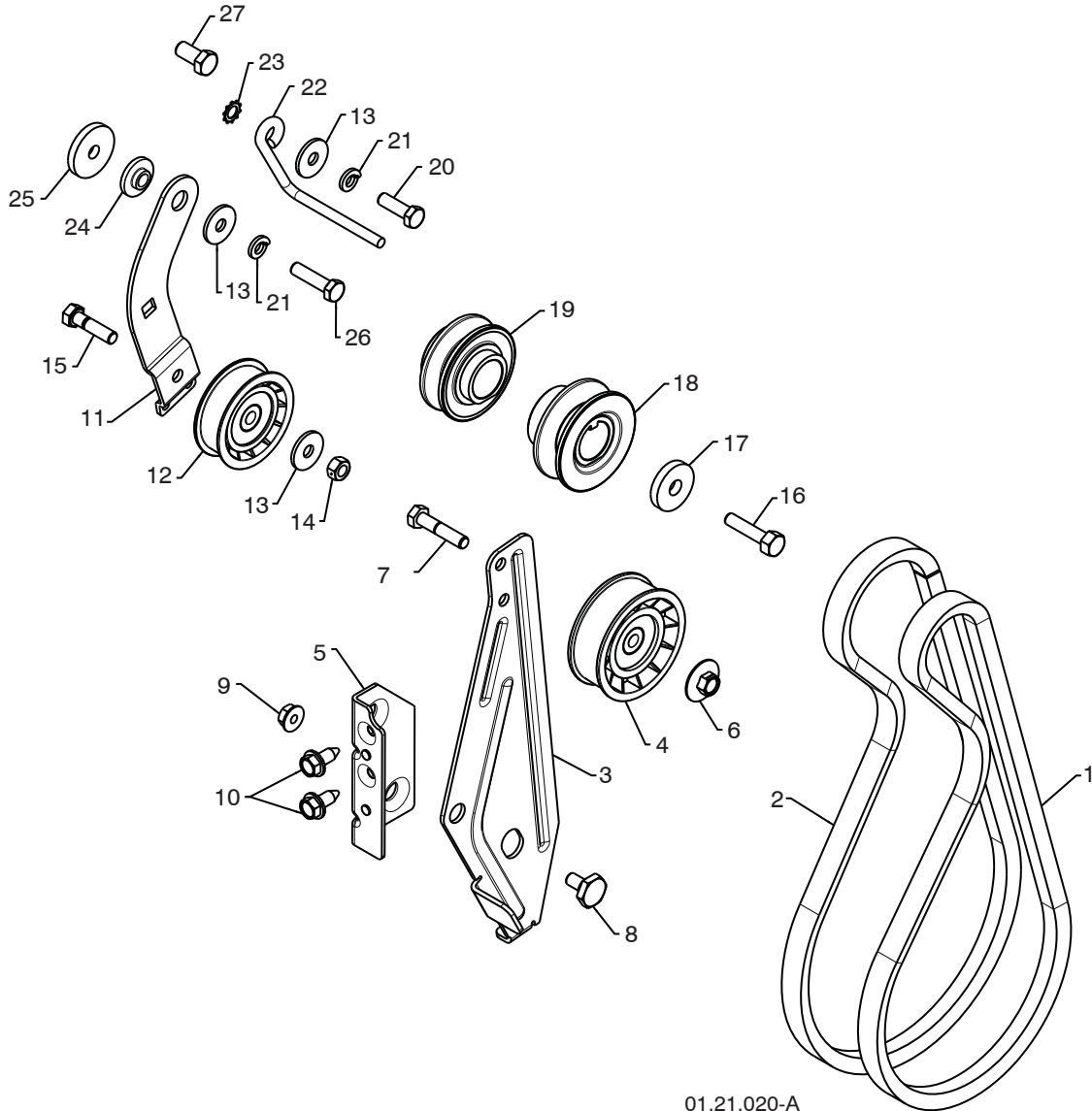

01.21.020-A

KEY NO.	PART NO.	DESCRIPTION	KEY NO.	PART NO.	DESCRIPTION
1	532 41 98-88	IMPELLER BELT	15	874 78 05-20	SCREW 5/16-18 X 1.25
2	532 42 73-04	TRACTION BELT	16	532 85 10-84	SCREW 3/8-24 X 1 .375
3	532 42 37-23	IDLER ARM BRACKET	17	819 13 20-05	WASHER
4	532 18 05-23	IDLER PULLEY	18	532 42 59-34	PULLEY ENG IMPELLER
5	532 42 39-90	IDLER BRACKET	19	532 42 59-33	PULLEY ENG TRACTION
6	532 42 65-89	NUT 5/16-18	20	874 61 05-16	SCREW 5/16-24 X 1.00
7	874 78 05-24	SCREW 5/16-18 X 1.50	21	810 04 05-00	LOCKWASHER 5/16
8	532 42 42-97	SHOULDER BOLT 5/16-18 X .50	22	532 15 54-52	BELT GUIDE
9	532 75 11-53	NUT 5/16-18 LOCK	23	811 05 05-00	LOCKWASHER 5/16
10	532 42 88-67	SCREW 5/16-18 X .625	24	532 17 53-31	IDLER BUSHING
11	532 42 75-76	TRACTION IDLER BRACKET	25	819 11 22-06	WASHER
12	532 18 05-22	TRACTION PULLEY	26	874 61 05-20	SCREW 5/16-24 X 1.25
13	532 05 92-89	WASHER	27	874 76 06-08	SCREW 3/8-16 X .750
14	873 80 05-00	NUT 5/16-18			

NOTE: All component dimensions given in U.S. inches. 1 inch = 25.4 mm
IMPORTANT: Use only Original Equipment Manufacturer (O.E.M.) replacement parts.
 Failure to do so could be hazardous, damage your snow thrower and void your warranty.

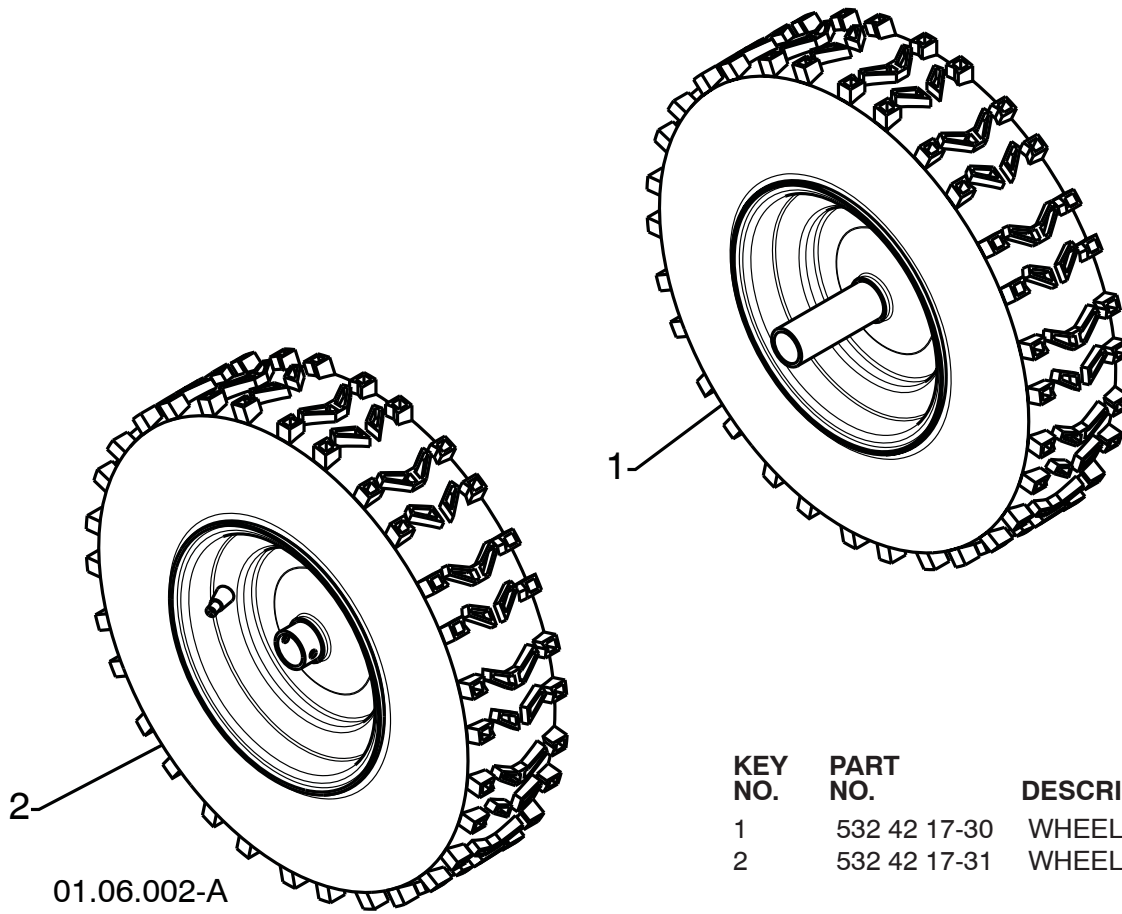

KEY NO.	PART NO.	DESCRIPTION
1	532 42 17-30	WHEEL ASSEMBLY LH
2	532 42 17-31	WHEEL ASSEMBLY RH

NOTE: All component dimensions given in U.S. inches. 1 inch = 25.4 mm
IMPORTANT: Use only Original Equipment Manufacturer (O.E.M.) replacement parts.
 Failure to do so could be hazardous, damage your snow thrower and void your warranty.

REPAIR PARTS

BAG OF PARTS

SNOW THROWER - MODEL NO. 1830SB (96193005000), PRODUCT NO. 961 93 00-50

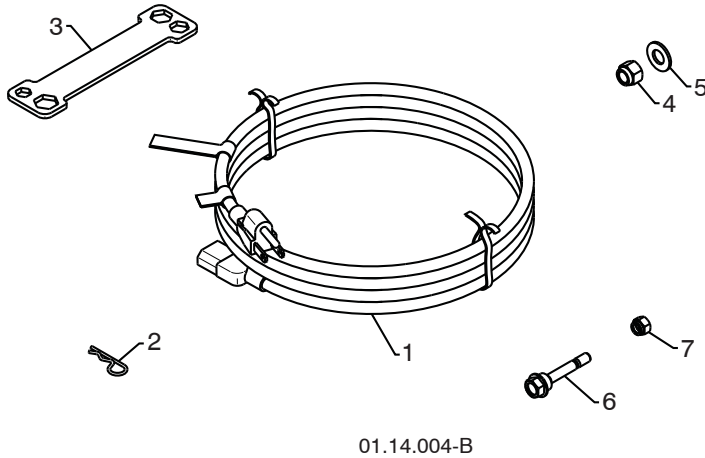

KEY NO.	PART NO.	DESCRIPTION
1	532 19 85-63	POWER CORD
2	532 16 96-75	RETAINER PIN
3	532 42 91-12	WRENCH
4	873 80 06-00	LOCKNUT 3/8-16
5	819 13 13-16	WASHER 3/8
6	532 19 20-90	SHEAR BOLT 1/4-20 X 1-3/4
7	873 80 04-00	LOCKNUT 1/4-20

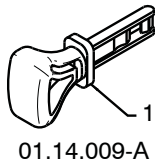

KEY NO.	PART NO.	DESCRIPTION
1	532 42 26-63	SAFETY IGNITION KEY

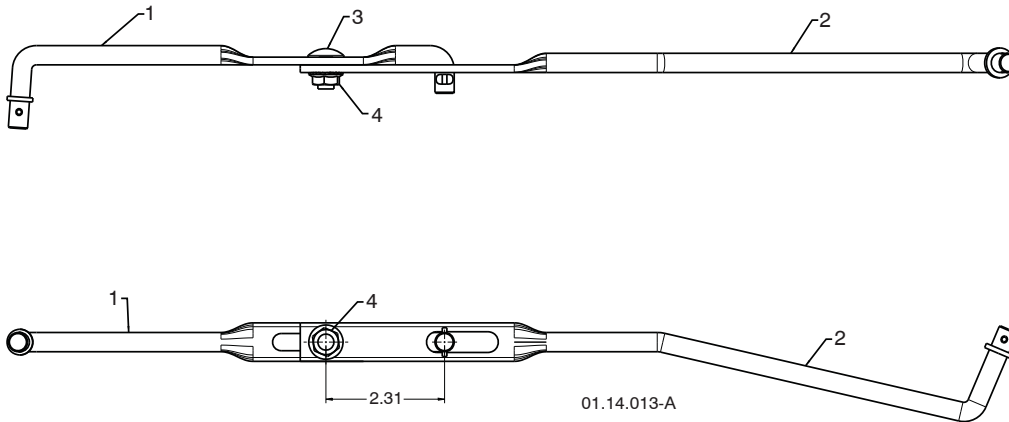

KEY NO.	PART NO.	DESCRIPTION
1	532 18 04-45	SHIFTER ROD TOP
2	532 18 77-16	SHIFTER ROD BOTTOM
3	872 27 05-05	CARRIAGE BOLT 5/16-18 X .75
4	532 15 53-77	NUT 5/16-18

NOTE: All component dimensions given in U.S. inches. 1 inch = 25.4 mm
IMPORTANT: Use only Original Equipment Manufacturer (O.E.M.) replacement parts.
 Failure to do so could be hazardous, damage your snow thrower and void your warranty.

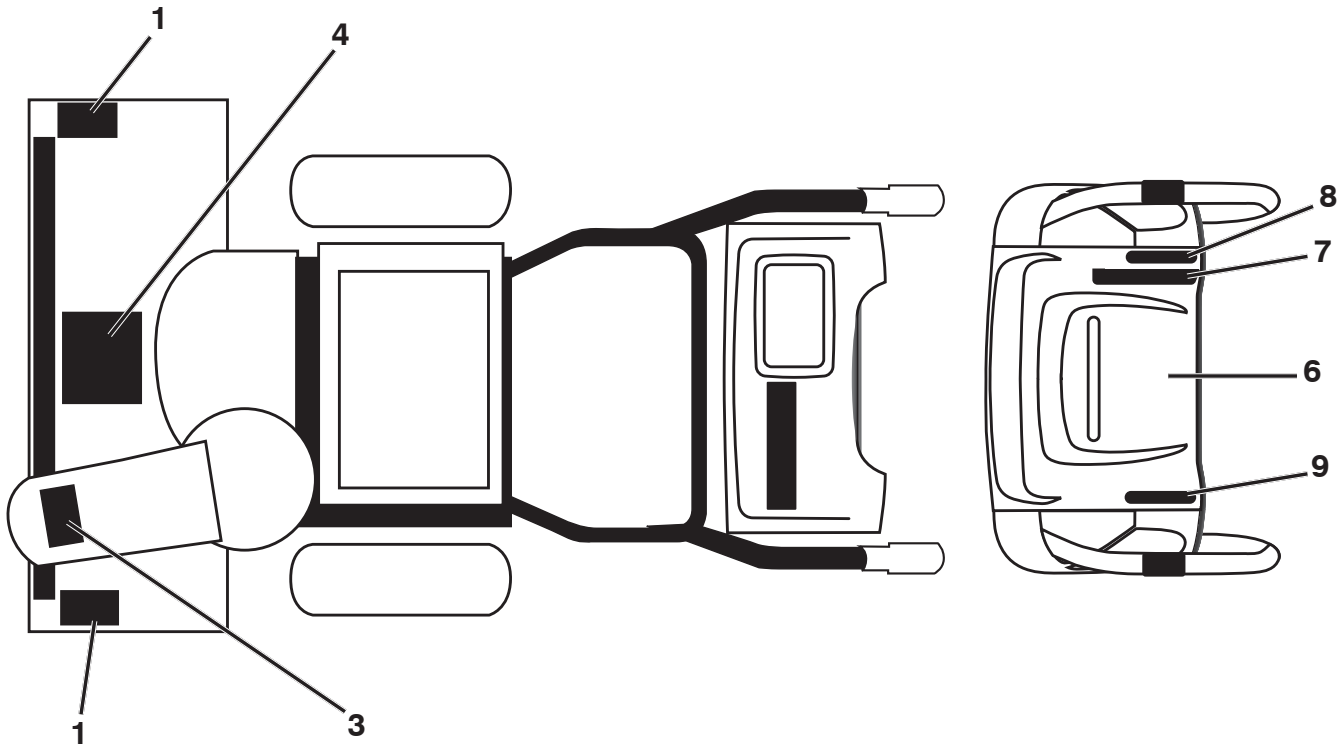

KEY NO.	PART NO.	DESCRIPTION
1	532 18 10-37	DECAL, DANGER
3	532 18 10-35	DECAL, DANGER, DEFLECTOR
4	532 18 10-42	DECAL, DANGER
6	532 18 10-33	DECAL, INSTRUCTION, E/F
7	532 41 54-75	DECAL, SPEED CONTROL
8	532 41 53-90	DECAL, AUGER, LEVER
9	532 41 53-91	DECAL, TRACT/CLUTCH. LEV. LH

NOTE: All component dimensions given in U.S. inches. 1 inch = 25.4 mm
IMPORTANT: Use only Original Equipment Manufacturer (O.E.M.) replacement parts.
 Failure to do so could be hazardous, damage your snow thrower and void your warranty.