

Router - F 012 183 002 - 1830

Item	Part Number	Description	Illustration	Price	Quantity	Price Group
1	1 619 X04 235	Motor Housing	1	-,-	1	24
2	1 619 P01 569	Field 120V	1	-,-	1	31
3	1 619 P01 566	Armature 120V	1	-,-	1	33
4	1 619 X04 229	Switch Unit	1	-,-	1	19
5	1 619 X04 241	Power supply cord	1	-,-	1	22
8	1 619 X04 691	Nameplate	1	-,-	1	-
9	1 619 X04 661	Manufacturer's nameplate	1	-,-	1	13
13	2 610 017 875	Ball Bearing	1	-,-	1	20
14	1 619 P01 511	Ball Bearing	1	-,-	1	19
22	1 619 X04 666	Electronic Module	1	-,-	1	28
23	1 619 X05 187	Electronic Module	1	-,-	1	15
24	2 610 916 621	Tolerance Ring	1	-,-	1	12
25	1 619 X00 658	Screw	1	-,-	2	11
26	1 619 X04 240	Insulator	1	-,-	1	11
27	1 619 X02 496	Fastener	1	-,-	3	11
28	1 619 X04 236	Lock Plate	1	-,-	1	13
29	2 610 932 299	Torsion Spring	1	-,-	1	11
30	2 610 315 386	Screw ST3,9x19	1	-,-	8	11
31	1 619 X04 234	Housing Cover	1	-,-	1	17
32	1 619 X04 230	Trigger	1	-,-	1	11
33	1 619 X04 231	Switch Cover	1	-,-	1	11
34	1 619 X04 198	Cover	1	-,-	1	11
35	1 619 X04 237	Bearing Housing	1	-,-	1	16
36	1 619 X04 232	Screw	1	-,-	1	11
37	1 619 X02 811	Collet 1/2"	1	-,-	1	24
38	2 610 990 022	Screw	1	-,-	4	11
39	1 619 X05 276	Plain Washer	1	-,-	2	11
102	1 619 X05 725	Knob	2	-,-	1	12
104	1 619 X04 253	Screw	2	-,-	2	11
105	1 619 X04 252	Retaining snap ring	2	-,-	1	11
106	1 619 X01 014	Spring Washer	2	-,-	1	10
107	1 619 X04 259	Washer	2	-,-	2	11
108	1 619 X04 249	Shaft	2	-,-	1	14

Item	Part Number	Description	Illustration	Price	Quantity	Price Group
109	1 619 X04 710	Adjusting Part	2	-,-	1	14
110	1 619 X04 711	Cover	2	-,-	1	11
111	1 619 X04 271	Cover	2	-,-	1	11
113	1 619 X04 197	Screw	2	-,-	2	11
114	1 619 X04 199	Handle	2	-,-	2	16
116	1 619 X04 250	Cover	2	-,-	1	11
117	1 619 X04 718	Compression Spring	2	-,-	1	11
118	1 619 X05 118	Lock Bolt	2	-,-	1	15
119	1 619 X04 251	Locking Lever	2	-,-	1	12
120	1 619 X04 721	Washer	2	-,-	1	11
122	1 619 X04 265	Clamping Lever	2	-,-	1	16
123	1 619 X04 266	Straight Pin	2	-,-	1	12
124	1 619 X04 268	Bolt	2	-,-	1	11
126	1 619 X04 269	Hex Nut	2	-,-	1	11
127	1 619 X04 262	Rod	2	-,-	1	14
128	1 619 X04 263	Indicator	2	-,-	1	11
129	1 619 X04 264	Knob	2	-,-	1	12
130	1 619 X04 261	Label	2	-,-	1	11
202	1 619 X04 256	Compression Spring	2	-,-	1	12
203	2 610 921 832	Bellows	2	-,-	2	14
204	2 916 650 003	Spring retaining ring DIN 471-12x1-FSt	2	-,-	1	10
206	2 610 916 624	Compression Spring	2	-,-	1	11
207	2 600 590 006	Ratchet Cap	2	-,-	1	11
208	1 619 X04 723	Washer	2	-,-	1	11
209	1 619 X04 724	Screw	2	-,-	1	11
210	1 619 X04 274	Stop	2	-,-	1	16
211	1 619 X04 273	Chip Deflector	2	-,-	1	12
213	1 619 X05 012	Screw	2	-,-	5	11
214	1 619 X04 278	Base Plate	2	-,-	1	16
216	1 619 X05 276	Plain Washer	2	-,-	2	11
220	1 619 X05 375	Warning Label	2	-,-	1	13
322	1 619 X04 191	Base	3	-,-	1	-
323	1 619 X04 190	Clamping Lever	3	-,-	1	-
324	1 619 X04 199	Handle	3	-,-	2	16
325	1 619 X04 194	Chip Deflector	3	-,-	1	-
326	1 619 X04 192	Cover Plate	3	-,-	1	-
327	1 619 X05 724	Knob	3	-,-	1	-
329	1 619 X04 179	Support bracket	3	-,-	1	-
330	1 619 X04 197	Screw	3	-,-	2	11
331	1 619 X04 253	Screw	3	-,-	2	11
332	1 619 X04 184	Retaining ring	3	-,-	1	-
333	1 619 X05 012	Screw	3	-,-	5	11
334	1 619 X05 276	Plain Washer	3	-,-	2	11
335	1 619 X04 187	Bolt	3	-,-	1	-
336	1 619 X04 269	Hex Nut	3	-,-	1	11
337	1 619 X04 178	Shaft	3	-,-	1	-
338	1 619 X04 180	Worm	3	-,-	1	-
339	1 619 X04 266	Straight Pin	3	-,-	1	12
340	1 619 X04 181	Spring	3	-,-	1	-
341	1 619 X04 183	Cover	3	-,-	1	-
342	1 619 X04 188	Washer	3	-,-	1	-
651	1 619 X01 769	Adjusting Wrench	1	-,-	1	16
652	1 619 X03 843	Adapter	1	-,-	1	17

Item	Part Number	Description	Illustration	Price	Quantity	Price Group
810	1 619 X05 563	Carbon-Brush Set	1	-,-	1	18
811	1 619 X05 564	Service kit	2	-,-	1	35
812	1 619 X05 565	Service kit	2	-,-	1	31

Illustration - Type E

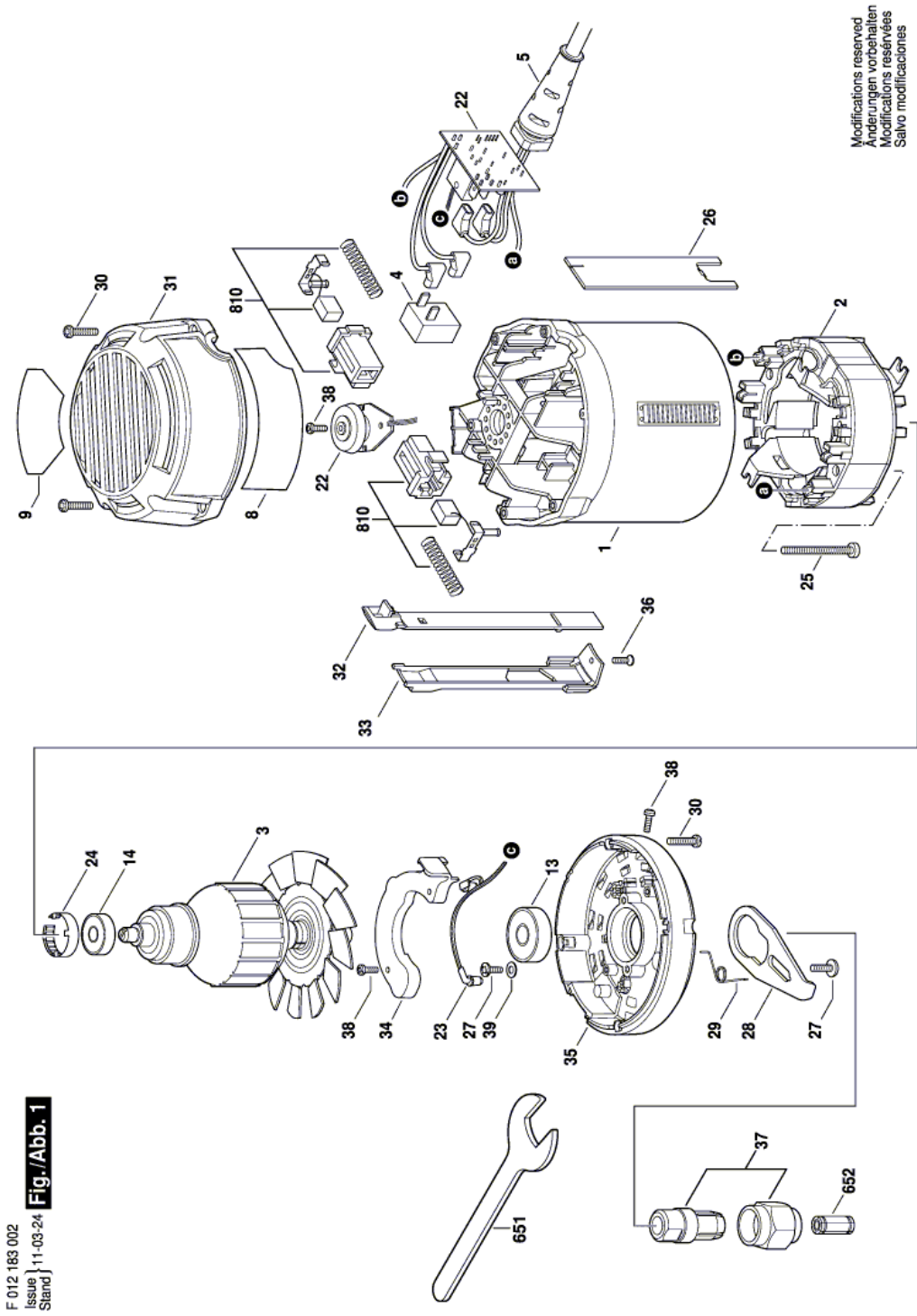

Modifications reserved
Änderungen vorbehalten
Modificacions reservées
Salvo modificaciones

Illustration - Type E

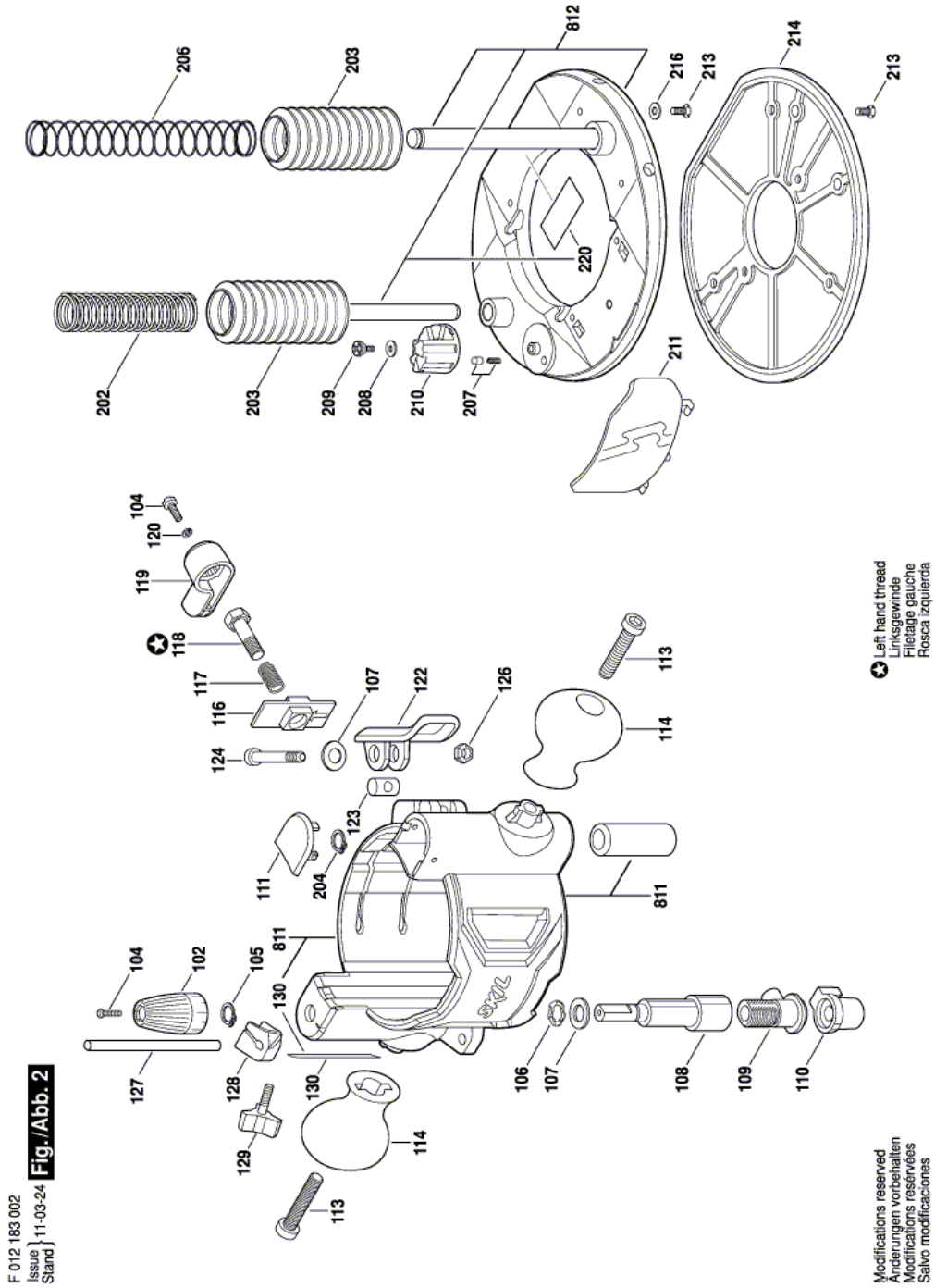

F 012 183 002
 (Issue) 11-03-24
 Stand } **Fig./Abb. 2**

Illustration - Type E

F 012 183 002
Issue 11-03-24
Stand

Fig./Abb. 3

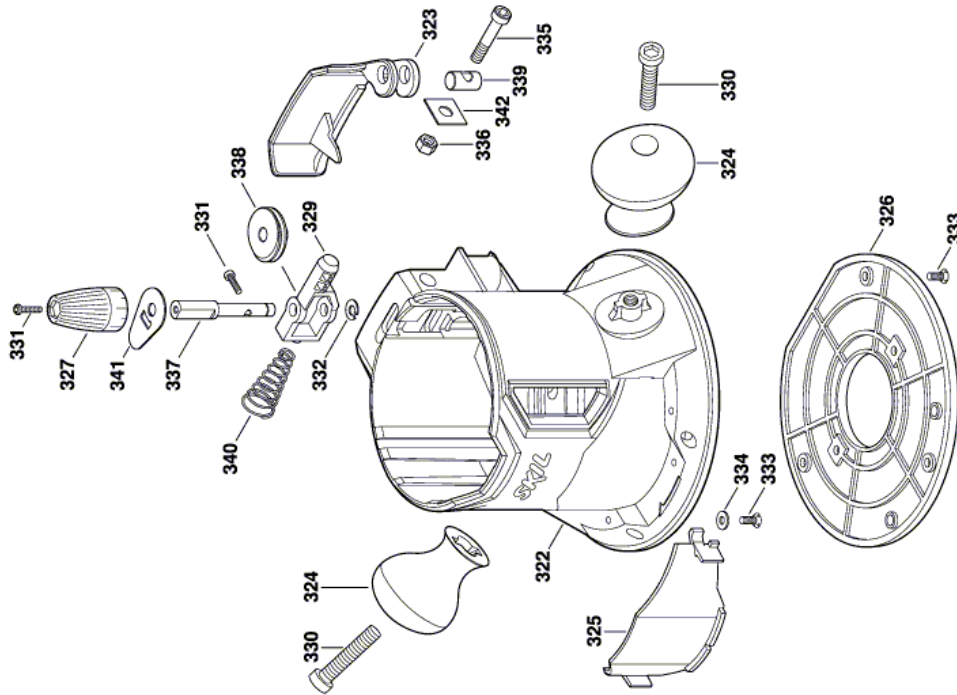

Modifications reserved
Änderungen vorbehalten
Modificacions reservées
Salvo modificaciones

Information subject to change without further notice.