

180R62 Heavy-Duty Generator UT-03625 - Generator & Control Box

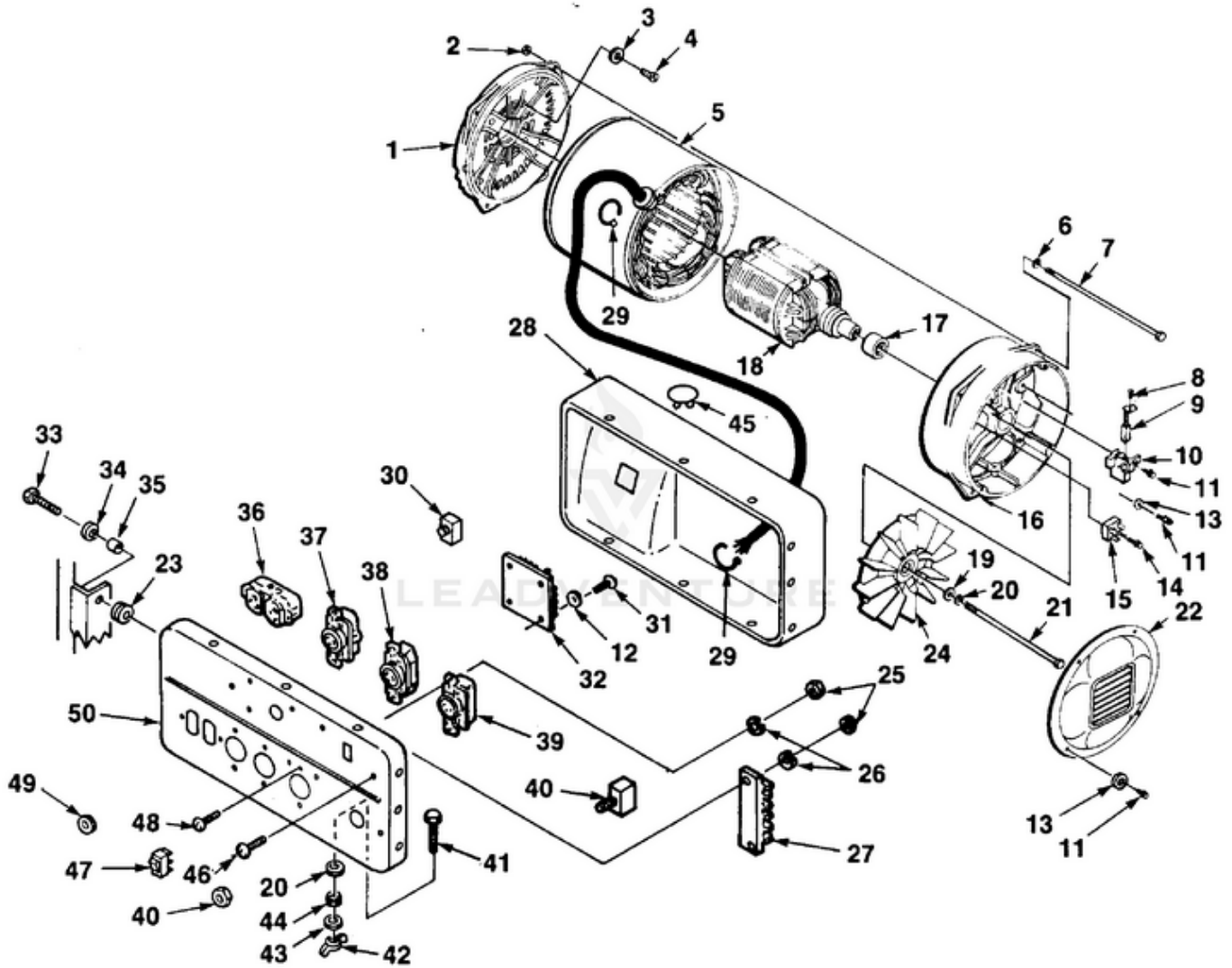

Rendered by LeadVenture, Inc.

Ref #	Part #	Description	Qty	Context Note
1	5375225	END BELL	1	
2	81053	NUT-Hex 1/4-20	4	
3	83117	WASHER-Lock	4	
4	80187	SCREW-Hex hd 3/8-16 x 7/8	4	
5	A49331S	STATOR SHELL	1	
6	83070	WASHER-Lock Int. 1/4	4	
7	49171	BOLT-Stator	4	
8	80260	SCREW Mach. pan. hd. 8-32 x 3/8	2	
9	53762	BRUSH	2	
10	53760	BRUSH HOLDER	1	
11	82474	SCREW	7	
12	84025	WASHER #8	4	
13	83022	WASHER #8	9	
14	82205	SCREW-Hex tap. 8-32 x 3/4	1	
15	53818	RECTIFIER	1	
16	537592	BRUSH HEAD	1	
17	53819	BEARING	1	
18	A49094S	ROTOR	1	
19	84058	WASHER-Flat 5/16	1	
20	83002	WASHER-Lock 5/16	2	
21	49172	BOLT-Rotor	1	
22	513941	BRUSH HEAD COVER	1	
23	49351	GROMMET	4	
24	A53769	FAN	1	
25	81009	NUT-Hex 8-32	10	
26	83060	WASHER-Lock #8	10	
27	42366	BLOCK-Terminal	1	
28	A49271	PANEL COVER	1	
29	46840	CABLE-Tie	4	
30	49362	SWITCH (DPDT)	1	
31	80560	SCREW-Pan hd. #8-32 x 1/2	4	
32	A48999A	VOLTAGE REGULATOR	1	
33	82322	SCREW-Pan Hd 1/4-20 x 3/4	4	
34	84006	WASHER-Flat	4	
35	49350	SLEEVE	4	
36	50991	RECEPTACLE	1	
37	48978	RECEPTACLE	1	
38	42601	RECEPTACLE	1	
39	46508	RECEPTACLE	1	
40	48952	CIRCUIT BREAKER	1	
41	80086	SCREW-Hex hd. 5/16-18 x 1/8	1	
42	81015	WING NUT- 5/16-18	1	
43	83081	WASHER-Lock 5/16	4	

<b>Ref #</b>	<b>Part #</b>	<b>Description</b>	<b>Qty</b>	<b>Context</b>	<b>Note</b>
44	81018	NUT-Hex 5/16-18	1		
45	49368	CLAMP-Cable	1		
46	80582	SCREW-Pan Hd 8-32 x 5/8	2		
47	49299	SWITCH-Rocker	1		
48	80577	SCREW- 8-32	19		
49	47165	RING-Locking	1		
50	A49269	CONTROL PANEL	1		
	A49305	DECAL KIT	1		

180R62 Heavy-Duty Generator UT-03625 - Tank, Muffler & Frame

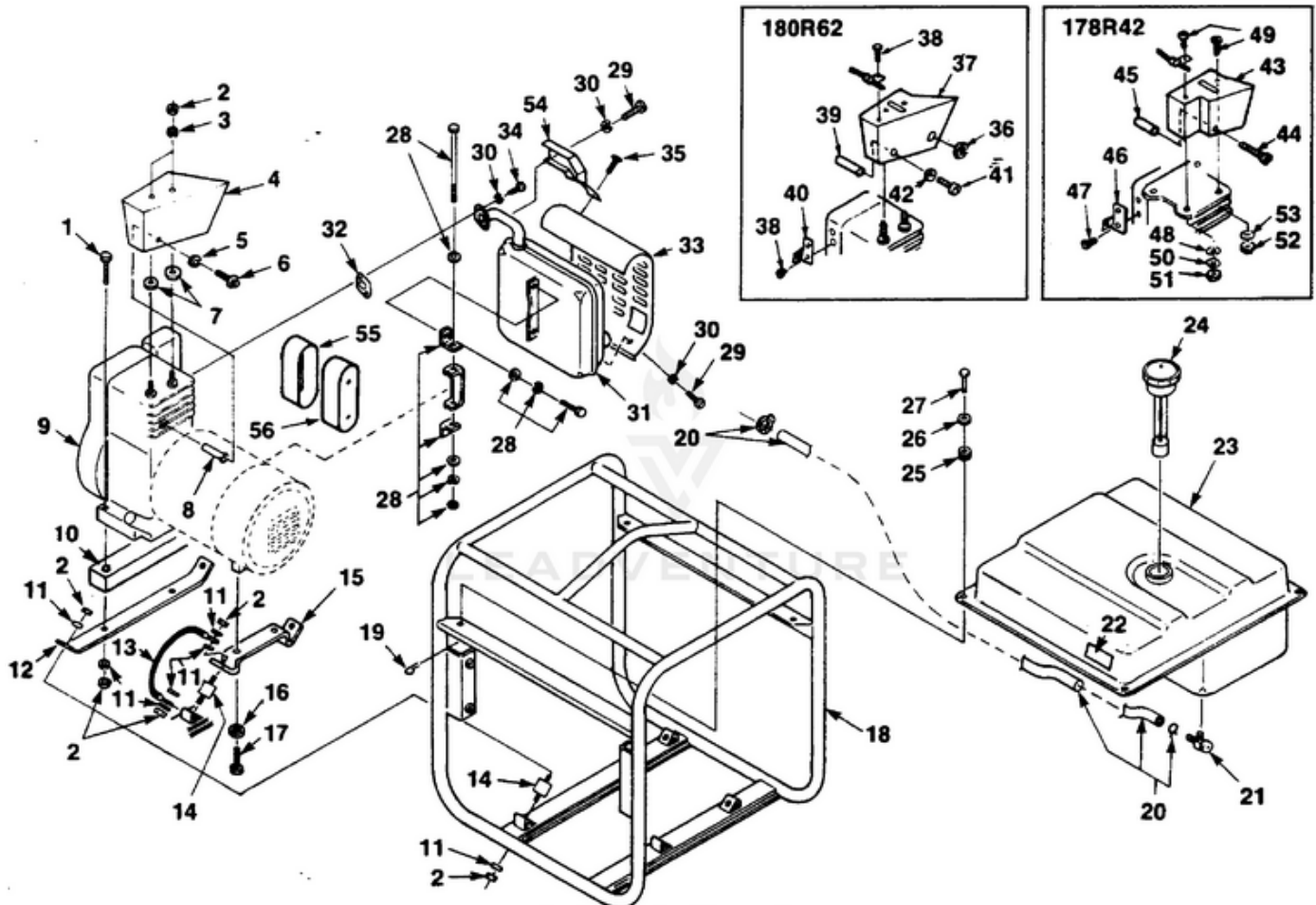

Rendered by LeadVenture, Inc.

Ref #	Part #	Description	Qty	Context Note
1	80288	SCREW Cap hex hd 5/16-18 x 1 3/4	2	
2	81162	NUT-Hex 5/16-18	8	
5	84110	WASHER-Flat #10	1	
6	46044	SCREW Mach Rd. Hd. 10-24 x 1 1/2	1	
7	84032	WASHER-Flat	2	
9	A49344S	ENGINE	1	
11	83081	WASHER-Int. Lock 5/16	10	
12	49265	SUPPORT-Engine	1	
13	A49399	GROUND STRAP	1	
14	49367	VIBRATION ISOLATOR	4	
15	48944	SUPPORT-Generator	1	
16	83033	WASHER-Lock Int.	4	
17	82206	SCREW- Thread Forming	2	
18	A493471	ROLL CAGE	1	
19	49412	PIN-Cotter	4	
20	A49306	FUEL LINE ASSEMBLY	1	Cut fuel line to the desired length
21	49005	FUEL VALVE	1	
22	49430	DECAL-I.D.	1	
23	489311	FUEL TANK	1	
24	49179	FUEL CAP	1	
25	49351	GROMMET-Isolator	8	
26	84006	WASHER-Flat	8	
27	49329	PIN-Clevis	4	
36	49122	GROMMET	1	
37	493161	DEFLECTOR-Air	1	
38	82279	SCREW Tap pan hd. #8-18 x 3/8	3	
39	49392	SPACER	1	
40	49369	BRACKET-Lite	1	
41	88127	SCREW-Hex 6mm x 40mm	1	
42	83061	WASHER- 1/4"	1	

# 180R62 Heavy-Duty Generator UT-03625 - Wiring Diagram

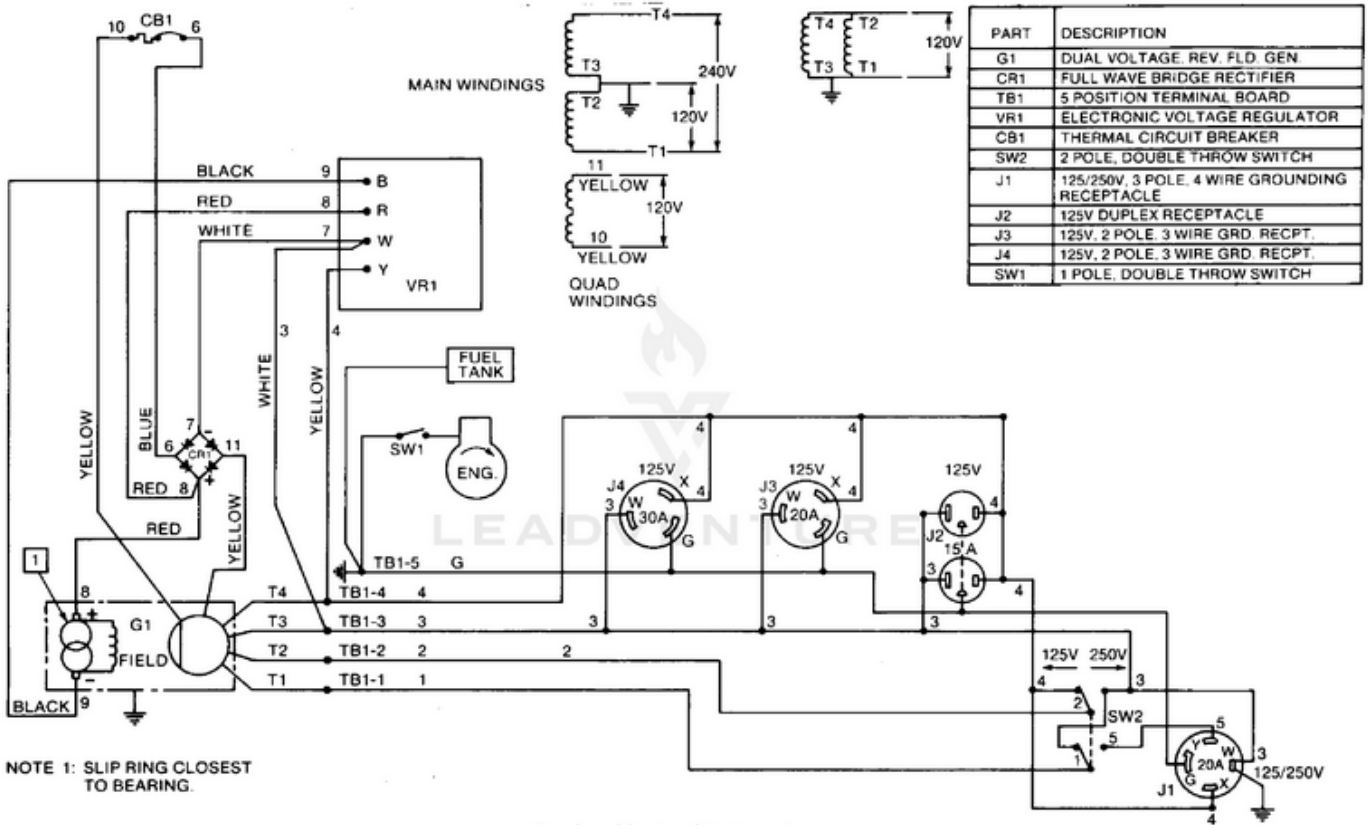

Rendered by LeadVenture, Inc.