

POWERMATIC

WMH TOOL GROUP

OWNER'S MANUAL PDS-12CS 12" Disc Sander



POWERMATIC
WMH Tool Group
www.powermatic.com

427 Sanford Rd.
LaVergne, TN 37086
e-mail powermatic@wmhtoolgroup.com

Phone: 253-351-6000
Fax: 1-800-274-6840
M-1791201K 06/02

Base Assembly Breakdown

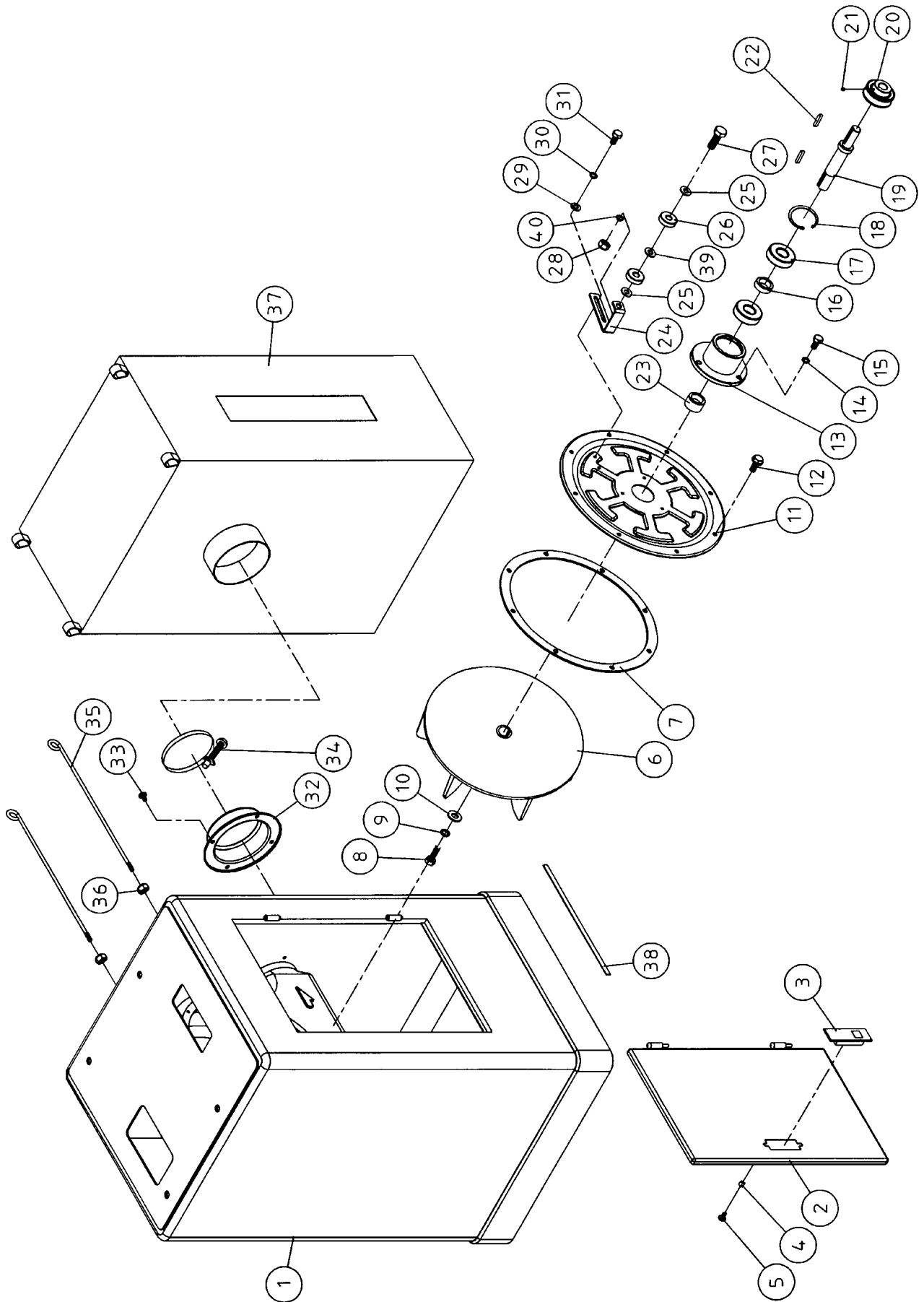

**Parts List for the PDS-12CS
Base Assembly**

Index No.	Part No.	Description	Size	Qty
1	612083	Closed Stand		1
2	612097	Door w/Latch Assembly		1
3	150503	Latch Assembly		1
4	150503-1	Spacer		2
5	SP040100	Pan Head Bolt	M4 x 5	2
6	331003	Impeller	10"	1
7	410030	Gasket		1
8	SH080402	Hex Head Bolt	M8 x 20 (LH)	1
9	TS-1551061	Lock Washer	M8	1
10	TS-1550061	Flat Washer	M8 x 30	1
11	612088	Cover		1
12	SG069300	Hex Flange Bolt	M6 x 12	8
13	612089	Bearing Housing		1
14	TS-1551041	Lock Washer	M6	3
15	TS-1482031	Cap Screw	M6 x 16	3
16	612112	Bushing		1
17	BB-6204LLU	Ball Bearing	6204LLU	2
18	RR470000	Retaining Ring	R47	1
19	612090	Shaft		1
20	612091	Pulley		1
21	TS1523031	Set Screw	M6 x 8	2
22	KD050530	Key	5 x 5 x 30	2
23	612121	Bushing		1
24	612094	Idle Wheel Bracket		1
25	TS1550071	Flat Washer	M10 x 20	2
26	BB-6200ZZ	Ball Bearing	6200ZZ	2
27	TS-149105	Hex Head Bolt	M10 x 35	1
28	TS-1540072	Nut	M10	1
29	TS-1550041	Flat Washer	M6 x 13	2
30	TS-1551041	Lock Washer	M6	2
31	TS-1482031	Cap Screw	M6 x 16	2
32	412007	Inlet Port	4"	1
33	SF069300	Pan Head Flange Bolt	M6 x 12	4
34	423968	Ring Clamp	4"	1
35	612095	Hanger		2
36	TS-1540041	Hex Nut	M6	2
37	612085	Collector Bag		1
38	150527	Sponge		2
39	620015	Washer	M10 x 20	1
40	TS-1551071	Lock Washer	M10	1

Sander Assembly Breakdown

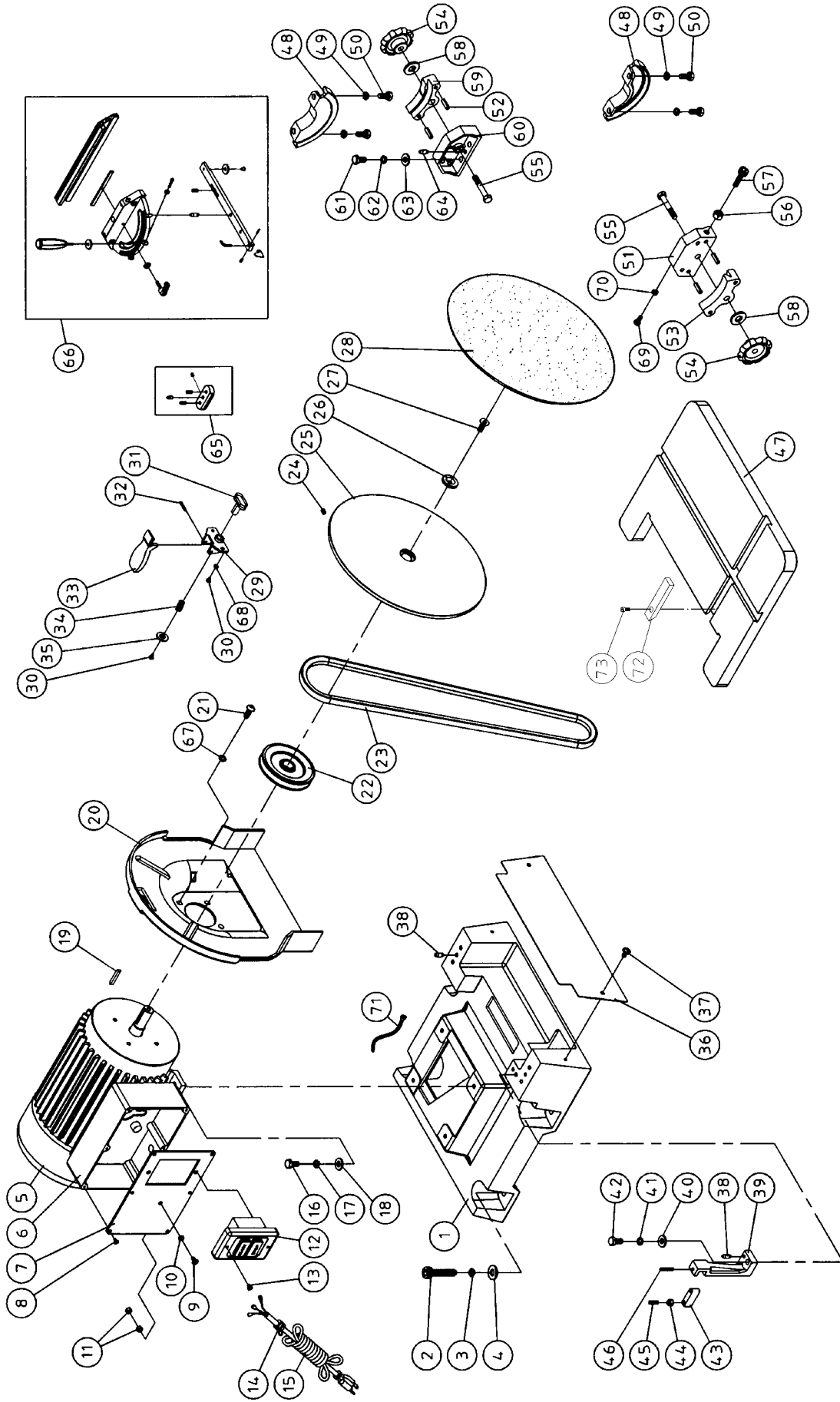

**Parts List for PDS-12CS
Sander Assembly**

Index No.	Part No.	Description	Size	Qty
1	612111	Base		1
2	TS-1505051	Socket Head Cap Screw	M10 x 35	4
3	TS-1551071	Lock Washer	M10	4
4	TS-1550071	Flat Washer	M10 x 20	4
5	MA612002	Motor	1-1/2HP, 1 Ph, 60HZ	1
	PDS12CS-MFC	Motor Fan Cover (not shown)		1
	PDS12CS-MF	Motor Fan (not shown)		1
	PDS12CS-CS	Centrifugal Switch (not shown)		1
	PDS12CS-CC	Capacitor Cover (not shown)		1
	PDS12CS-JBC	Junction Box Cover (not shown)		1
	PDS12CS-SC	Starting Capacitor (not shown)	200MFD, 125VAC	
	PDS12CS-RC	Running Capacitor (not shown)	40uF, 250V	
6	411051	Switch Box		1
7	411053	Switch Plate		1
8	ST039304	Tapping Screw	M3.5x12 (AB)	6
9	SP059400	Pan Head Screw	M5 x 16	1
10	WE050000	Star Washer	M5	1
11	NF050800	Hex Flange Nut	M5	2
12	994505	Switch		1
13	SP059300	Pan Head Screw	M5 x 12	2
14	998621	Strain Relief		1
15	IC314101	Power Cord		1
16	TS-1490041	Cap Screw	M8 x 25	4
17	TS-1551061	Lock Washer	M8	4
18	TS-1550061	Flat Washer	M8 x 12	4
19	KD050535	Key	5 x 5 x 35	1
20	612114	Disc Guard		1
21	SJ080400	Pan Head Bolt	M8 x 20	4
22	612104	Pulley		1
23	VB-A39	V-Belt	A39	1
24	TS-1523031	Set Screw	M6 x 8	1
25	612120	Sanding Disc		1
26	612113	Washer		1
27	SM089400	Countersunk Head Bolt	M8 x 16	1
28	57698525	12" Disc Sanding Paper 36 Grit		25
	57698650	12" Disc Sanding Paper 50 Grit		50
	57698750	12" Disc Sanding Paper 60 Grit		50
	57698850	12" Disc Sanding Paper 80 Grit		50
	57698950	12" Disc Sanding Paper 100 Grit		50
	57699050	12" Disc Sanding Paper 120 Grit		50
29	612118	Brake Base		1
30	SP040200	Pan Head Bolt	M4 x 10	3
31	612116	Brake		1
32	PS042600	Spring Pin	4 x 26	1
33	612115	Stop Handle		1
34	612140	Spring		1
35	TS-1550031	Flat Washer	M5 x 12	1
36	612084	Front Cover		1
37	SF069200	Pan Head Flange Bolt	M6 x 8	2
38	150031	Pin		3
39	612035	Stop Bracket		1
40	TS-1550061	Flat Washer	M8 x 18	1

Index No.	Part No.	Description	Size	Qty
41	TS-1551061	Lock Washer	M8	1
42	TS-1490041	Cap Screw	M8 x 25	1
43	612010	Locating Block		1
44	TS-1540041	Nut	M6	1
45	TS-1523071	Set Screw	M6 x 25	1
46	PS052500	Spring Pin	5 x 25	1
47	612135-1	Table		1
48	612046	Trunnion		2
49	TS-1551061	Lock Washer	M8	4
50	TS-1490021	Cap Screw	M8 x 16	4
51	612054	Table Bracket		1
52	PS063000	Spring Pin	6 x 30	4
53	612038	Trunnion Holder (A)		1
54	612098	Knob	M8	2
55	SH081100	Hex Head Bolt	M8 x 55	2
56	TS-1540061	Nut	M8	1
57	TS-1504041	Socket Head Cap Screw	M8 x 20	1
58	TS-1550061	Flat Washer	M8 x 18	2
59	612052	Trunnion Holder (B)		1
60	612037	Table Bracket		1
61	TS-1490021	Cap Screw	M8 x 16	4
62	TS-1551061	Spring Washer	M8	4
63	TS-1550061	Flat Washer	8 x 18	4
64	150031	Pin		2
65	AB612143	Circle Gauge Assembly		1
66	AB612148	Miter Gauge Assembly		1
67	TS-1551061	Lock Washer	M8	4
68	TS-1551021	Lock Washer	M4	2
69	TS-1503041	Socket Head Cap Screw	M6 x 16	1
70	TS-1540041	Hex Nut	M6	1
71	L200000	Elastic		1
72	612171	Filler Bar		1
73	TS-1502011	Socket Head Cap Screw	M5x8	1
*	PDS12CS-HK	Hardware Kit (not shown)		
	PDS12CS-WL	Warning Label (not shown)		
	PDS12CS-ID	I.D. Label (not shown)		
	PDS12CS-JL	Powermatic Label (not shown)		

Wiring Diagram

