



SERVICE PARTS LIST

BUL. 54-10-4004

HOLE HAWG

REVISED BUL. 54-10-4003 DATE Feb. '75

Catalog No. 1675-1

Starting Serial No. **413-65185**

WIRING INSTRUCTIONS **58-01-0623**

Specify Catalog and Serial No. when ordering parts

300 Or 1200 R.P.M.

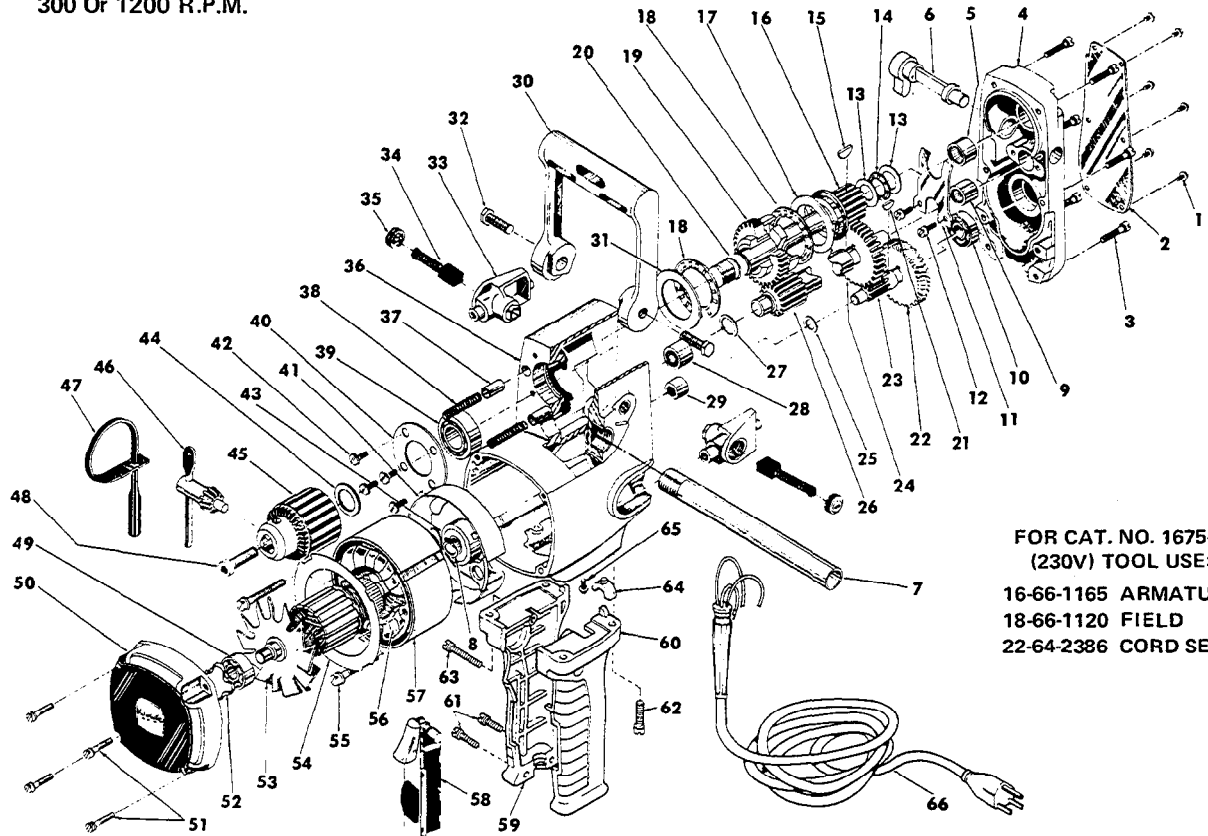

FOR CAT. NO. 1675-3
(230V) TOOL USE:
16-66-1165 ARMATURE
18-66-1120 FIELD
22-64-2386 CORD SET

FIG.	PART NO.	DESCRIPTION OF PART	NO. REQ.	FIG.	PART NO.	DESCRIPTION OF PART	NO. REQ.
1	06-81-8200	4-36x3/16 Rd. Hd. Name Plate Scr.	(6)	34	22-18-0450	Carbon Brush Assy.	(2)
2	12-98-7050	Name Plate	(1)	35	23-44-0130	Brush Retaining Cap	(2)
3	06-81-6350	8-32x1 Fil. Hd. Gear Case Cover Scr.	(6)	36	28-50-6121	Motor Housing Assy.	(1)
4	28-20-1121	Gear Case Cover	(1)	37	44-70-0160	Shifting Plunger	(2)
5	02-50-3170	Needle Bearing	(1)	38	40-50-7670	Shifting Spring	(2)
6	31-11-0100	Shifting Cam	(1)	39	02-04-1700	Ball Bearing	(1)
7	43-62-0120	Pipe Handle	(1)	40	44-66-5241	Bearing Retainer Plate	(1)
8	34-60-0827	Retaining Ring	(1)	41	31-55-0060	Coil Shield	(1)
9	02-50-2750	Needle Bearing	(1)	42	06-81-5400	8-32x5/16 Binder Hd. Brg. Ret. Scr.	(4)
10	02-04-0910	Ball Bearing	(1)	43	02-04-1050	Ball Bearing	(1)
11	45-98-0100	Shifting Yoke	(1)	44	45-88-0330	Chuck Spacer Washer	(1)
12	06-81-6050	8-32x5/16 Fil. Hd. Shifting Yoke Scr.	(2)	45	48-66-1380	Chuck	(1)
13	45-88-7150	Thrust Washer	(2)	46	48-66-3280	Chuck Key	(1)
14	02-80-6020	Thrust Bearing	(1)	47	48-66-4040	Key Holder	(1)
15	06-42-2000	No. 3 Woodruff Key	(1)	48	06-75-3150	1/4-20x1 L.H. Soc. Hd. Cap Screw	(1)
16	32-10-0132	Hi-Speed Clutch Gear Assy.	(1)	49	02-04-0940	Ball Bearing	(1)
17	45-88-7140	Thrust Washer	(1)	50	28-50-6111	Bearing Support Housing Assy.	(1)
18	02-80-1800	Thrust Bearing	(2)	51	06-81-6200	8-32x5/8 Fil.Hd.Brg. Support Hsg.Scr.	(4)
19	32-10-0122	Lo-Speed Clutch Gear Assy.	(1)	52	45-88-7110	Spring Washer	(1)
20	38-50-4991	Spindle	(1)	53	16-62-1165	Armature Assy. (incl. fig. 8)	(1)
21	06-42-1200	No. 212 Woodruff Key	(1)	54	42-14-0150	Baffle	(1)
22	32-42-1301	1st. Intermediate Gear	(1)	★ 55	06-81-6700	8-32x 1-7/8 Fil. Hd. Field Scr.	(2)
23	36-66-4071	1st. Intermediate Pinion	(1)	56	18-62-1120	Field Assy.	(1)
24	32-44-1311	2nd. Intermediate Gear	(1)	57	23-16-0430	Field Insulator	(1)
25	45-88-7100	Fiber Thrust Washer	(1)	★ 58	23-66-0481	Switch	(1)
26	36-66-4081	2nd. Intermediate Pinion	(1)	★ 59	31-44-0500	R.H. Drill Handle	(1)
27	45-88-7095	Fiber Thrust Washer	(1)	★ 60	31-44-0510	L.H. Drill Handle	(1)
28	02-50-3180	Needle Bearing	(1)	61	06-81-6200	8-32x5/8 Fil.Hd. Handle Cover Scr.	(2)
29	02-50-2020	Needle Bearing	(1)	62	06-81-7560	12-24x7/8 Fil.Hd. Handle Ret. Scr.	(4)
30	28-44-7151	Spade Handle	(1)	63	06-81-6400	8-32x1 1/8 Fil.Hd. Handle Cover Scr.	(1)
31	45-88-0520	Thrust Washer	(1)	64	31-55-0070	Power Cord Shield	(1)
32	45-04-0380	3/8-16x1 Hex Hd. Spade Handle Scr.	(2)	65	06-81-8625	6-32x1/4 Ground Scr.	(1)
33	22-22-0281	Brush Holder Assy.	(2)	★ 66	22-64-0386	Cord Set	(1)
				67	12-98-7081	Caution Plate (Not Shown)	