



SERVICE PARTS LIST

BULLETIN NO.
54-10-4038

SPECIFY CATALOG NO. AND SERIAL NO. WHEN ORDERING PARTS		REVISED BULLETIN	DATE
SINGLE SPEED HOLE HAWG®		54-10-4037	Mar. 2005
CATALOG NO. 1670-1	STARTING SERIAL NO. 472D	WIRING INSTRUCTION 58-01-0626	

00
0

EXAMPLE:
Component Parts (Small #) Are Included
When Ordering The Assembly (Large #).

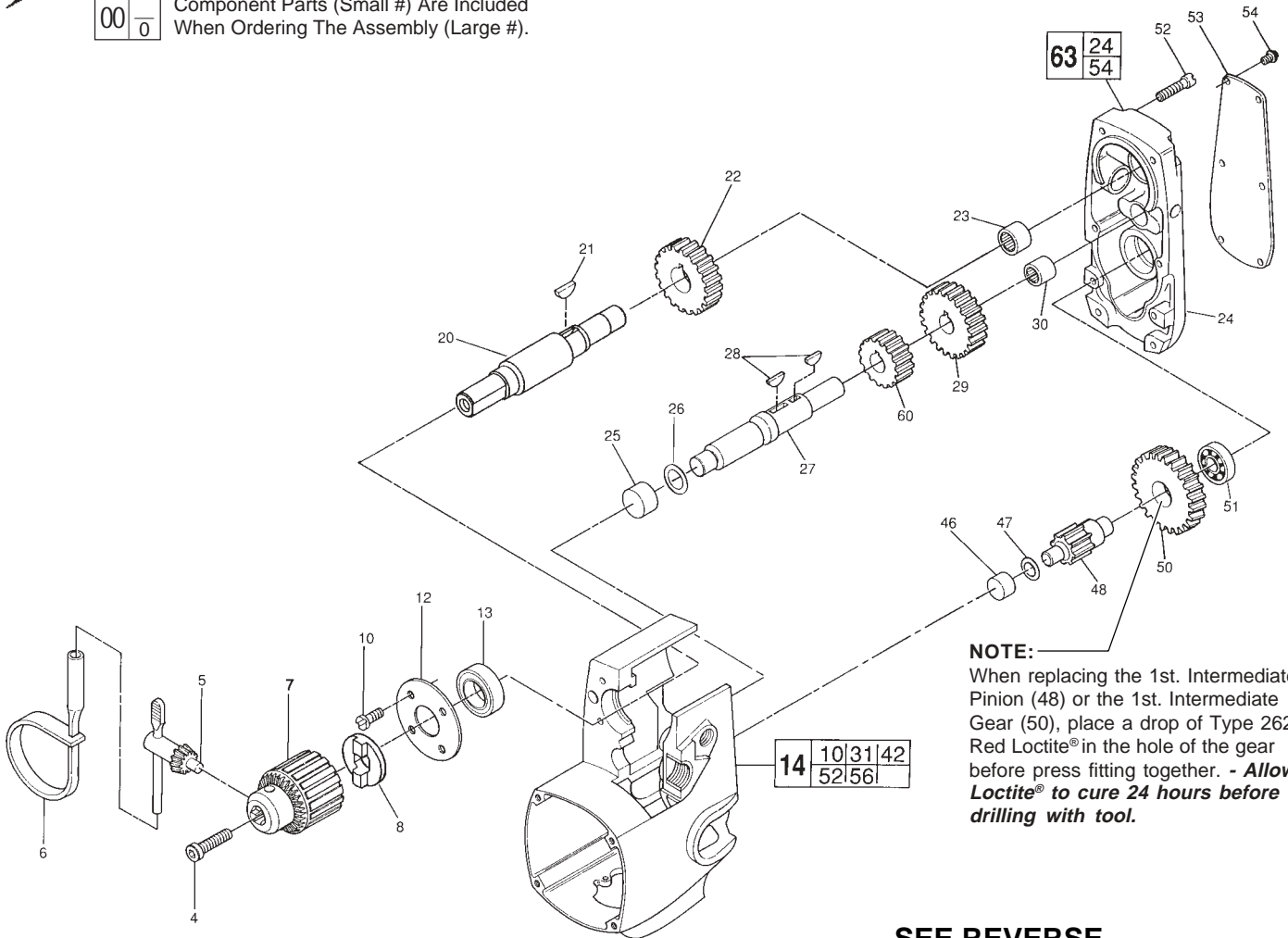

NOTE:
When replacing the 1st. Intermediate Pinion (48) or the 1st. Intermediate Gear (50), place a drop of Type 262 Red Loctite® in the hole of the gear before press fitting together. - **Allow Loctite® to cure 24 hours before drilling with tool.**

SEE REVERSE SIDE

FIG.	PART NO.	DESCRIPTION OF PART	NO. REQ.	FIG.	PART NO.	DESCRIPTION OF PART	NO. REQ.
	4	06-75-3155 1/4-20 x 1" L.H. Soc. Hd. Cap Screw	(1)	★	50	32-42-1302 1st. Intermediate Gear	(1)
	5	48-66-3280 Chuck Key	(1)		51	02-04-0910 Ball Bearing	(1)
	6	48-66-4040 Key Holder	(1)		52	06-82-5362 8-32 x 1" Pan Hd. T-20 Screw	(6)
	7	48-66-1481 Chuck	(1)		53	12-98-7295 Service Nameplate	(1)
	8	43-78-0670 Drive Hub	(1)		54	06-82-5266 4-40 x 1/4" Pan Hd. T-10 Screw	(6)
	10	06-82-7252 8-32 x 3/8" Pan Hd. T-20 Screw	(4)		60	32-40-1970 2nd Intermediate Gear	(1)
	12	44-66-5241 Bearing Retainer Plate	(1)		63	28-20-1127 Gear Case Assembly	(1)
	13	02-04-1700 Ball Bearing	(1)				
	14	28-50-6129 Motor Housing Assembly	(1)				
	20	38-50-5075 Spindle	(1)				
	21	06-42-2000 Woodruff Key	(1)				
	22	32-75-2210 Spindle Gear	(1)				
	23	02-50-3170 Needle Bearing	(1)				
	24	28-20-1252 Gear Case Cover	(1)				
	25	02-50-3180 Needle Bearing	(1)				
	26	45-88-7095 Fiber Thrust Washer	(1)				
	27	36-66-4400 2nd. Intermediate Shaft	(1)				
	28	06-42-1900 Woodruff Key	(2)				
	29	32-44-1190 2nd. Intermediate Gear	(1)				
	30	02-50-2750 Needle Bearing	(1)				
	46	02-50-2020 Needle Bearing	(1)				
	47	45-88-7100 Fiber Thrust Washer	(1)				
★	48	36-66-1311 1st. Intermediate Pinion	(1)				

FIG. 4 NOTES
Torque to 150-155 in./lbs.

FIG. 24 LUBRICATION
3-1/2 oz. Type "E" Grease, No. 49-08-4122.
Pre-lube all needle bearings with Type "E" Grease, No. 49-08-4122.

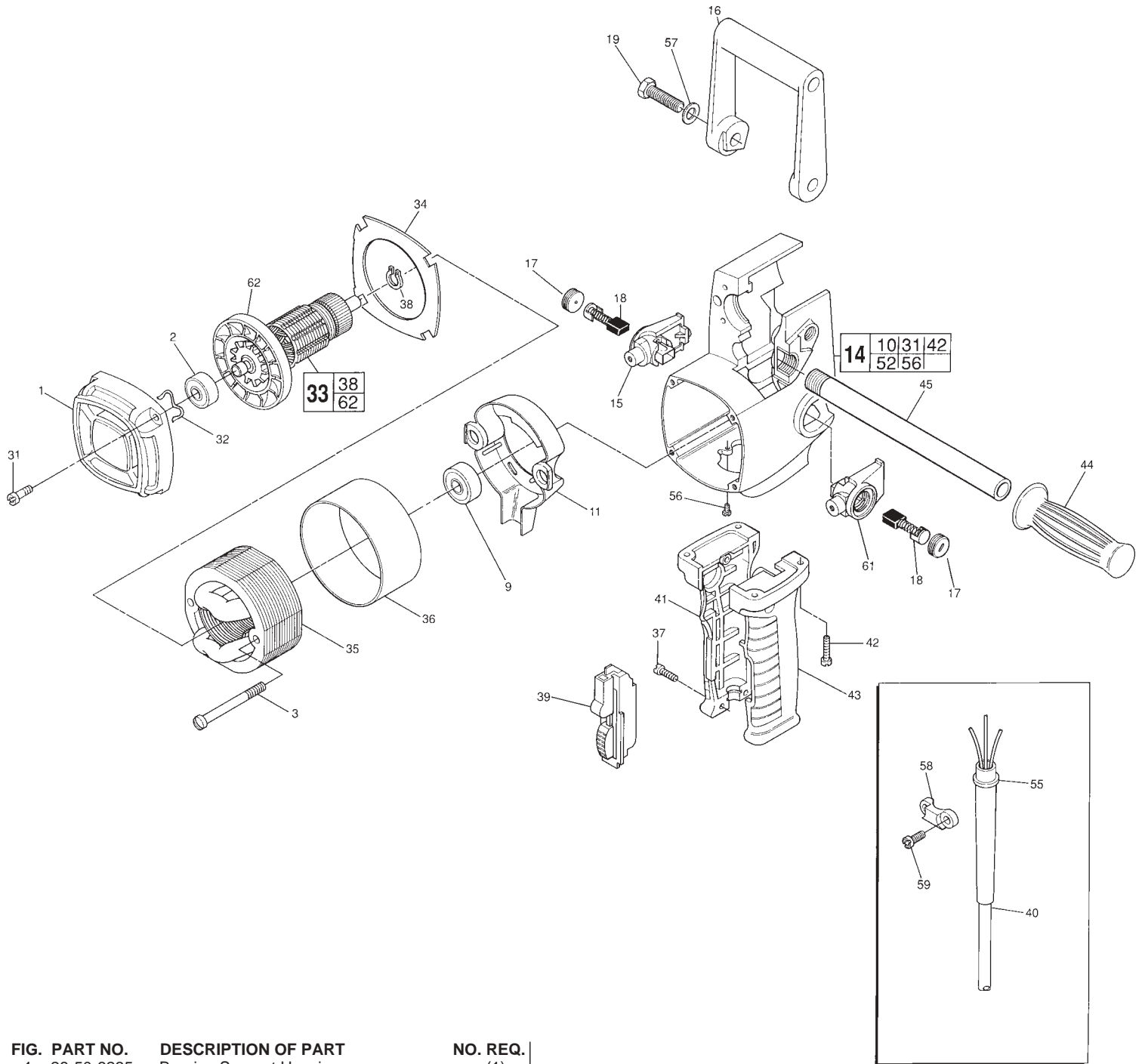

FIG.	PART NO.	DESCRIPTION OF PART	NO. REQ.
1	28-50-6235	Bearing Support Housing	(1)
2	02-04-0913	Ball Bearing	(1)
3	06-82-7410	8-16 x 1-7/8" Pan Hd. Plastite T-20 Screw	(2)
9	02-04-1050	Ball Bearing	(1)
11	31-55-0065	Coil Shield	(1)
14	28-50-6129	Motor Housing Assembly	(1)
15	22-22-1350	R.H. Brush Holder Assembly	(2)
16	31-44-1100	Spade Handle	(1)
17	23-44-0220	Brush Retaining Cap	(2)
18	22-18-0670	Carbon Brush Assembly	(2)
19	06-75-0500	3/8-16 x 1" Hex Hd. Spade Handle Screw	(2)
31	06-82-5346	8-32 x 3/4" Pan Hd. T-20 Screw	(4)
32	45-88-7110	Spring Washer	(1)
33	16-50-1076	Armature Assembly	(1)
34	42-14-0150	Baffle	(1)
35	18-50-0076	Field Assembly	(1)
36	23-16-0425	Field Insulator	(1)
37	06-82-7326	8-16 x 1" Plastite T-20 Screw	(3)
38	34-60-0827	Retaining Ring	(1)
39	23-66-1020	Switch	(1)

FIG.	PART NO.	DESCRIPTION OF PART	NO. REQ.
40	22-64-0121	Cord Set	(1)
41	31-44-1441	R.H. Drill Handle	(1)
42	06-82-5382	1/4-20 x 3/4" Pan Hd. Taptite T-27 Screw	(4)
43	31-44-1446	L.H. Drill Handle	(1)
44	43-62-0246	Handle Grip	(1)
45	43-62-0122	Pipe Handle	(1)
55	44-76-0150	Cord Protector	(1)
56	06-95-5150	6-32 x 1/4" Ground Screw	(1)
57	45-88-0605	Flat Washer	(2)
58	31-17-0155	Cord Clamp	(1)
59	06-82-7270	8-16 x 5/8" Pan Hd. Slit. T-20 Plastite Screw	(2)
61	22-22-1355	L.H. Brush Holder Assembly	(1)
62	22-84-0660	Fan Assembly	(1)
	10-98-5986	Caution Label	(1)