



SERVICE PARTS LIST

BULLETIN NO.
54-10-4032

SPECIFY CATALOG NO. AND SERIAL NO. WHEN ORDERING PARTS		REVISED BULLETIN	DATE
SINGLE SPEED HOLE HAWG®		54-10-40351	June '99
CATALOG NO. 1670-1	STARTING SERIAL NO. 472-23375	WIRING INSTRUCTION 58-01-0626	

EXAMPLE:



Component Parts (Small #) Are Included When Ordering The Assembly (Large #).

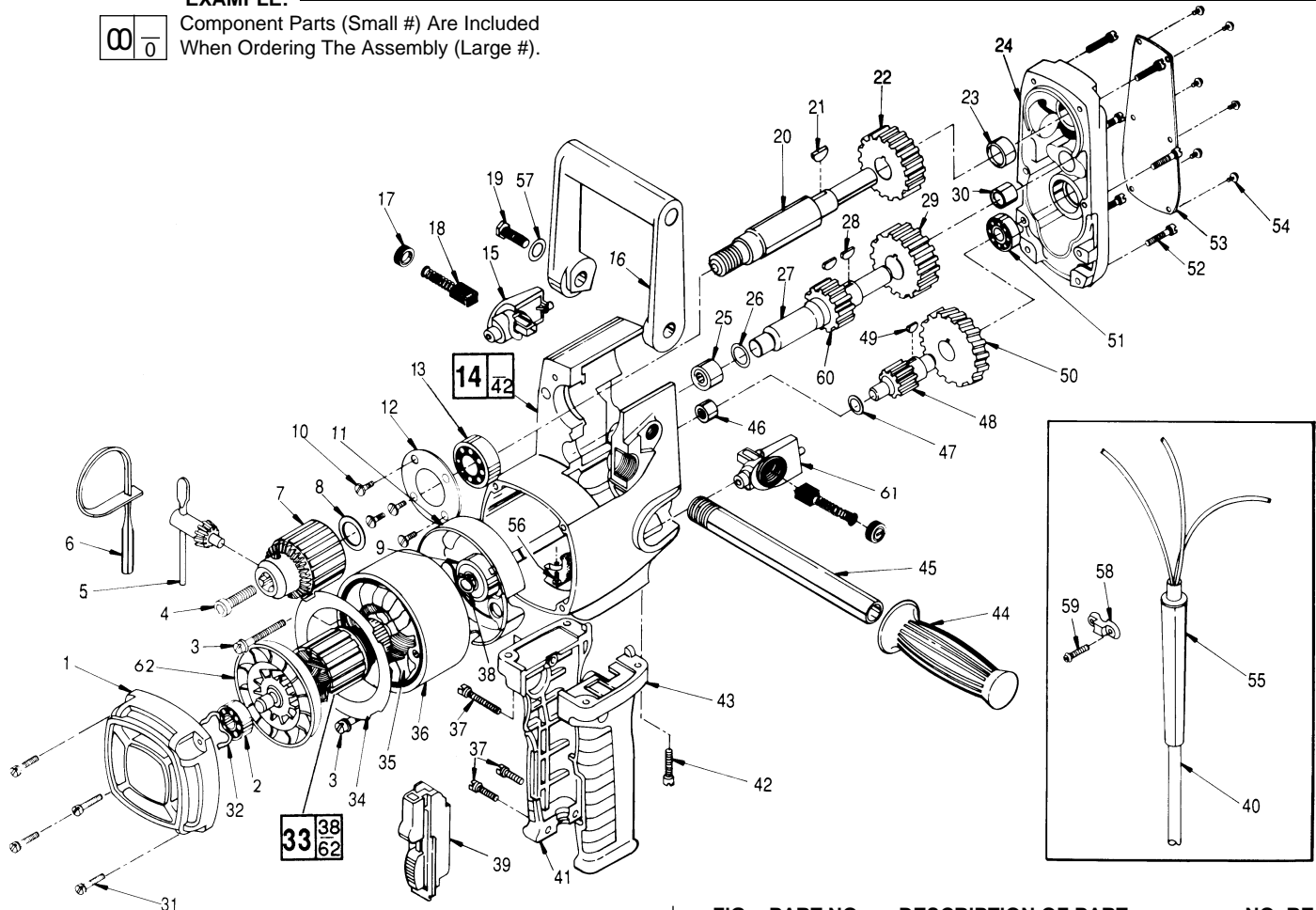

FIG.	PART NO.	DESCRIPTION OF PART	NO. REQ.
	1	28-50-6235 Bearing Support Housing	(1)
	2	02-04-0911 Ball Bearing	(1)
	3	06-95-3285 8-16 x 1-3/16" Pan Hd. Plastite Screw	(2)
	4	06-75-3150 1/4-20 x 1" L.H. Soc. Hd. Cap Screw	(1)
	5	48-66-3280 Chuck Key	(1)
	6	48-66-4040 Key Holder	(1)
★	7	48-66-1381 Chuck	(1)
	8	45-88-0330 Chuck Spacer Washer	(1)
	9	02-04-1050 Ball Bearing	(1)
	10	06-81-5502 8-32 x 3/8" Comb. Phil. Hd. Sem.	(4)
	11	31-55-0065 Coil Shield	(1)
	12	44-66-5241 Bearing Retainer Plate	(1)
	13	02-04-1700 Ball Bearing	(1)
★	14	28-50-6127 Motor Housing Assembly	(1)
★	15	22-22-1350 R.H. Brush Holder Assembly	(1)
	16	31-44-1100 Spade Handle	(1)
★	17	23-44-0220 Brush Retaining Cap	(2)
★	18	22-18-0670 Carbon Brush Assembly	(2)
	19	06-75-0500 3/8-16 x 1" Hex Hd. Spade Handle Screw	(2)
	20	38-50-5070 Spindle	(1)
	21	06-42-2000 Woodruff Key	(1)
	22	32-75-2210 Spindle Gear	(1)
	23	02-50-3170 Needle Bearing	(1)
	24	28-20-1123 Gear Case Cover	(1)
	25	02-50-3180 Needle Bearing	(1)
	26	45-88-7095 Fiber Thrust Washer	(1)
	27	36-66-4400 2nd. Intermediate Shaft	(1)
	28	06-42-1900 Woodruff Key	(2)
	29	32-44-1190 2nd. Intermediate Gear	(1)
	30	02-50-2750 Needle Bearing	(1)
	31	06-81-6202 8-32 x 5/8" Fil. Hd. Brg. Support Hsg. Screw	(4)
	32	45-88-7110 Spring Washer	(1)
	33	16-50-0070 Armature Assembly	(1)
	34	42-14-0150 Baffle	(1)
★	35	18-50-0075 Field Assembly	(1)

FIG.	PART NO.	DESCRIPTION OF PART	NO. REQ.
	36	23-16-0425 Field Insulator	(1)
	37	06-82-7326 8-16 x 1" Plastite T-20 Screw	(3)
	38	34-60-0827 Retaining Ring	(1)
	39	23-66-1020 Switch	(1)
	40	22-64-0121 Cord Set	(1)
	41	31-44-1440 R.H. Drill Handle	(1)
	42	06-82-5358 12-24 x 3/4" Pan Hd. Taptite Screw	(4)
	43	31-44-1445 L.H. Drill Handle	(1)
	44	43-62-0246 Handle Grip	(1)
	45	43-62-0122 Pipe Handle	(1)
	46	02-50-2020 Needle Bearing	(1)
	47	45-88-7100 Fiber Thrust Washer	(1)
	48	36-66-1310 1st. Intermediate Pinion	(1)
	49	06-42-0800 Woodruff Key	(1)
	50	32-42-1301 1st. Intermediate Gear	(1)
	51	02-04-0910 Ball Bearing	(1)
	52	06-81-6350 8-32 x 1" Fil. Hd. Gear Case Cover Screw	(6)
	53	12-98-7045 Service Nameplate	(1)
	54	06-81-8400 4-40 x 1/4" Rd. Hd. Nameplate Screw	(6)
	55	44-76-0150 Cord Protector	(1)
	56	06-81-8625 6-32 x 1/4" Ground screw	(1)
	57	45-88-0605 Flat Washer	(2)
	58	31-17-0156 Cord Clamp	(1)
★	59	06-82-7270 8-16 x 5/8" Pan Hd. Slit Torx Plastite Screw	(2)
	60	32-40-1970 2nd Intermediate Gear	(1)
★	61	22-22-1355 L.H. Brush Holder Assembly	(1)
	62	22-84-0660 Fan Assembly	(1)
		10-98-5986 Caution Label	(1)

FIG. LUBRICATION
24 4 oz. Type "E" Grease, No. 49-08-4122.
Prelube all needle bearings with Type "E" Grease, No. 49-08-4122.

MILWAUKEE ELECTRIC TOOL CORPORATION
13135 W. LISBON RD., BROOKFIELD, WI 53005