

Cordless Screwdriver - F 012 257 000 - 144 VXT

Item	Part Number	Description	Illustration	Price	Quantity	Price Group
1	2 610 997 743	Housing Set	1	-,-	1	-
3	2 610 967 133	Pinion	1	-,-	1	11
4	2 607 200 442	On-Off Switch	1	-,-	1	-
5	2 610 997 745	Reverse-Transfer Lever	1	-,-	1	-
8	2 610 998 860	Nameplate	1	-,-	1	-
9	2 610 997 851	Label	1	-,-	1	-
19	2 610 909 719	Screw BLACK	1	-,-	7	11
20	2 610 997 850	Warning Plate	1	-,-	1	-
25	2 610 993 339	Keyless Chuck	1	-,-	1	-
29	2 610 997 746	Housing Cover	1	-,-	1	-
45	2 610 913 459	Gear Box	1	-,-	1	-
96	2 610 911 815	Bit holder	1	-,-	1	-
107	2 609 110 721	Countersunk-Head Screw M5x20	1	-,-	1	11
651	2 607 335 331	. 14,4V, 1,0Ah, NiCd	1	-,-	1	-
652	2 610 998 246	Adapter	1	-,-	1	-
653	2 610 998 217	Charging Transformer MAL 230/12V, 1h	1	-,-	1	-
802	2 610 998 225	Motor 14,4V	1	-,-	1	-

Illustration - Type E

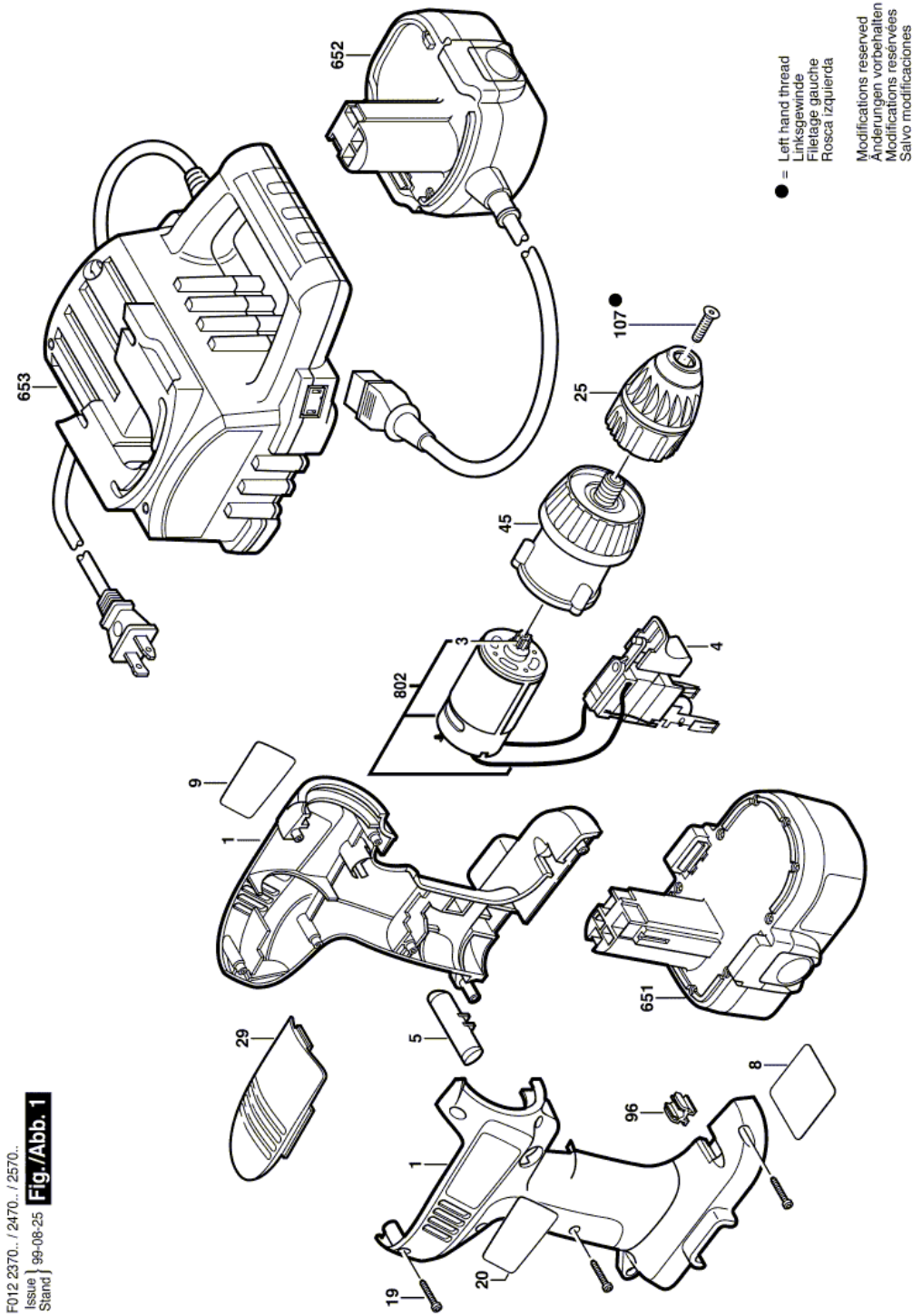

F012.2370... / 2470... / 2570...
 Issue | 99-08-25 **Fig./Abb. 1**
 Stand

Information subject to change without further notice.