

Cutting Components

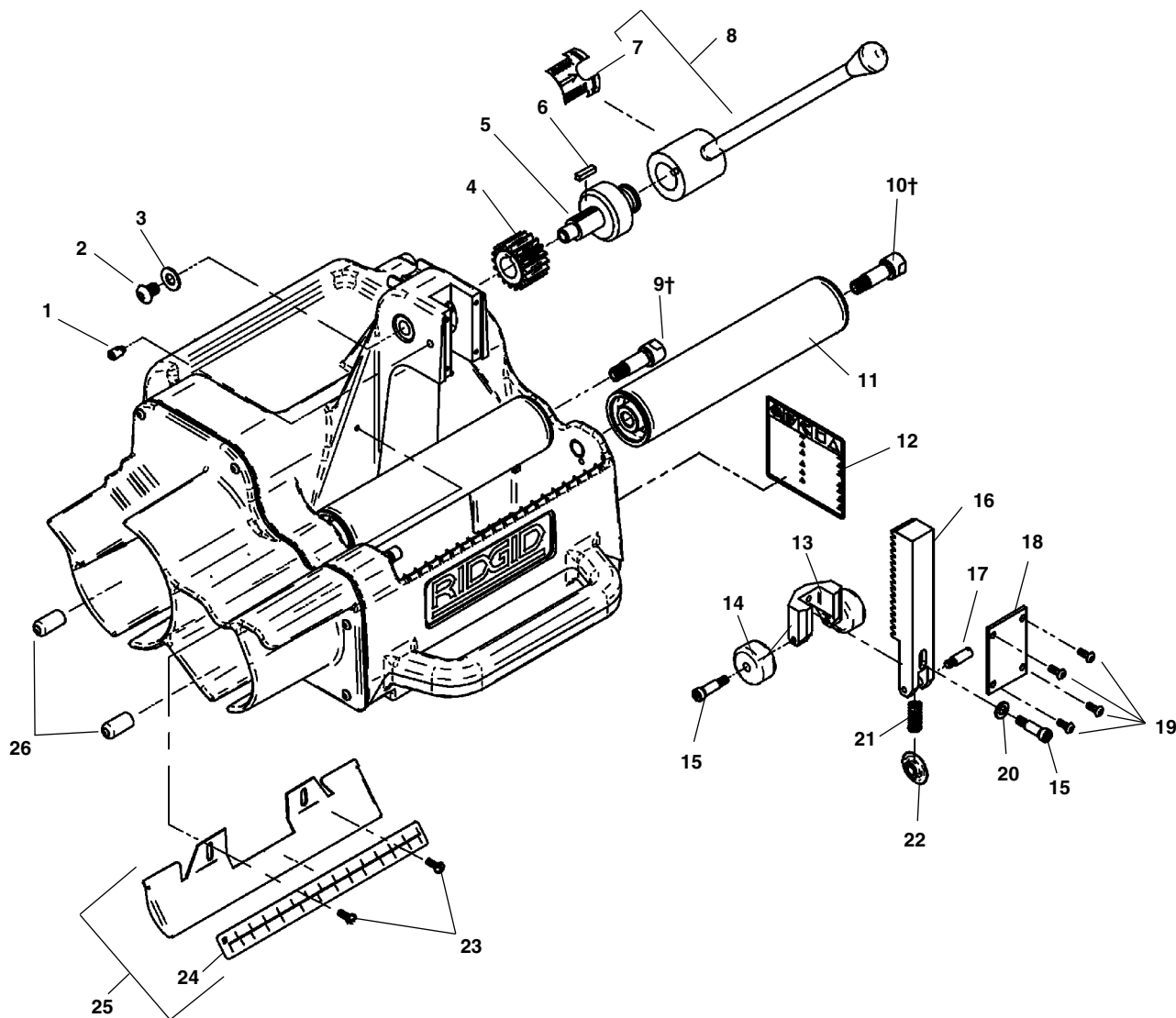

**NOTE: Order parts by Catalog Number only.
DO NOT order by Reference Number.**

Ref. No.	Catalog No.	Description	Ref. No.	Catalog No.	Description
1	94877	Set Screw, Nylon $\frac{5}{16}$ " - 18 x $\frac{1}{2}$ "	15	94922	Screw, Shoulder $\frac{5}{16}$ " x $\frac{3}{4}$ " (3)
2	96915	Screw, Button Head $\frac{3}{8}$ " - 16 x $\frac{1}{2}$ "	16	94937	Arbor
3	26307	Washer	17	34360	Screw f/Cutter Wheel
4	94882	Gear, Arbor	10343	94947	Screw f/Cutter Wheel (SS)
5	94887	Shaft, Arbor	18	94947	Cover
6	94892	Key, Square $\frac{3}{16}$ " x $\frac{3}{4}$ "	19	94752	Screw, Phillips #10 - 24 x $\frac{3}{4}$ " (4)
7	14393	Indexing Label	20	94952	Washer
8	94897	Handle, Feed	21	94942	Spring
9†	94907	Shaft, L.H. Thread	22	33175	Cutter Wheel, E-2191
10†	94912	Shaft, L.H. Thread	33551	94927	Cutter Wheel (SS)
11	94902	Roller Assembly (2)	23	45275	Screw (2)
12	10398	Warning Label	24	10393	Scale
13	94932	Slide	25	10388	Roller Guard
14	94927	Roller (2)	26	10573	Plastic Cap (2) (Europe Only)

Service Note: † Left Hand Thread

Electrical

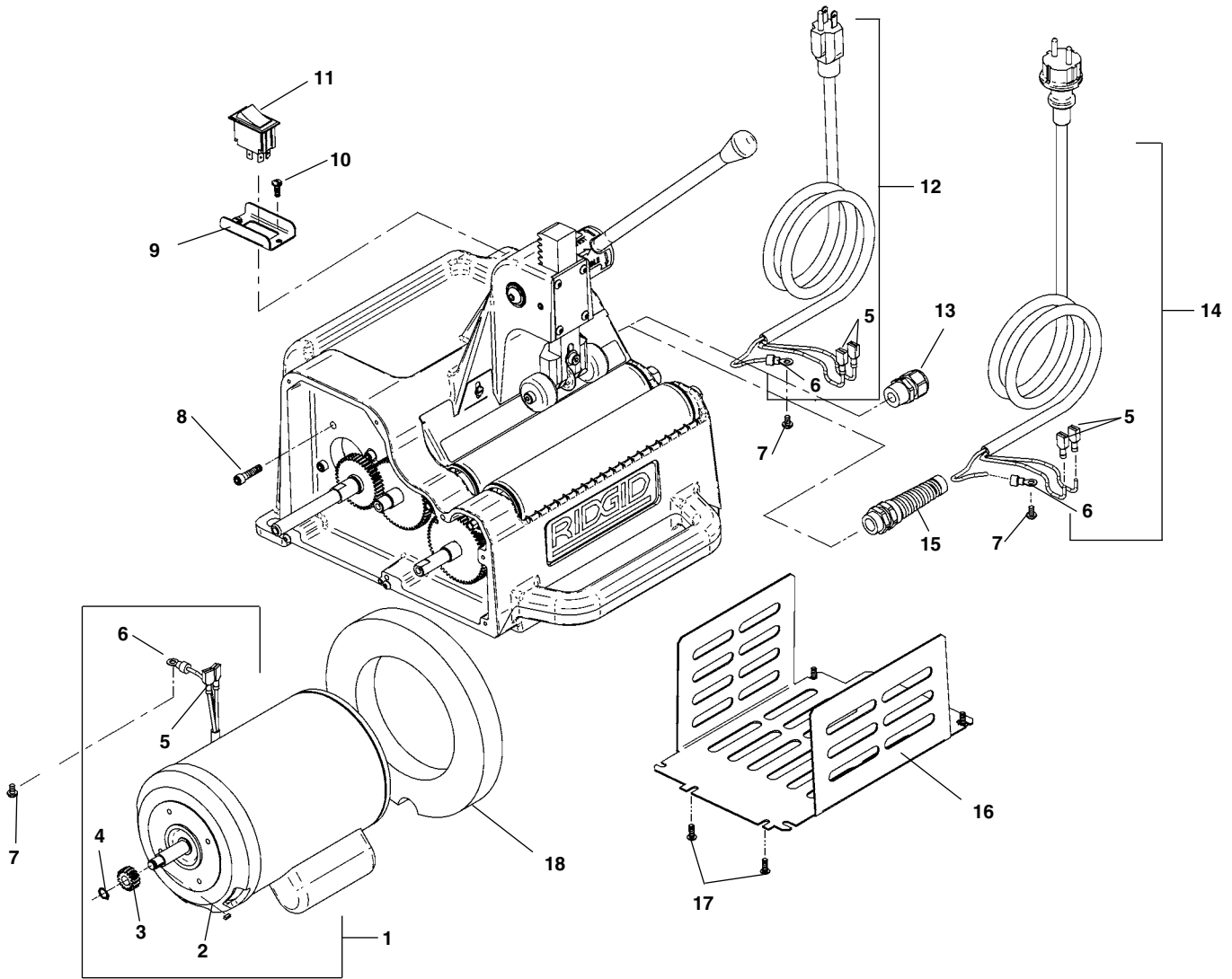

**NOTE: Order parts by Catalog Number only.
DO NOT order by Reference Number.**

Ref. No.	Catalog No.	Description	Ref. No.	Catalog No.	Description
1	94842	Motor, 1/3 H.P. - 115V	10	45275	Screw (2)
2	10403	Motor 220V 50Hz (Europe)	11	58597	Switch, DPST
3	94787	Key, Square 3/32" x 1/4"	12	69327	Line Cord 115V
4	94847	Gear	13	69107	Strain Relief
5	94822	Retaining Ring	14	39562	Line Cord 220V 50Hz (Europe)
6	89190	Female Disconnect (4)	15	27187	Strain Relief (Europe)
7	58587	Terminal Ring (2)	16	94862	Motor Cover
8	45420	Ground Screw #10 - 24 x 3/8" (2)	17	94752	Screw, Phillips #10 - 24 x 3/4" (4)
9	83685	Screw, Socket Head 1/4" - 20 (4)	18	94667	Motor Baffle
10	10408	Switch Guard			

Prep Components

**NOTE: Order parts by Catalog Number only.
DO NOT order by Reference Number.**

Ref. No.	Catalog No.	Description
1	94662	Hex Nut 1/2" - 13
2	94667	Washer 1/2"
3	94682	Brush
4	94672	Spacer
5	94957	Grommet (7)
6	38940	Screw 1/4" - 20 x 5/8" (2)
7	93712	Fitting Brush Holder
8	94747	Reamer Guard
9	46080	Set Screw 5/16" - 18 x 1" (2)
10	94687	Reamer Cone
11	94692	Reamer Blade
12	46180	Screw, Socket Head #10 - 32 x 3/8" (2)

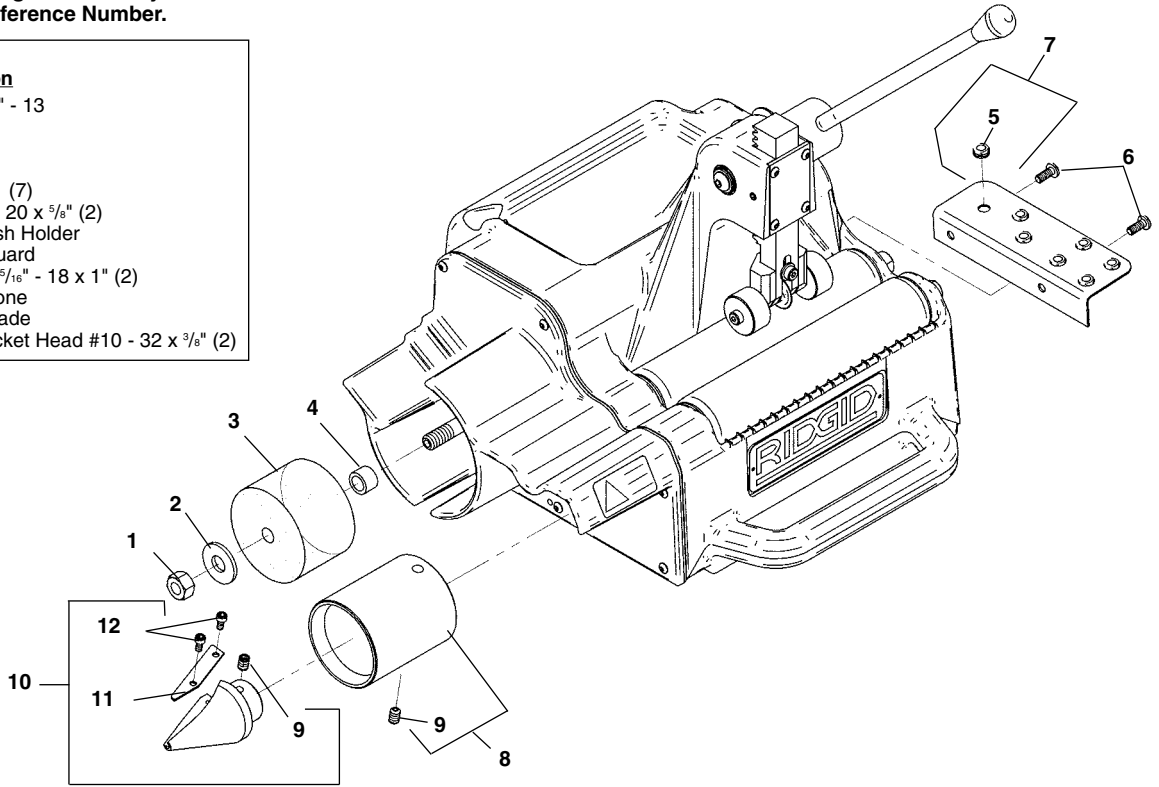

Gearbox

Ref. No.	Catalog No.	Description
1	94752	Screw, Phillips #10-24 x 3/4" (10)
2	94647	Gear Cover
3	94782	Brush, Shaft
4	94787	Key, Square 3/32" x 1/4" (4)
5	94792	Gear, Brush
6	94797	Gear Reduction
7	94847	Gear, Motor
8	94822	Retaining Ring (3)
9	94812	Gear, Reamer (2)
10	94807	Key, Square 1/8" x 1/4"
11	94802	Shaft
12†	94832	Shaft, Stub, Driven L.H. Thread (2)
13	94827	Gear, Roller (2)
14	94817	Shaft, Reamer

Service Note: † Left Hand Thread

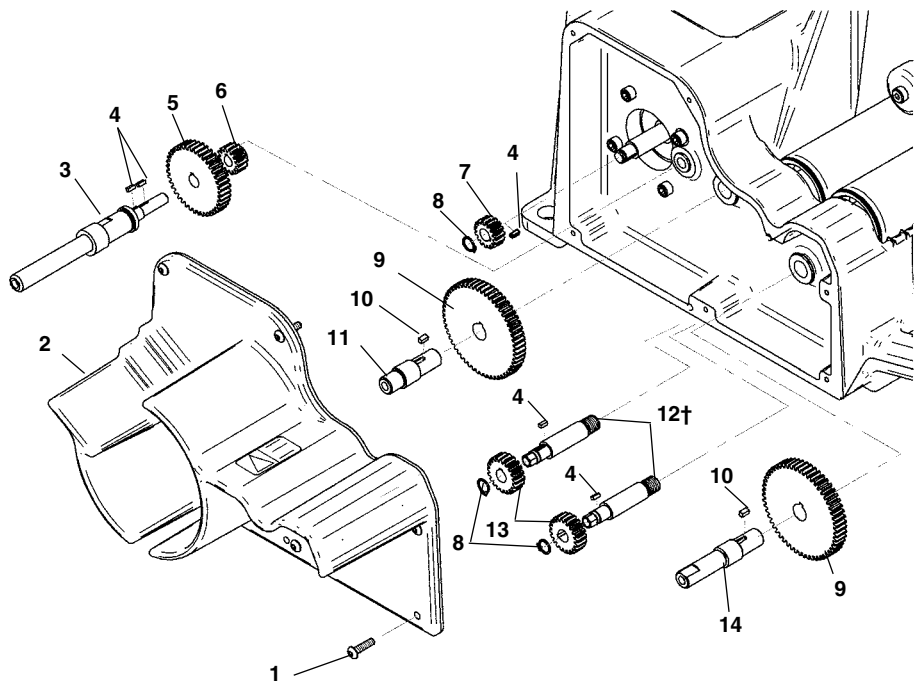

Body

**NOTE: Order parts by Catalog Number only.
DO NOT order by Reference Number.**

Ref. No.	Catalog No.	Description
—	94637	Frame Assembly
1	94642	Bearing, Flange (7)
2	94657	Bearing, Flange
3	45165	Dowel Pin (2)
4	94917	Plate, RIDGID logo
5	95392	Label, Warning

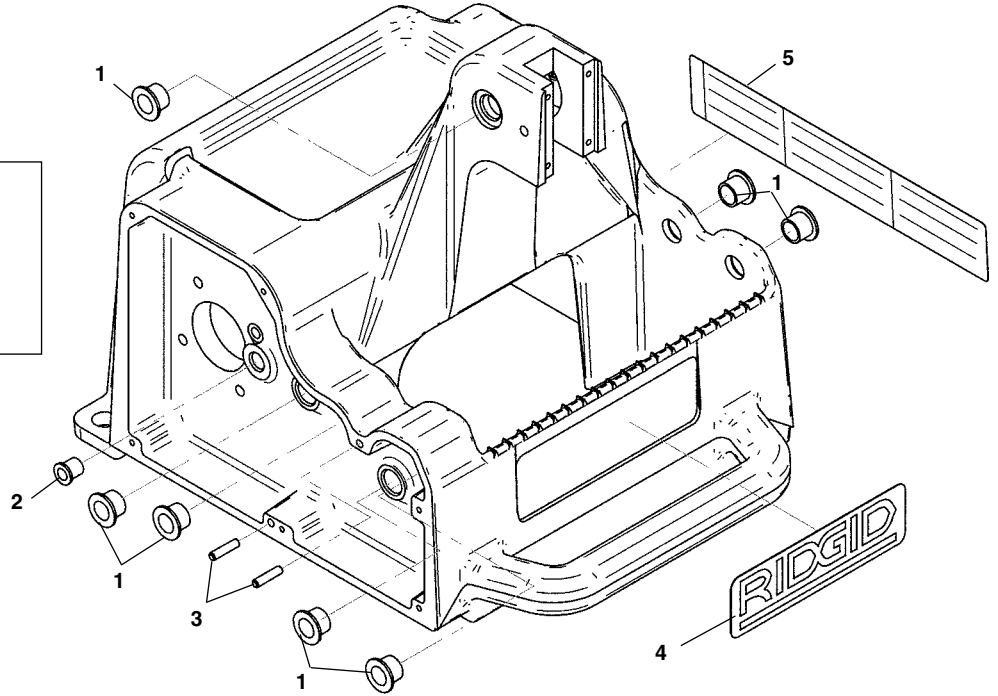

Gear Cover

Ref. No.	Catalog No.	Description
—	94647	Gear Cover
1	94642	Bearing, Flange (2)
2	94657	Bearing, Flange
3	94867	Label, Warning

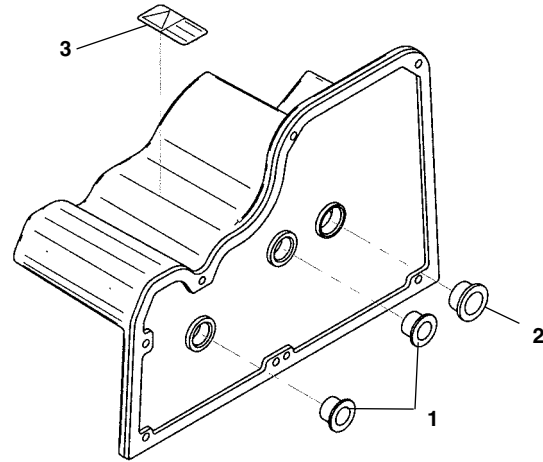

Wiring Diagram - Variations

115V – 60Hz
100V – 50/60Hz
(220 – 240V/50Hz)

