



# SERVICE PARTS LIST

**BULLETIN NO.**  
**54-05-0807**

SPECIFY CATALOG NO. AND SERIAL NO. WHEN ORDERING PARTS		REVISED BULLETIN 54-05-0806	DATE Sept. 2015
<b>CORDLESS M18™ COMPACT BLOWER</b>			
CATALOG NO. <b>0884-20</b>	STARTING SERIAL NO. <b>F74C</b>	WIRING INSTRUCTION <b>See Page 2</b>	

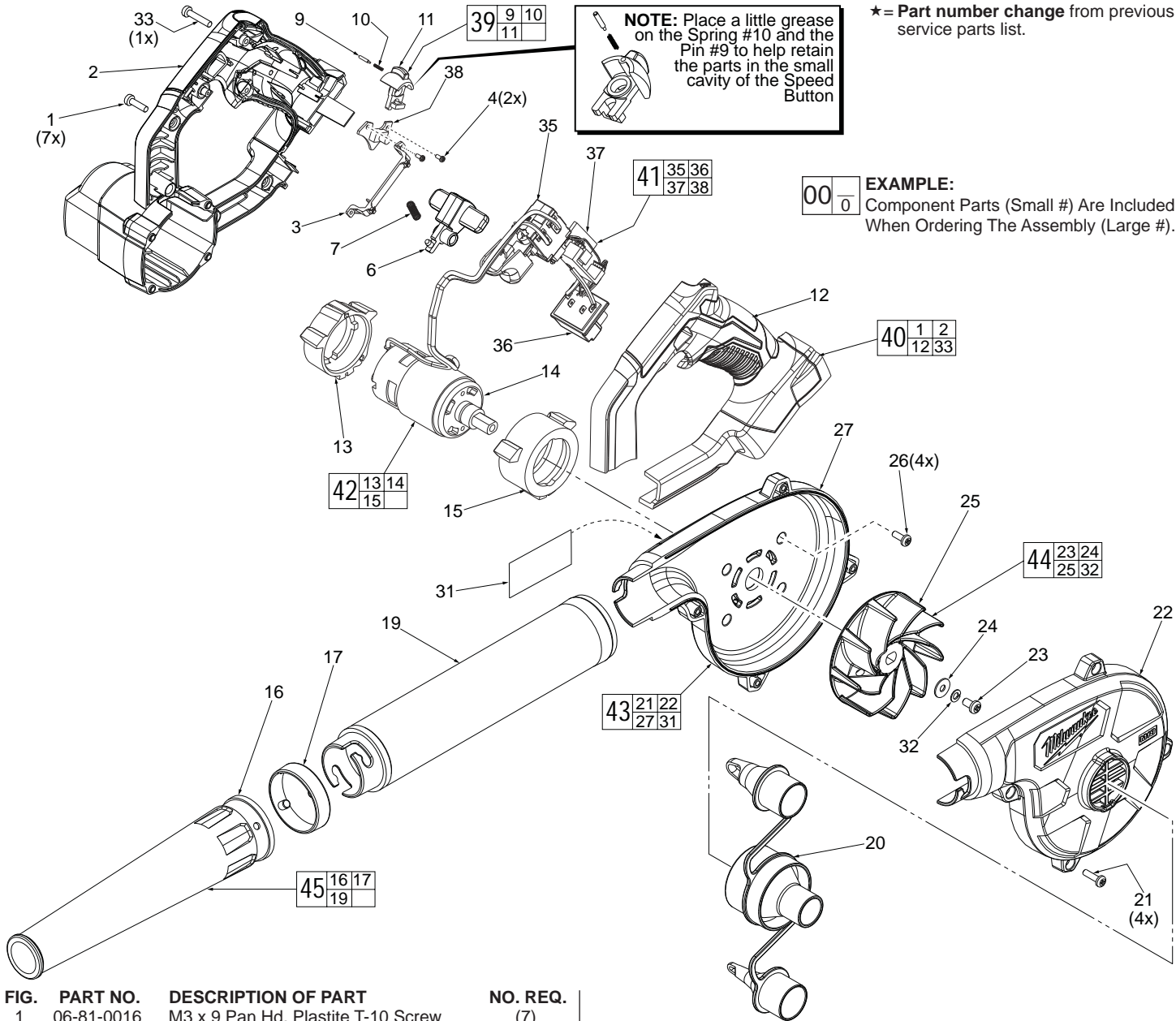

FIG.	PART NO.	DESCRIPTION OF PART	NO. REQ.
1	06-81-0016	M3 x 9 Pan Hd. Plastite T-10 Screw	(7)
★ 2	-----	Handle/Motor Housing Halve-Right	(1)
3	31-17-0130	Wire Trap	(1)
4	06-81-0026	M2.3 x 6 Pan Hd. Plastite Phillips Screw	(2)
★ 6	42-42-0806	Switch Lock Button	(1)
7	40-50-0206	Switch Lock Spring	(1)
9	-----	Speed Button Detent Pin	(1)
10	-----	Speed Button Spring	(1)
11	-----	Speed Button	(1)
★ 12	-----	Handle Housing Halve-Left	(1)
13	44-34-0450	Lower Motor Support	(1)
14	-----	Motor with Spindle	(1)
15	44-34-0455	Upper Motor Support	(1)
16	43-24-0511	Nozzle	(1)
17	44-90-1041	Nozzle Ring	(1)
19	43-24-0155	Extension Tube	(1)
20	45-80-0020	Inflator/Deflator Valves	(1)
21	06-81-0056	M4 x 18 Pan Hd. Plastite T-20 Screw	(4)
22	-----	Fan Housing Halve-Left	(1)
23	05-83-0400	M5.0 x 8 Pan Hd. Phillips Machine Screw	(1)
24	45-88-0013	Washer	(1)
25	-----	Fan	(1)
26	06-81-0066	M4.0 x 10 Pan Hd. Plastite Phillips Screw	(4)

FIG.	PART NO.	DESCRIPTION OF PART	NO. REQ.
27	-----	Fan Housing Halve-Right	(1)
31	12-20-0884	Service Nameplate	(1)
32	06-97-0040	Lock Washer	(1)
33	06-81-0017	M3 x 15 Pan Hd. Plastite T-10 Screw	(1)
35	-----	On-Off Switch	(1)
36	-----	Battery Connector Block	(1)
37	-----	Main PCBA	(1)
38	-----	Switch PCBA	(1)
39	31-01-1010	Blower Speed Button Assembly	(1)
★ 40	14-34-1027	Handle/Motor Housing Assembly	(1)
41	14-20-2000	Electronics Assembly	(1)
42	14-50-1300	Consists of On-Off Switch, Main PCBA, PCBA Switch, Battery Terminal Block	(1)
43	14-38-1010	Motor Assembly with Spindle	(1)
44	22-84-0080	Fan Housing Assembly	(1)
45	43-24-0521	Blower Fan Kit	(1)
		Nozzle/Extension Assembly	(1)

**MILWAUKEE ELECTRIC TOOL CORPORATION**  
13135 W. LISBON RD., BROOKFIELD, WI 53005  
Drwg. 1