



SERVICE PARTS LIST

BULLETIN NO.
54-24-0830

SPECIFY CATALOG NO. AND SERIAL NO. WHEN ORDERING PARTS		REVISED BULLETIN	DATE
18 VOLT 1/2" HAMMER-DRILL			Oct. 2011
CATALOG NO. 0824-20	STARTING SERIAL NO. A99A	WIRING INSTRUCTION SEE REVERSE SIDE	

EXAMPLE:
Component Parts (Small #)
Are Included When Ordering
The Assembly (Large #).

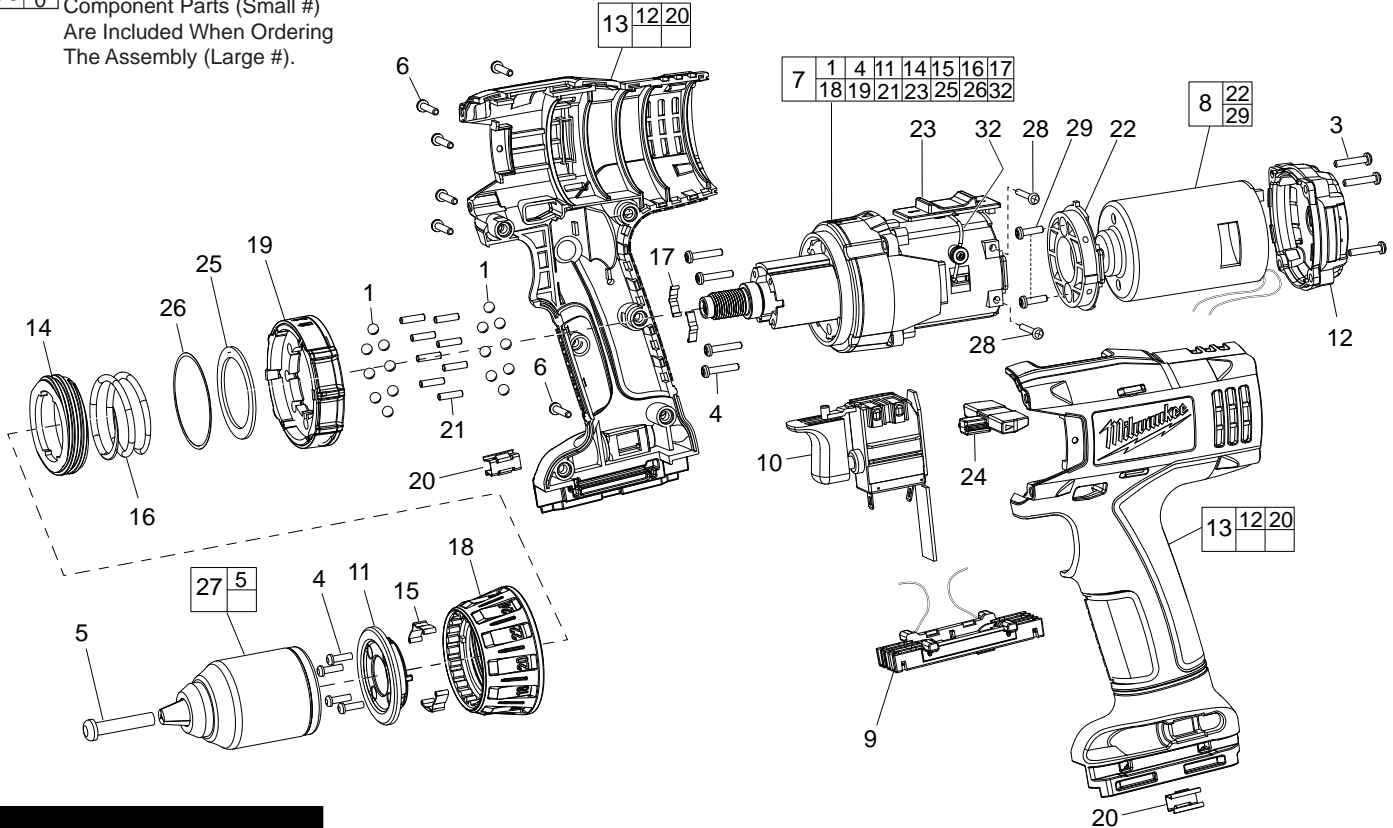

**SEE REVERSE SIDE
FOR SERVICE &
GREASE NOTES**

FIG.	PART NO.	DESCRIPTION OF PART	NO. REQ.
1	02-02-1300	Clutch Ball	16
3	05-88-0205	Back Cover Screw	4
4	05-88-0210	Screw	9
5	05-88-1500	M6 x 1.0 LH Chuck Screw w/ locking patch	1
6	06-82-1020	Housing Screw	6
7	14-29-0210	Gearcase Assembly	1
8	14-50-0200	Motor Assembly	1
9	22-56-0990	Connector Block Assembly	1
10	23-66-2780	Switch	1
11	28-12-0075	Cover Plate	1
12	31-15-0655	Back Cover	1
13	31-50-3350	Housing Set	1
14	31-58-0075	Clutch Spring Nut	1
15	40-50-0395	Torque Ring Detent Spring	2
16	40-50-0415	Clutch Spring	1

FIG.	PART NO.	DESCRIPTION OF PART	NO. REQ.
17	40-50-0425	Selector Detent Spring	2
18	42-76-0075	Torque Ring	1
19	42-76-0155	Application Selector	1
20	43-72-0460	Bit Holder	2
21	44-60-0175	Pins	8
22	44-66-1250	Motor Mount Plate	1
23	45-24-0120	Speed Selector	1
24	45-24-0125	Forward/Reverse Button	1
25	45-88-1805	Washer	1
26	45-88-1810	Thrust Washer	1
27	48-66-1575	Chuck	1
28	05-81-0535	Gearcase Mount Screw	4
29	05-81-0530	Motor Mount Screw	2
31	12-20-0822	Service Nameplate (not shown)	1
32	44-14-0300	Speed Selector Wire Link	1
	51-15-0405	Side Handle (not shown)	1

Service Notes

8

Do not attempt to remove flag terminals from rear of motor (8), unsolder motor leadwires from switch only.

8, 22

Install motor mount plate (22) onto motor (8) with .320 "U" notch opening positioned to the top of the motor.

29

Place one drop of Red TYPE 262 Loctite® or equivalent onto threads of two motor mount screws (29) if removed during service.

5

Place one drop of Blue TYPE 242 Loctite® or equivalent onto threads of reversing chuck screw (5).

1, 7, 25

Install washer (25) (.059) over top eight clutch balls (1) of gear case assembly (7).

25, 26

Install thrust washer (26) (.031) over washer (25) in the assembly.

Anytime negative and positive leadwires require removal from bottom switch prongs/tabs, install a new ¼" long piece of black heat shrink tubing over each of the soldered switch connector tab-leadwires.

14, 16

Open end of clutch spring nut (14) to face clutch spring (16) in assembly.

Lubrication Instructions

Type "Z" (49-08-7655)

1. Apply a thin coat of grease to lobe of torque ring detent springs (15) prior to installing cover plate (11) into internal detents of torque ring (18).
2. Apply a thin coat of grease to lobe of selector detent springs (17) prior to installing application selector (19) onto gearcase assembly (7).
3. Apply a thin coat of grease to planetary gears in gearcase assembly (7) if dry.

WIRING INSTRUCTIONS

NOTE:

Proper polarity in the terminal block requires leads to be crossed, as illustrated.

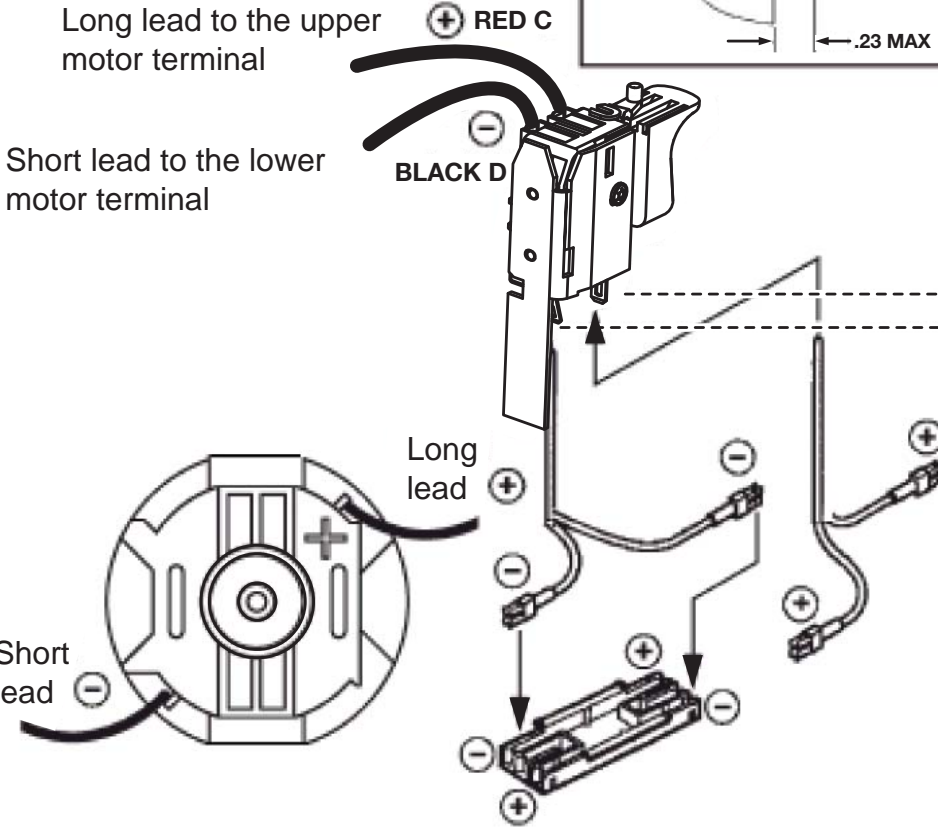
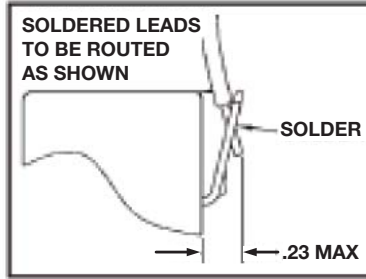

WARNING!

Switch polarity sensitive if wired incorrectly with the connector block assembly (9).
The switch will be damaged and destroyed.

WIRING SPECIFICATIONS				
Wire No.	Wire Color	Origin of Gauge	Length	Terminals, Connectors and 1 or 2 End Wire Preparation
A	Black	23-94-0135	-----	Leadwire assembly set, Black and Red leads
B	Red		-----	
C	Red	◆	5"	Strip end .25 and solder to switch
D	Black		4"	Strip end .25 and solder to switch
BULK LEAD WIRE - BULLETIN 58-01-0003				

TERMINAL DESCRIPTION		
Code	Part No.	Qty.