



SERVICE PARTS LIST

BULLETIN NO.
54-24-2801

SPECIFY CATALOG NO. AND SERIAL NO. WHEN ORDERING PARTS		REVISED BULLETIN 54-24-2800	DATE Aug. 2013
28 VOLT 1/2" HAMMER-DRILL			
CATALOG NO.	0726-20	STARTING SERIAL NO.	C26B
		WIRING INSTRUCTION SEE PAGE 2 and 3	

EXAMPLE:

00	0
----	---

 Component Parts (Small #) Are Included
 When Ordering The Assembly (Large #).

FIG.	PART NO.	DESCRIPTION OF PART	NO. REQ.
1	05-88-1503	5/16" Chuck Screw LH with Locking Patch	(1)
2	42-66-0757	1/2" Keyless Chuck	(1)
3	06-82-2025	M3.5 Handle Screw T-10	(7)
4	18-01-3025	Service Field	(1)
5	16-01-3061	Service Armature Assembly	(1)
★ 6	22-22-0751	Brush Card	(1)
7	45-24-0675	High / Low Shifter	(1)
8	42-42-0800	Forward / Reverse Button	(1)
9	-----	Switch	(1)
10	-----	Terminal Block Cover	(1)

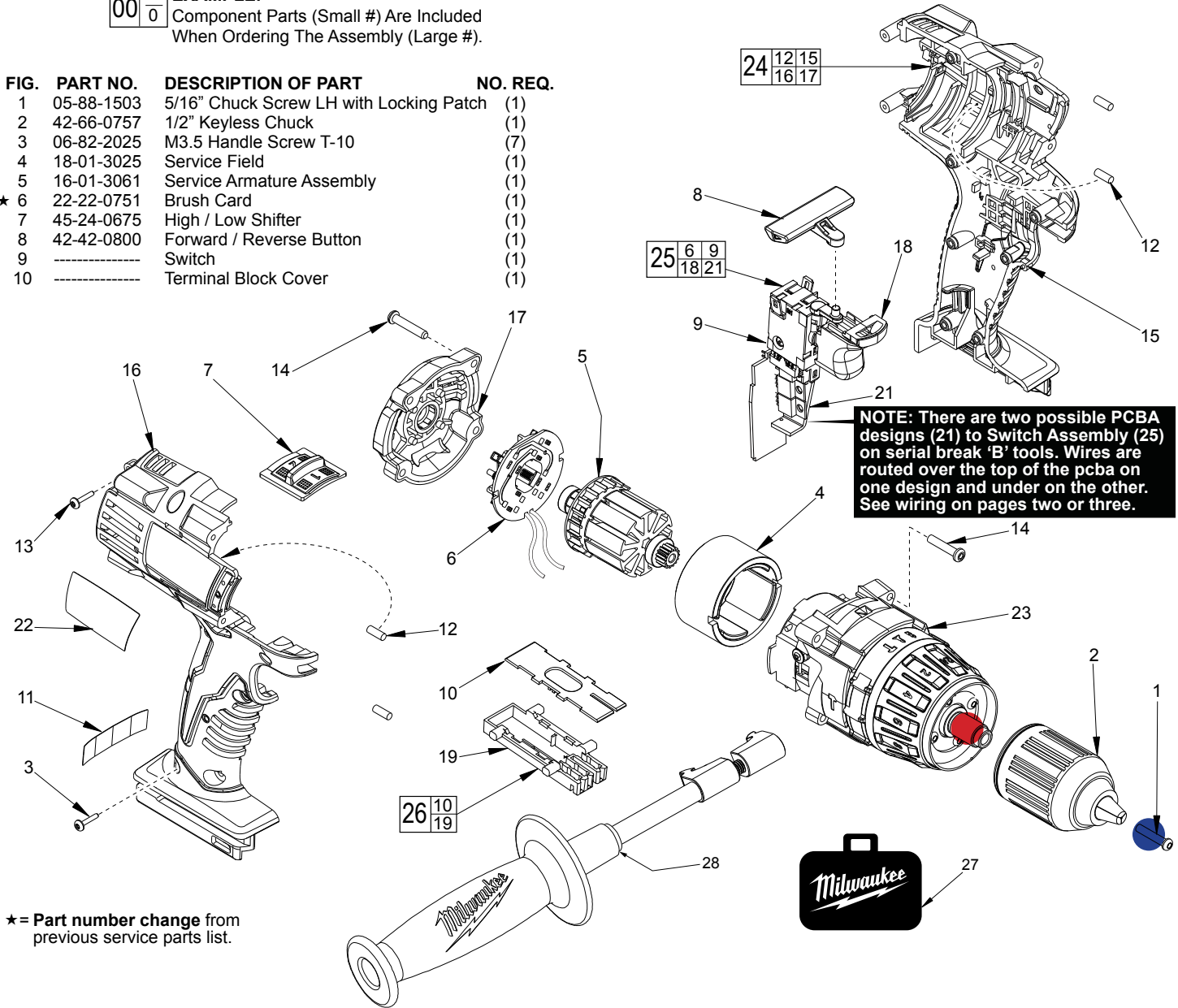

★ = Part number change from previous service parts list.

FIG.	PART NO.	DESCRIPTION OF PART	NO. REQ.
11	10-20-2760	Warning Label	(1)
12	45-30-0255	Rubber Slug	(4)
13	06-82-6350	M3 x 16mm Handle Screw T-10	(2)
14	05-88-1710	M3.5 x 22mm End Cap/Gearcase Scr T-10	(8)
15	-----	Left Handle	(1)
16	-----	Right Handle	(1)
17	42-52-0390	End Cap	(1)
18	-----	LED Assembly	(1)
19	-----	Terminal Block	(1)
21	-----	PCB Assembly	(1)
22	12-20-2811	Service Nameplate Kit	(1)
23	14-29-0402	Service Gearcase Assembly	(1)
24	31-44-2480	Service Housing Kit	(1)
★ 25	23-66-1336	Switch / Brush Card Assembly	(1)
26	22-56-1185	Terminal Block Assembly	(1)
27	42-55-1050	Carrying Case	(1)
28	42-62-0526	Side Handle Assembly	(1)

● = Apply Red Loctite® thread locking sealant or the equivalent to the threads of the gearcase spindle (23) before securing chuck to that spindle. Torque to 550-600in/lbs (45-50ft/lbs).

● = Apply Blue Loctite® thread locking sealant or the equivalent to the threads of the chuck screw (1) before securing chuck to the gearcase spindle. Torque to 340-350in/lbs (7-8ft/lbs).