



SERVICE PARTS LIST

BULLETIN NO.
54-06-0866

SPECIFY CATALOG NO. AND SERIAL NO. WHEN ORDERING PARTS		REVISED BULLETIN	DATE
1/2" KEYLESS CHUCK HOLE-SHOOTER		54-06-0865	Nov. '94
CATALOG NO. 0239-1	STARTING SERIAL NO. 756C	WIRING INSTRUCTION 58-01-0032	

EXAMPLE:
Component Parts (Small #)
Are Included When Ordering
The Assembly (Large #).

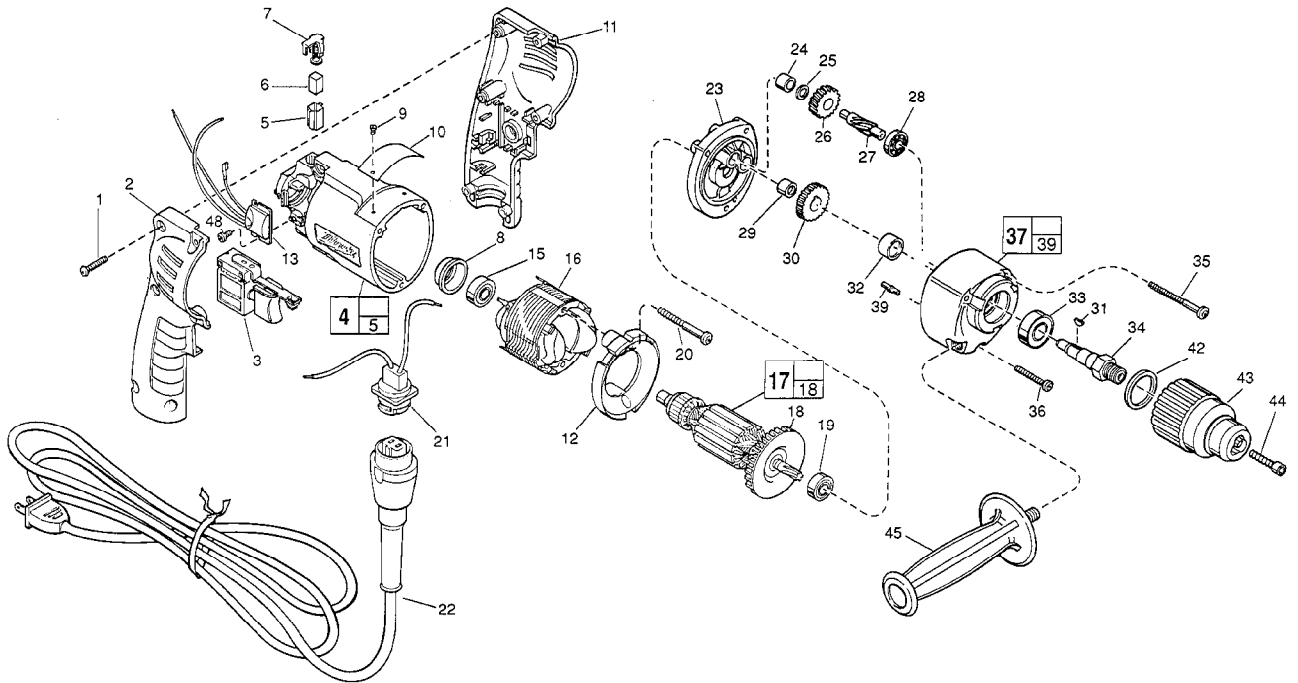

FIG.	PART NO.	DESCRIPTION OF PART	NO. REQ.
1	06-82-7284	8-16 x 3/4" Pan Hd. Slit. T-20	(6)
2	31-44-1845	Right Handle Half	(1)
3	23-66-2145	Speed Control Switch	(1)
★ 4	14-38-0591	Motor Housing Assembly	(1)
5	22-20-0830	Brush Tube	(2)
6	22-16-0275	Carbon Brush	(2)
7	23-52-1560	Brush Spring Assembly	(2)
8	22-72-0100	Bearing Cup	(1)
★ 9	06-72-1720	Nameplate Rivet	(2)
10	12-99-0860	Service Nameplate	(1)
11	31-44-1840	Left Handle Half	(1)
12	42-14-0380	Baffle	(1)
★ 13	14-20-0750	Remote Electronic Assembly	(1)
15	02-04-0645	Ball Bearing	(1)
16	18-11-0150	120 Volt Field	(1)
17	16-10-0680	120 Volt Armature	(1)
18	22-84-0880	Fan Assembly	(1)
19	02-04-0847	Ball Bearing	(1)
20	06-82-7203	7-18 x 2-1/8" Pan Hd. Slit. Plast. T-20	(2)
21	22-56-0665	Blade Housing Assembly	(1)
22	48-76-5010	Cord Set	(1)
23	28-28-1970	Diaphragm	(1)
24	02-50-1210	Needle Bearing	(1)
25	45-88-7301	Heat Treat Washer	(1)
26	32-40-2010	Intermediate Gear	(1)
27	36-66-4500	Intermediate Pinion Shaft	(1)
28	02-04-0640	Ball Bearing	(1)
29	02-50-1611	Needle Bearing	(1)
30	32-75-3320	Spindle Gear	(1)
31	06-42-1200	Woodruff Key	(1)
32	45-36-1100	Spindle Spacer	(1)
33	02-04-1229	Ball Bearing	(1)

FIG.	PART NO.	DESCRIPTION OF PART	NO. REQ.
34	38-50-5740	Spindle	(1)
35	06-82-7440	7-18 x 2-1/2" Pan Hd. Slit. Plast. T-20	(2)
36	06-82-7344	7-18 x 1-1/2" Pan Hd. Slit. Plast. T-20	(1)
37	14-30-0520	Gear Case Assembly	(1)
39	06-65-0825	Groove Pin	(1)
42	34-80-2300	Retaining Ring	(1)
43	48-66-2020	1/2" Keyless Chuck	(1)
44	06-75-3150	1/4-20 x 1" L.H. Thrd. Skt. Hd. Screw	(1)
45	43-62-0875	Side Handle	(1)
48	06-82-7212	4-20 x 1/4" Pan Hd. Plast. T-10	(1)

FIG. LUBRICATION
37 1-1/2 Oz. Type "E" Grease, 49-08-4122. Place Grease Near Intermediate Shaft Ball Bearing In Gear Case.

FIG. NOTES
1 Torque to 18-28 In./Lbs.
20, 35, 36 Torque to 15-20 In./Lbs.
48 Torque to 3-5 In./Lbs.
34 Apply Blue Loctite To Internal Threads Prior To Chuck Assembly
43 Hand Tighten Milwaukee Keyless Chuck Onto Spindle. Insert And Hand Tighten Chuck Retaining Screw. Insert Service Fixture 61-30-0155 Into The Chuck And Hand Tighten The Jaws Onto The Fixture. Place Fwd. / Rev. Switch In The Forward Position And Ratchet Chuck For 4 Seconds. Tighten Chuck Retaining Screw To Secure Chuck To Spindle (150 In.-Lbs.)
8 Place in motor housing before inserting armature.
24,29 Press flush to casting surface.
29 Press only on end with manufacturer ID.
15,19 Seal towards armature.
33 Seal towards retaining ring.

MILWAUKEE ELECTRIC TOOL CORPORATION
13135 W. LISBON RD., BROOKFIELD, WI 53005