



# SERVICE PARTS LIST

**BULLETIN NO.**  
**54-06-0859**

SPECIFY CATALOG NO. AND SERIAL NO. WHEN ORDERING PARTS		REVISED BULLETIN	DATE
<b>1/2" KEYLESS CHUCK MAGNUM DRILL</b>		54-06-0858	May '96
CATALOG NO. <b>0235-1</b>	STARTING SERIAL NO. <b>755A</b>	WIRING INSTRUCTION <b>58-01-1600</b>	

**EXAMPLE:**  
Component Parts (Small #)  
Are Included When Ordering  
The Assembly (Large #).

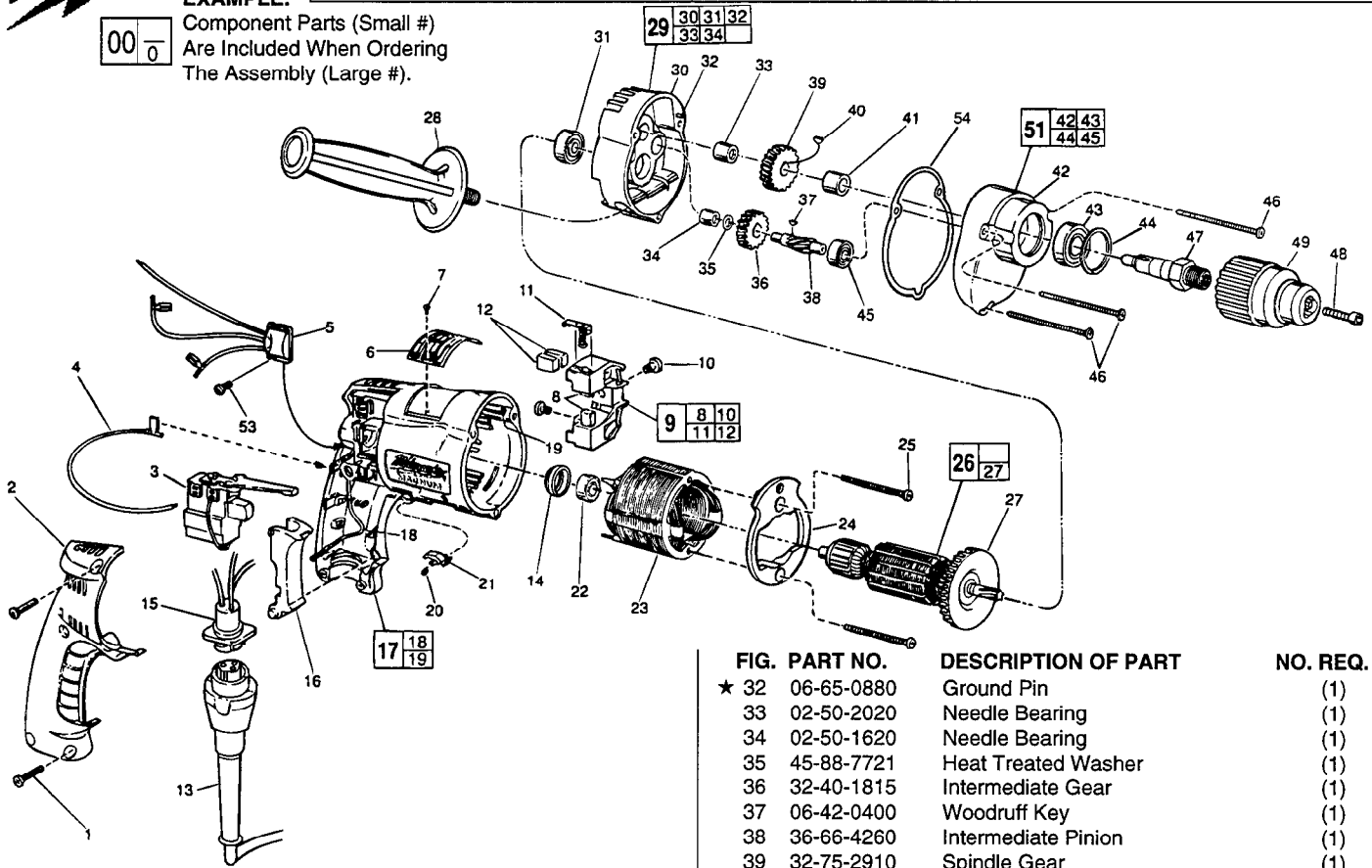

FIG.	PART NO.	DESCRIPTION OF PART	NO. REQ.
1	06-82-7266	7-18x11/16" Pan Hd. Plastite T-20	(5)
2	31-15-0402	Handle Cover	(1)
3	23-66-1665	Trigger Speed Control Switch	(1)
4	23-94-6245	2-1/4" Lead Assembly	(1)
5	14-20-0765	Remote Electronic Assembly	(1)
6	12-99-0071	Nameplate Blank	(1)
7	06-72-1720	Nameplate Rivet	(2)
8	22-16-0275	Carbon Brush	(2)
9	22-22-0351	Brush Holder Assembly	(1)
10	31-75-0040	Brush Holder Screw	(2)
11	22-20-0345	Brush Spring Assembly	(2)
12	22-16-0275	Carbon Brush (Spares)	(2)
13	48-76-4008	Cord Set	(1)
14	22-72-0100	Bearing Cup	(1)
15	22-56-0630	Pin Housing Assembly	(1)
16	45-72-0080	Trigger	(1)
17	14-38-0540	Motor Housing Assembly	(1)
18	23-94-9960	Ground Wire Assembly	(1)
19	44-60-1290	Grounding Pin	(1)
20	40-50-0085	Lock Button Spring	(1)
21	42-42-0460	Lock Button	(1)
22	02-04-0645	Ball Bearing	(1)
23	18-11-0075	120 Volt Field	(1)
24	42-14-0390	Baffle	(1)
25	06-82-7398	7-18x2-1/16" Pan Hd. Plastite T-20	(2)
26	16-10-0800	120 Volt Armature Assembly	(1)
27	22-84-0880	Fan	(1)
28	43-62-0885	Side Handle	(1)
★ 29	14-13-0497	Diaphragm Assembly	(1)
30	-----	Diaphragm	(1)
31	02-04-0847	Ball Bearing	(1)

FIG.	PART NO.	DESCRIPTION OF PART	NO. REQ.
★ 32	06-65-0880	Ground Pin	(1)
33	02-50-2020	Needle Bearing	(1)
34	02-50-1620	Needle Bearing	(1)
35	45-88-7721	Heat Treated Washer	(1)
36	32-40-1815	Intermediate Gear	(1)
37	06-42-0400	Woodruff Key	(1)
38	36-66-4260	Intermediate Pinion	(1)
39	32-75-2910	Spindle Gear	(1)
40	06-42-1200	Woodruff Key	(1)
41	45-36-1100	Spacer	(1)
42	-----	Gear Case	(1)
43	02-04-1229	Ball Bearing	(1)
44	34-80-2300	Retaining Ring	(1)
45	02-04-0640	Ball Bearing	(1)
46	06-82-7411	7-18 x 2-3/16" Pan Hd. Plastite T-20	(3)
47	38-50-5250	Spindle - Double Reduction	(1)
48	06-75-3155	Chuck Screw	(1)
49	48-66-2020	Keyless Chuck	(1)
★ 51	14-30-0337	Gear Case Assembly	(1)
53	06-82-7212	4-20 x 1/4" Pan Hd. Plastite T-10	(1)
★ 54	43-44-0913	Gasket	(1)
	10-98-5986	Warning Label	(1)

**FIG. LUBRICATION**  
42 1.5 Oz. Type "E" Grease, 49-08-4122. Place Grease Near Intermediate Shaft Ball Bearing In Gear Case.

**FIG. NOTES**  
47,48,49 New Chuck Screw, No. 06-75-3155, Is Pretreated With Fastener Adhesive. When Replacing Chuck With *Existing Chuck Screw*: Apply Fastener Adhesive To Chuck Screw Threads And Internal Threads Of Spindle Prior to Chuck Assembly.  
49 Hand Tighten Milwaukee Keyless Chuck Onto Spindle. Insert And Hand Tighten Chuck Retaining Screw. Insert Service Fixture 61-30-0155 Into The Chuck And Hand Tighten The Jaws Onto The Fixture. Place Fwd./Rev. Switch In The Forward Position And Ratchet Chuck For 4 Seconds. Tighten Chuck Retaining Screw To Secure Chuck To Spindle (150 Lb./In.).

**MILWAUKEE ELECTRIC TOOL CORPORATION**  
13135 W. LISBON RD., BROOKFIELD, WI 53005