



SERVICE PARTS LIST

BULLETIN NO.
54-06-0155

SPECIFY CATALOG NO. AND SERIAL NO. WHEN ORDERING PARTS		REVISED BULLETIN	DATE
1/2" MAGNUM HOLE-SHOOTER		54-06-0154	Oct. '90
CATALOG NO. 0234-1	STARTING SERIAL NO. 532-690500	WIRING INSTRUCTION 58-01-0074	

00 0

EXAMPLE:
Component Parts (Small #)
Are Included When Ordering
The Assembly (Large #).

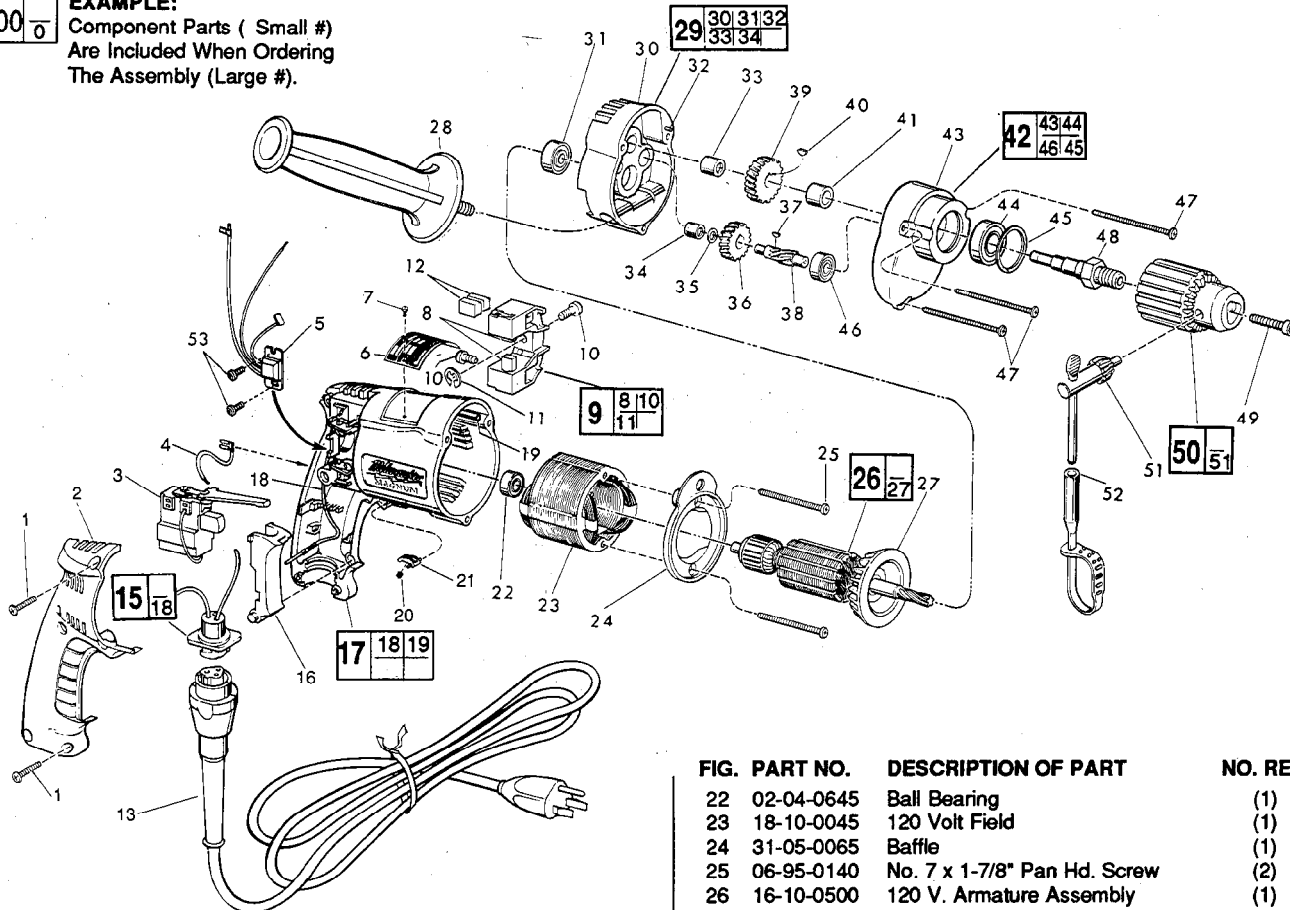

FIG.	PART NO.	DESCRIPTION OF PART	NO. REQ.
1	06-95-0185	7-1/8 x 11/16" Pan Hd. Plastite Screw	(5)
2	31-15-0101	Handle Cover	(1)
★ 3	23-66-1665	Trigger Speed Control Reversing Switch	(1)
4	23-94-9635	2-1/4 Lead Assembly	(1)
★ 5	14-20-0245	Remote Electronic Assembly	(1)
6	12-99-0071	Nameplate Bnk	(1)
7	06-85-0200	Nameplate Screw	(2)
8	22-16-0275	Carbon Brush	(2)
9	22-22-0350	Brush Holder Assembly	(1)
10	31-75-0011	Brush Holder Screw	(2)
11	34-60-0500	1/4" Ext. Retaining Ring	(1)
12	22-16-0275	Carbon Brush (Spares)	(2)
13	48-76-4008	Cord Set	(1)
15	22-56-0302	Pin Housing Assembly	(1)
16	45-72-0080	Trigger	(1)
★ 17	14-38-0356	Motor Housing Assembly	(1)
18	23-94-9686	Ground Wire Assembly	(1)
19	44-60-0570	Grounding Pin	(1)
20	40-50-0085	Lock Button Spring	(1)
21	42-42-0150	Lock Button	(1)

FIG.	PART NO.	DESCRIPTION OF PART	NO. REQ.
	22	02-04-0645 Ball Bearing	(1)
	23	18-10-0045 120 Volt Field	(1)
	24	31-05-0065 Baffle	(1)
	25	06-95-0140 No. 7 x 1-7/8" Pan Hd. Screw	(2)
	26	16-10-0500 120 V. Armature Assembly	(1)
	27	22-84-0650 Fan Assembly	(1)
	28	43-62-0885 Side Handle	(1)
	29	14-13-0350 Diaphragm Assembly	(1)
	30	28-28-1570 Diaphragm	(1)
	31	02-04-0847 Ball Bearing	(1)
	32	06-65-0825 1/8 x 1/2 Groove Pin No. 5	(1)
	33	02-50-2020 Needle Bearing	(1)
	34	02-50-1620 Needle Bearing	(1)
	35	45-88-7721 Heat Treated Washer	(1)
	36	32-40-1815 Intermediate Gear	(1)
	37	06-42-0400 Woodruff Key	(1)
	38	36-66-4260 Intermediate Pinion	(1)
	39	32-75-2910 Spindle Gear	(1)
	40	06-42-1200 Woodruff Key	(1)
	41	45-36-1100 Spacer	(1)
	42	14-30-0335 Gear Case Assembly	(1)
	43	28-14-1800 Gear Case	(1)
	44	02-04-1230 Ball Bearing	(1)
	45	34-80-2300 Retaining Ring	(1)
	46	02-04-0640 Ball Bearing	(1)
	47	06-95-0150 No. 7 x 2-3/16" Pan Hd. Screw	(3)
	48	38-50-5250 Spindle - Double Reduction	(1)
	49	06-75-3150 1/4-20 x 1" Skt. Hd. Screw-L.H.Thd.	(1)
	50	48-66-1360 1/2" Chuck	(1)
	51	48-66-3280 Chuck Key	(1)
	52	48-66-4040 Key Holder	(1)
★	53	06-82-7212 4-20x1/4" Pan Hd. Plastite Torx	(2)
★		10-98-5986 Warning Label	(1)

FIG. LUBRICATION
43 1-1/2 Oz. Type "E" Grease, No. 49-08-4121

MILWAUKEE ELECTRIC TOOL CORPORATION
13135 W. LISBON RD., BROOKFIELD, WI 53005