



SERVICE PARTS LIST

BUL. 54-06-2202

3/8" SPEED CONTROL DRILL

REVISED BUL. 54-06-2201 DATE Aug. '68

Catalog No. 0222

Starting Serial No. **404-7313**

WIRING INSTR. **58-01-0040**

Both Model and Serial No. must be furnished to obtain correct parts.

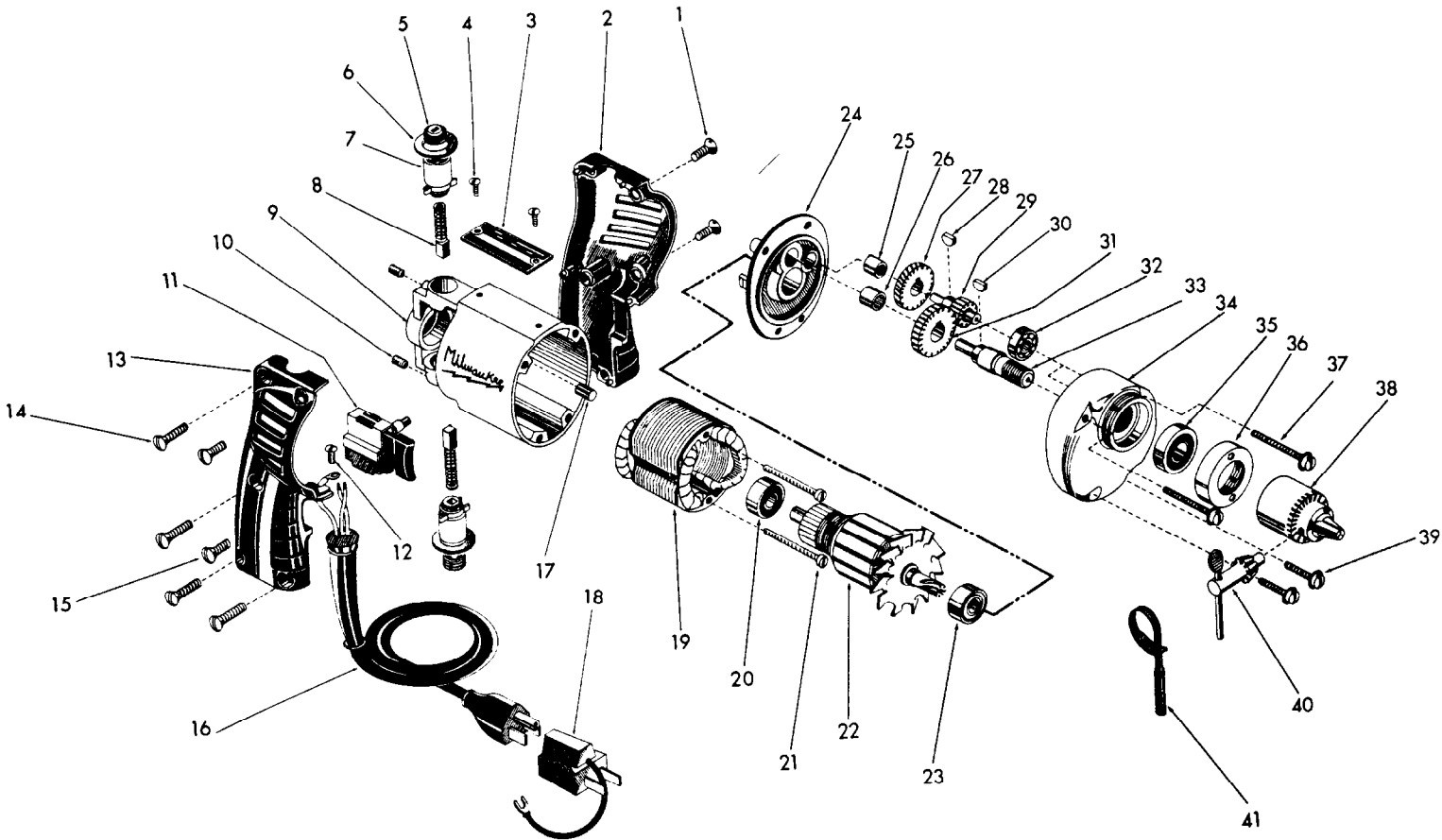

ILLUSTRATED PARTS

FIG.	PART NO.	DESCRIPTION OF PART	NO. REQ.	FIG.	PART NO.	DESCRIPTION OF PART	NO. REQ.
★1	06-81-0450	8-32x3/8 Pan Hd. Handle Mtg. Scr.	(2)	22	16-22-1241	Armature Assy.	
★2	31-44-0211	L.H. Handle Half		23	02-04-0740	Ball Bearing	
3	12-98-0600	Name Plate		24	28-28-0221	Diaphragm	
4	06-81-4300	3-48 x 3/16 Rd.Hd. Name Plate Scr.	(2)	25	02-50-1210	Needle Bearing	
5	23-44-0020	Brush Retaining Cap	(2)	26	02-50-1640	Needle Bearing	
6	23-86-0070	Insulating Washer	(2)	27	32-40-1121	Intermediate Gear	
7	22-22-0251	Brush Holder Assy.	(2)	28	06-42-0400	Woodruff Key	
8	22-18-0360	Carbon Brush Assy.	(2)	29	36-66-1551	Intermediate Pinion Shaft	
9	28-50-6091	Motor Housing (Incl. item 17)		30	06-42-0800	Woodruff Key	
10	06-83-0100	10-32x1/4 Hd'less Slotted Br.Hd.Scrs.	(2)	31	32-75-1361	Spindle Gear	
11	23-66-0600	Speed Control Switch		32	02-04-0640	Ball Bearing	
12	06-81-8625	6-32 x 1/4 (Bronze) Rd.Hd. Ground Scr.		33	38-50-1051	Spindle	
★13	31-44-0200	R. H. Handle Half		34	28-14-0361	Gear Case Assy.	
★14	06-81-0400	8-32x3/4 Pan Hd. Handle Mtg. Scr.	(4)	35	02-04-1020	Ball Bearing	
★15	06-81-0450	8-32x3/8 Pan Hd. Handle Mtg. Scr.	(2)	36	42-52-0060	Bearing Cap	
16	22-64-0450	Cord Set		37	06-81-6550	8-32 x 1 1/2 Fil.Hd.Sems Gear Case Scr.	(2)
17	45-30-0120	Ball Bearing Ret. Slug		38	48-66-0800	Chuck	
18	48-03-0010	Attachment Plug Adaptor (Except in Canada)		39	06-81-6300	8-32x7/8 Fil.Hd. Sems Gear Case Scr.	(2)
19	18-22-1121	Field		40	48-66-3080	Chuck Key	
20	02-04-0740	Ball Bearing		41	48-66-4040	Key Holder	
21	06-81-5950	6-32 x 1-7/8 Fil. Hd. Field Screws	(2)				