



SERVICE PARTS LIST

BUL. 54-06-1400

1/4" PISTOL DRILL

REVISED BUL. 6304-1 DATE FEB. '68

Catalog No. 0190

Starting Serial No. 304-1001

WIRING INSTR.

Both Model and Serial No. must be furnished to obtain correct parts.

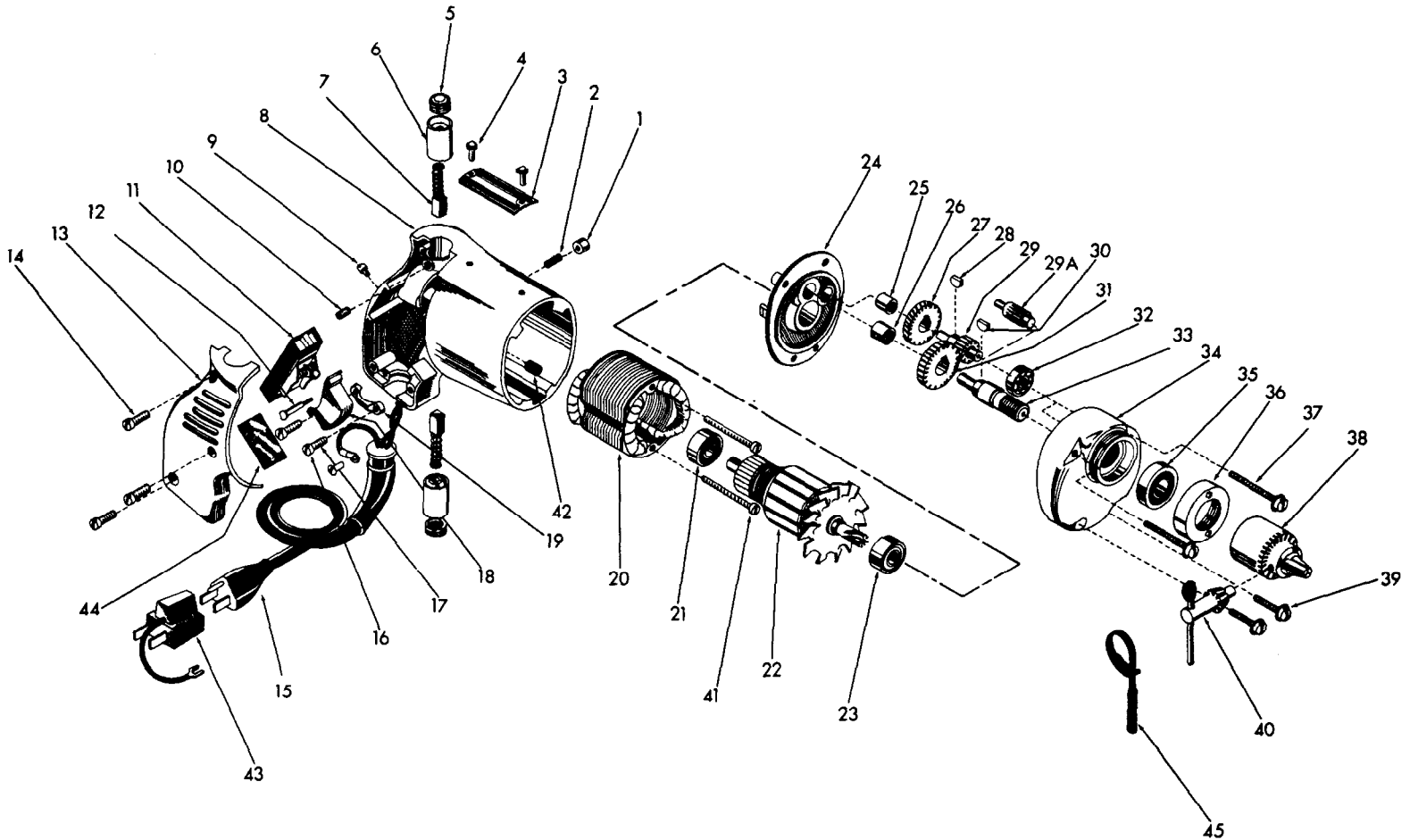

ILLUSTRATED PARTS

FIG.	PART NO.	DESCRIPTION OF PART	NO.REQ.	FIG.	PART NO.	DESCRIPTION OF PART	NO.REQ.
1	42-42-0061	Trigger Lock Button		23	02-04-0880	Armature Ball Bearing (Pinion End)	
2	40-50-1200	Trigger Lock Spring		24	28-28-0221	Diaphragm	
3	12-98-0600	Name Plate		25	02-50-1210	Needle Bearing	
4	06-81-4300	3-48x3/16 Rd. Hd. Name Plate Scr. (2)	(2)	26	02-50-1640	Needle Bearing	
5	23-44-0020	Brush Retaining Cap	(2)	27	32-40-1041	Intermediate Gear	
6	22-22-0050	Brush Holder Assy.	(2)	28	06-42-0400	No. 201 Woodruff Key	
7	22-18-0090	Carbon Brush Assy.	(2)	29	36-66-3701	Intermediate Pinion Shaft	
8	28-50-4447	Motor Housing		29A		Not Used On This Tool	
9	06-81-5800	6-32x5/16 Fil. Hd. Sems Switch Mtg. Scr.		30	06-42-0800	Woodruff Key	
10	06-83-0100	10-32x1/4 Hd'less Slotted Br. Hd. Scr. (2)	(2)	31	32-75-2381	Spindle Gear	
11	23-66-0280	Switch		32	02-04-0640	Intermediate Shaft Ball Bearing	
12	44-70-0071	Trigger Lock Shaft		33	38-50-1051	Spindle	
13	28-20-3002	Handle Cover		34	28-14-0361	Gear Case	
14	06-81-6150	8-32x1/2 Fil. Hd. Sems Handle Cover Sr. (3)	(3)	35	02-04-1020	Ball Bearing	
15	22-64-0170	Cord Set		36	45-52-0060	Bearing Cap	
16	06-81-6150	8-32x1/2 Fil. Hd. Sems Cord Clamp Scr. (2)	(2)	37	06-81-6550	8-32x1/2 Fil. Hd. Sems Gear Case Scr. (2)	(2)
17	06-81-8625	6-32x1/4 (Brass) Rd. Hd. Ground Scr.		38	48-66-0260	Chuck	
*18	31-92-0101	Switch Trigger		39	06-81-6300	8-32x7/8 Fil. Hd. Sems Gear Case Scr. (2)	(2)
19	28-17-0400	Cord Clamp		40	48-66-3200	Chuck Key	
20	18-22-1040	Field		41	06-81-5950	6-32 x 1-7/8 Fil. Hd. Field Screws (2)	(2)
21	02-04-0740	Armature Ball Bearing (Comm. End)		42	45-30-0060	Ball Bearing Ret. Slug	
22	16-22-1120	Armature Assy.		43	48-03-0010	Attachment Plug Adaptor	
				*44	23-16-0265	Switch Insulator	
				*45	48-66-4080	Key Holder	