



SERVICE PARTS LIST

BUL. 54-06-0600

1/4"

SPEED CONTROL DRILL

REVISED BUL
6403-1

DATE
FEB. '68

Catalog No. 0122

Starting
Serial No. 403-1001

WIRING INSTR.

Both Model and Serial No. must be furnished to obtain correct parts.

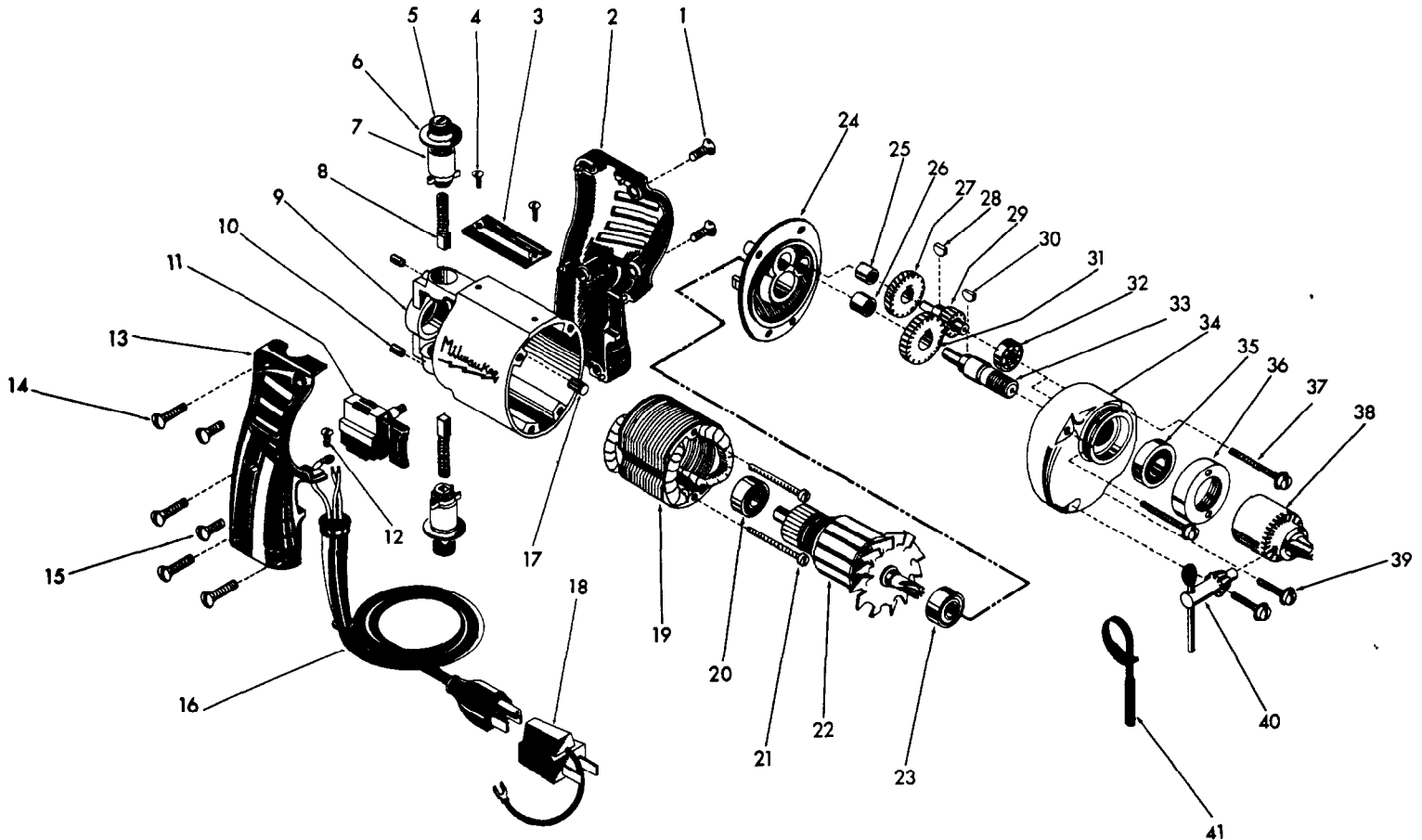

CORRECTS AND SUPERCEDES
SERVICE BULLETIN 6403-1
DATED 2/22/67

ILLUSTRATED PARTS

FIG.	PART NO.	DESCRIPTION OF PART	NO.REQ.	FIG.	PART NO.	DESCRIPTION OF PART	NO.REQ.
1	06-81-3600	8-32x3/8 Oval Hd.Handle Mtg. Scrs.	(2)	22	16-22-1120	Armature Assy.	
2	31-44-0111	L.H. Handle Half		*23	02-04-0880	Ball Bearing	
3	12-98-0600	Name Plate		24	28-28-0221	Diaphragm	
4	06-81-4300	3-48x3/16 Rd.Hd.Name Plate Screws	(2)	25	02-50-1210	Needle Bearing	
5	23-44-0020	Brush Retaining Cap	(2)	26	02-50-1640	Needle Bearing	
6	23-86-0070	Insulating Washer	(2)	27	32-40-1041	Intermediate Gear	
7	22-22-0251	Brush Holder Assy.	(2)	28	06-42-0400	Woodruff Key	
8	22-18-0360	Carbon Brush Assy.	(2)	29	36-66-1151	Intermediate Pinion Shaft	
9	28-50-6091	Motor Housing		30	06-42-0800	Woodruff Key	
10	06-83-0100	10-32x1/4 Hd'less Slotted Br.Hd. Scrs.	(2)	31	32-75-1181	Spindle Gear	
11	23-66-0600	Speed Control Switch		32	02-04-0640	Ball Bearing	
12	06-81-8625	6-32x1/4 (Bronze) Rd. Hd. Ground Scr.		33	38-50-1051	Spindle	
13	31-44-0100	R. H. Handle Half		34	28-14-0361	Gear Case Assy.	
14	06-81-3650	8-32x1/4 Oval Hd. Handle Mtg.Scrcs.	(4)	35	02-04-1020	Ball Bearing	
15	06-81-3600	8-32x3/8 Oval Hd. Handle Mtg.Scrcs.	(2)	36	42-52-0060	Bearing Cap	
16	22-64-0450	Cord Set		37	06-81-6550	8-32 x 1 1/2 Fil.Hd. Sems Gear Case Scrs.	(2)
17	45-30-0120	Ball Bearing Ret. Slug		38	48-66-0260	Chuck	
18	48-03-0010	Attachment Plug Adaptor		39	06-81-6300	8-32 x 7/8 Fil.Hd. Sems Gear Case Scrs.	(2)
19	18-22-1030	Field		40	48-66-3200	Chuck Key	
20	02-04-0740	Ball Bearing		41	48-66-4080	Key Holder	
21	06-81-5950	6-32 x 1-7/8 Fil.Hd. Field Screws	(2)				