



# SERVICE PARTS LIST

**BUL.54-06-0501**

## 1/4" PISTOL DRILL

REVISED BUL 6377-2      DATE Feb. '68

**Catalog No. 0121**

Starting Serial No. **377-2331**

WIRING INSTR. **58-01-0050**

Both Model and Serial No. must be furnished to obtain correct parts.

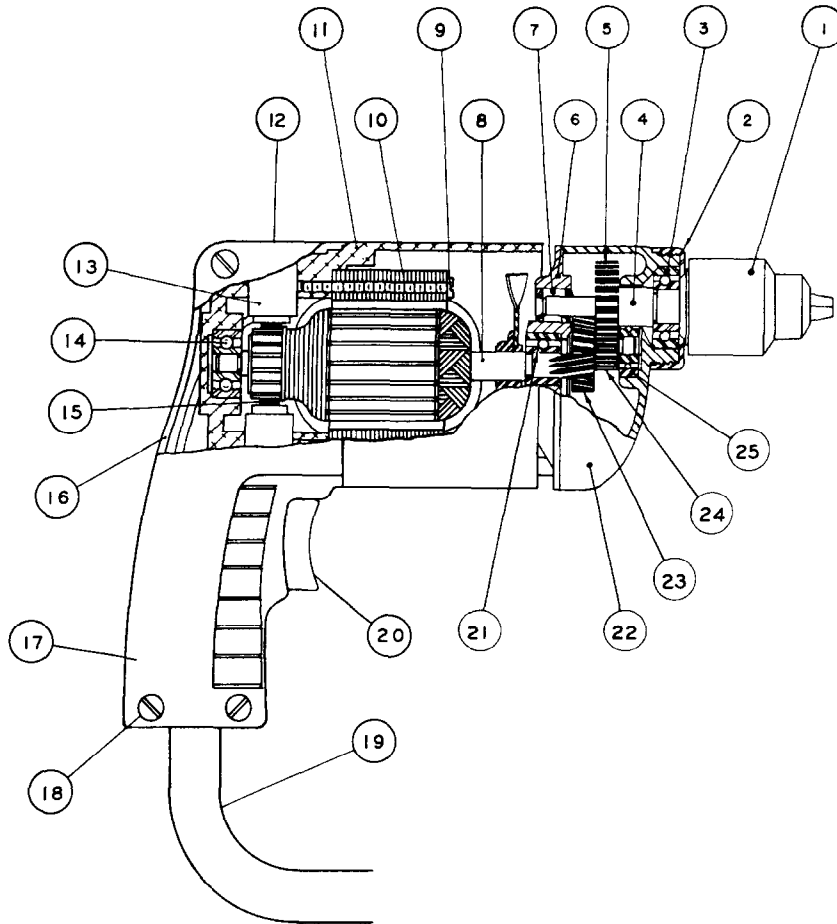

### ILLUSTRATED PARTS

FIG.	PART NO.	DESCRIPTION OF PART	NO.REQ.	FIG.	PART NO.	DESCRIPTION OF PART	NO.REQ.
1	48-66-0260	Chuck		13	22-22-0251	Brush Holder Assy.	(2)
2	42-52-0060	Bearing Cap		14	02-04-0740	Ball Bearing	
3	02-04-1020	Ball Bearing		15	22-18-0360	Carbon Brush Assy.	(2)
4	38-50-1051	Spindle		16	31-44-0111	Left Hand Handle Half	
5	32-75-1181	Spindle Gear		17	31-44-0100	Right Hand Handle Half	
6	28-28-0221	Diaphragm		18	06-81-3650	8-32 x 3/4" Oval Hd. Handle Screw	(4)
7	02-50-1640	Needle Bearing		19	22-64-0450	Cord Set	
★ 8	16-22-1231	Armature		20	23-66-0510	Switch	
9	06-81-5950	6-32 x 1-7/8" Fil. Hd. Field Screw	(2)	21	02-04-0880	Ball Bearing (Pinion End)	
★ 10	18-22-1121	Field		22	28-14-0361	Gear Case	
11	28-50-6091	Motor Housing		23	32-40-1041	Intermediate Gear	
12	23-44-0020	Brush Retaining Cap	(2)	24	36-66-1151	Intermediate Pinion Shaft	
				25	02-04-0640	Ball Bearing	

### MISCELLANEOUS PARTS NOT SHOWN

PART NO.	DESCRIPTION OF PART	NO.REQ.	PART NO.	DESCRIPTION OF PART	NO.REQ.
06-83-0100	10-32 x 1/4" Hd. Less Slotted Brush Holder Screw	(2)	06-42-0800	Woodruff Key	
02-50-1210	Needle Bearing		48-66-3200	Chuck Key	
06-42-0400	Woodruff Key		45-30-0120	Ball Bearing Retaining Slug	
48-03-0010	Attachment Plug Adaptor		06-83-0100	10-32 x 1/4" Brush Holder Set Screw	(2)
06-81-8625	6-32 x 1/4" Rd. Hd. Sems Ground Screw		06-83-4300	3-48 x 3/16" Rd. Hd. Name Plate Screw	(2)
06-81-6550	8-32 x 1 1/2" Fil. Hd. Sems Gear Case Screw	(2)	06-81-3600	8-32 x 3/8" Oval Hd. Handle Mtg. Screw	(4)
12-98-0600	Name Plate		48-66-4080	Key Holder	(2)
06-81-6300	8-32 x 7/8 Fil. Hd. Sems Gear Case Scrs.	(2)			