



SERVICE PARTS LIST

BULLETIN NO.
54-06-0360

SPECIFY CATALOG NO. AND SERIAL NO. WHEN ORDERING PARTS		REVISED BULLETIN 54-06-0359	DATE Dec. '99
1/4" T.S.C. REV. HOLE-SHOOTER		WIRING INSTRUCTION 58-01-1591	
CATALOG NO. 0102-1	STARTING SERIAL NO. 428C / 428D		

EXAMPLE:



Component Parts (Small #)
Are Included When Ordering
The Assembly (Large #).

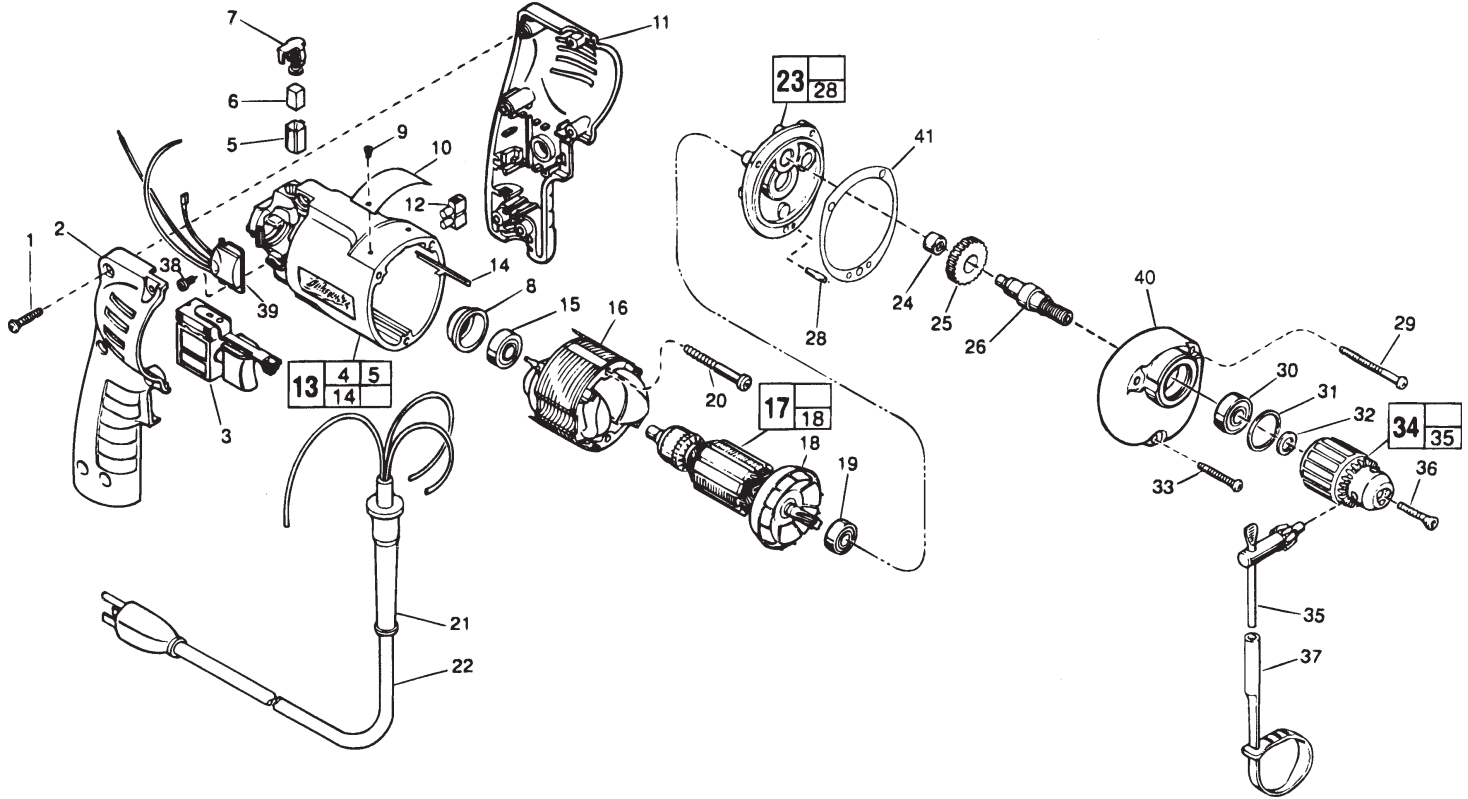

FIG.	PART NO.	DESCRIPTION OF PART	NO. REQ.
	1	06-82-7284 8-16 x 3/4" Pan Hd. Slit. Plast. T-20	(6)
	2	31-44-1745 Right Handle Half	(1)
	3	23-66-2145 Speed Control Switch	(1)
	4	23-94-6225 Ground Wire Assembly (Not Shown)	(1)
	5	22-20-0830 Brush Tube	(2)
	6	22-16-0275 Carbon Brush	(2)
	7	23-52-1560 Brush Spring Assembly	(2)
	8	22-72-0100 Bearing Cup	(1)
	9	06-72-1720 Nameplate Rivet	(2)
	10	12-99-0850 Service Nameplate	(1)
	11	31-44-1740 Left Handle Half	(1)
	12	22-56-0456 Terminal Block	(1)
	13	14-38-0601 Motor Housing Assembly	(1)
	14	44-60-0530 Ground Pin	(1)
	15	02-04-0645 Ball Bearing	(1)
	16	18-11-0060 120 Volt Field	(1)
	17	16-10-0440 120 Volt Armature	(1)
	18	22-84-0760 Fan Assembly	(1)
★	19	02-04-0851 Ball Bearing	(1)
	20	06-82-7393 7-18 x 2" Pan Hd. Slit. Plast. T-20	(2)
	21	44-76-0210 Cord Protector	(1)
	22	22-64-1120 Cord Set	(1)
★	23	14-13-0525 Diaphragm Assembly	(1)
	24	02-50-1620 Needle Bearing	(1)
	25	32-75-3260 Spindle Gear	(1)
	26	38-50-5670 Spindle	(1)
★	28	06-65-0880 Ground Pin	(1)
	29	06-82-7344 7-18 x 1-1/2" Pan Hd. Slit. Plast. T-20	(2)

FIG.	PART NO.	DESCRIPTION OF PART	NO. REQ.
	30	02-04-1020 Ball Bearing	(1)
	31	34-80-1400 Retaining Ring	(1)
	32	45-88-7940 Chuck Washer	(1)
	33	06-82-7308 7-18 x 1-1/8" Pan Hd. Slit. Plast. T-20	(1)
	34	48-66-0070 1/4" Chuck	(1)
	35	48-66-3200 Chuck Key	(1)
	36	45-04-0750 Chuck Screw-L.H. Thread	(1)
	37	48-66-4080 Key Holder	(1)
	38	06-82-7212 4-20 x 1/4" Pan Hd. Plastite T-10	(1)
	39	14-20-0750 Remote Electronic Assembly	(1)
★	40	28-14-1835 Gear Case	(1)
★	41	43-44-0925 Gasket	(1)

FIG. LUBRICATION
40 1-1/8 Oz. Type "E" Grease, No. 49-08-4122.
Place In Center Of Gear Case.

FIG. NOTES
1 Torque to 18-28 In./Lbs.
20, 29, 33 Torque to 15-20 In./Lbs.
36 Torque to 30-50 In./Lbs.
38 Torque to 3-5 In./Lbs.
8 Place in motor housing before inserting armature.
24 Press flush to casting surface.
15, 19 Seal towards armature.
30 Seal towards chuck.